

Application Notes and Protocols for Sunitinib (SU11248) in Cell Culture

Author: BenchChem Technical Support Team. **Date:** December 2025

Compound of Interest

Compound Name: SUN C5174

Cat. No.: B1682718

[Get Quote](#)

For Researchers, Scientists, and Drug Development Professionals

Introduction

Sunitinib, also known as SU11248, is a potent, orally bioavailable, multi-targeted receptor tyrosine kinase (RTK) inhibitor. It plays a crucial role in cancer therapy by targeting several RTKs implicated in tumor growth, angiogenesis, and metastatic progression. This document provides detailed application notes and protocols for the use of Sunitinib in cell culture experiments, with a focus on determining its effective concentration and understanding its mechanism of action.

Mechanism of Action

Sunitinib exerts its anti-tumor and anti-angiogenic effects by inhibiting multiple RTKs. Its primary targets include Platelet-Derived Growth Factor Receptors (PDGFR α and PDGFR β) and Vascular Endothelial Growth Factor Receptors (VEGFR1, VEGFR2, and VEGFR3).^{[1][2][3][4]} Additionally, it is a potent inhibitor of KIT (stem cell factor receptor), FMS-like tyrosine kinase-3 (FLT3), and the rearranged during transfection (RET) proto-oncogene.^{[1][4][5]}

By binding to the ATP-binding site of these kinases, Sunitinib blocks their phosphorylation and subsequent activation.^[2] This inhibition disrupts downstream signaling pathways crucial for cell proliferation and survival, such as the RAS/MAPK and PI3K/AKT pathways.^{[1][6]} The blockade of VEGFR and PDGFR signaling in endothelial cells and pericytes, respectively, leads to the inhibition of angiogenesis, the formation of new blood vessels that tumors need to grow.^{[2][5][7]}

Signaling Pathway Diagram

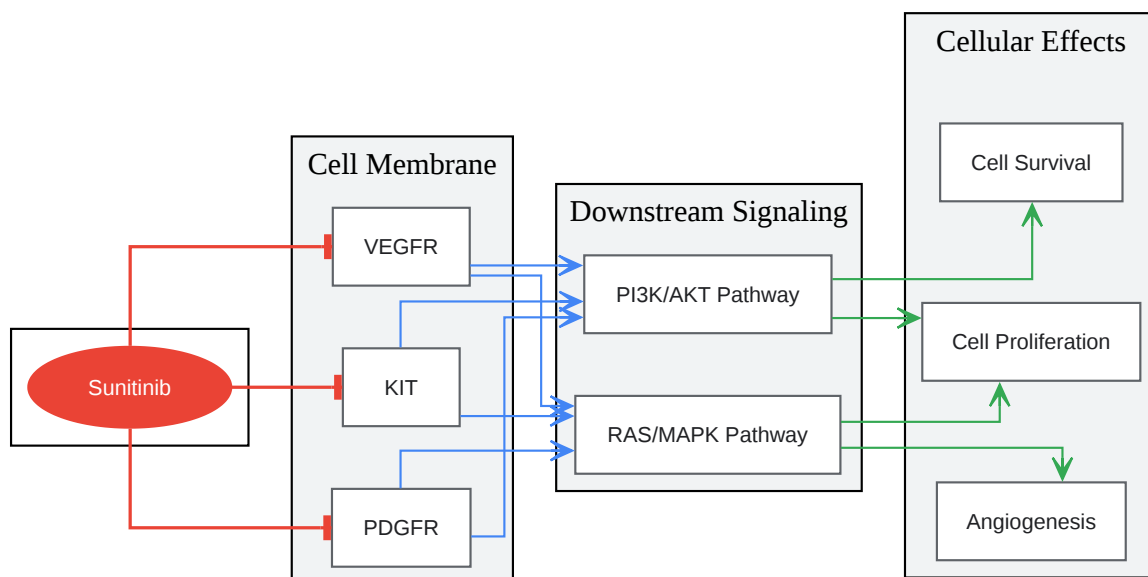

[Click to download full resolution via product page](#)

Caption: Sunitinib inhibits multiple receptor tyrosine kinases, blocking downstream signaling pathways and cellular processes.

Recommended Concentrations for Cell Culture

The effective concentration of Sunitinib can vary significantly depending on the cell line and the specific biological question being addressed. It is recommended to perform a dose-response curve to determine the optimal concentration for your experimental system. The half-maximal inhibitory concentration (IC₅₀) is a common metric used to quantify the potency of a compound.

Summary of Sunitinib IC₅₀ Values in Various Cell Lines

Cell Line	Cancer Type	IC50 (μM)	Notes
HUVEC	Endothelial	0.04	Inhibition of VEGF-induced proliferation. [8] [9]
NIH-3T3 (PDGFRβ)	Fibroblast	0.039	Inhibition of PDGF-induced proliferation. [8] [9]
NIH-3T3 (PDGFRα)	Fibroblast	0.069	Inhibition of PDGF-induced proliferation. [8] [9]
MV4;11	Acute Myeloid Leukemia	0.008	Inhibition of proliferation. [8] [9]
OC1-AML5	Acute Myeloid Leukemia	0.014	Inhibition of proliferation. [8] [9]
U87	Glioblastoma	~3.0 - 8.5	Median IC50 of 5.4 μM across several GBM cell lines. [10]
U251	Glioblastoma	~3.0 - 8.5	Median IC50 of 5.4 μM across several GBM cell lines. [10]
T98G	Glioblastoma	~3.0 - 8.5	Median IC50 of 5.4 μM across several GBM cell lines. [10]
U138	Glioblastoma	~3.0 - 8.5	Median IC50 of 5.4 μM across several GBM cell lines. [10]
Caki-1	Renal Cell Carcinoma	2.2	[11]
A549	Non-Small Cell Lung Cancer	3.6 ± 0.41	[12]

Note: IC50 values can be influenced by experimental conditions such as cell density, serum concentration, and duration of treatment.

Experimental Protocols

Protocol 1: Determination of IC50 using a Cell Viability Assay (e.g., MTT or CellTiter-Glo®)

This protocol outlines the steps to determine the concentration of Sunitinib that inhibits cell viability by 50%.

Materials:

- Cancer cell line of interest
- Complete cell culture medium (e.g., DMEM or RPMI-1640 with 10% FBS)
- Sunitinib malate
- Dimethyl sulfoxide (DMSO) for stock solution preparation
- 96-well cell culture plates
- Cell viability assay reagent (e.g., MTT or CellTiter-Glo®)
- Plate reader

Procedure:

- Cell Seeding:
 - Trypsinize and count cells.
 - Seed cells in a 96-well plate at a density of 5,000-10,000 cells per well in 100 μ L of complete medium.
 - Incubate overnight at 37°C in a humidified atmosphere with 5% CO₂ to allow for cell attachment.[\[12\]](#)

- Sunitinib Preparation and Treatment:
 - Prepare a stock solution of Sunitinib in DMSO (e.g., 10 mM).
 - Perform serial dilutions of the Sunitinib stock solution in complete culture medium to achieve the desired final concentrations (e.g., a range from 0.001 μ M to 100 μ M). Include a vehicle control (medium with the same concentration of DMSO as the highest Sunitinib concentration).
 - Remove the medium from the wells and add 100 μ L of the Sunitinib dilutions or vehicle control to the respective wells.
- Incubation:
 - Incubate the plate for 48-72 hours at 37°C and 5% CO₂. The incubation time may need to be optimized for your specific cell line.
- Cell Viability Measurement:
 - Follow the manufacturer's instructions for the chosen cell viability assay.
 - For an MTT assay, this typically involves adding the MTT reagent, incubating for a few hours, and then adding a solubilization solution before reading the absorbance.
 - For a CellTiter-Glo® assay, add the reagent directly to the wells and read the luminescence.
- Data Analysis:
 - Normalize the data to the vehicle-treated control wells (set to 100% viability).
 - Plot the percentage of cell viability against the logarithm of the Sunitinib concentration.
 - Use a non-linear regression analysis (e.g., sigmoidal dose-response curve) to calculate the IC₅₀ value.

Experimental Workflow Diagram

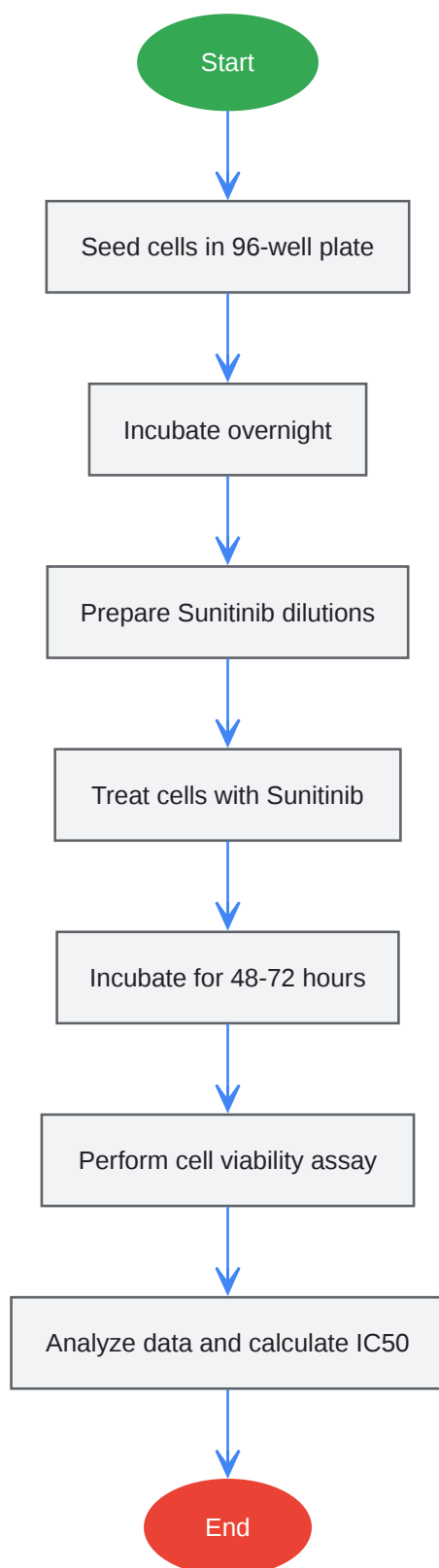

[Click to download full resolution via product page](#)

Caption: A general workflow for determining the IC₅₀ of Sunitinib in a cell culture experiment.

Concluding Remarks

Sunitinib is a powerful tool for in vitro studies of cancer cell biology and anti-angiogenic drug development. The protocols and data presented here provide a foundation for designing and executing experiments to investigate its effects. It is imperative for researchers to empirically determine the optimal conditions for their specific cell lines and experimental goals to ensure reproducible and meaningful results.

Need Custom Synthesis?

BenchChem offers custom synthesis for rare earth carbides and specific isotopic labeling.

Email: info@benchchem.com or [Request Quote Online](#).

References

- 1. researchgate.net [researchgate.net]
- 2. Sunitinib: a VEGF and PDGF receptor protein kinase and angiogenesis inhibitor - PubMed [pubmed.ncbi.nlm.nih.gov]
- 3. Sunitinib: a novel tyrosine kinase inhibitor. A brief review of its therapeutic potential in the treatment of renal carcinoma and gastrointestinal stromal tumors (GIST) - PMC [pmc.ncbi.nlm.nih.gov]
- 4. What is the mechanism of Sunitinib Malate? [synapse.patsnap.com]
- 5. Sunitinib: the antiangiogenic effects and beyond - PMC [pmc.ncbi.nlm.nih.gov]
- 6. aacrjournals.org [aacrjournals.org]
- 7. researchgate.net [researchgate.net]
- 8. selleckchem.com [selleckchem.com]
- 9. selleckchem.com [selleckchem.com]
- 10. aacrjournals.org [aacrjournals.org]
- 11. researchgate.net [researchgate.net]
- 12. benchchem.com [benchchem.com]
- To cite this document: BenchChem. [Application Notes and Protocols for Sunitinib (SU11248) in Cell Culture]. BenchChem, [2025]. [Online PDF]. Available at:

[<https://www.benchchem.com/product/b1682718#recommended-concentration-of-sun-c5174-for-cell-culture>]

Disclaimer & Data Validity:

The information provided in this document is for Research Use Only (RUO) and is strictly not intended for diagnostic or therapeutic procedures. While BenchChem strives to provide accurate protocols, we make no warranties, express or implied, regarding the fitness of this product for every specific experimental setup.

Technical Support: The protocols provided are for reference purposes. Unsure if this reagent suits your experiment? [[Contact our Ph.D. Support Team for a compatibility check](#)]

Need Industrial/Bulk Grade? [Request Custom Synthesis Quote](#)

BenchChem

Our mission is to be the trusted global source of essential and advanced chemicals, empowering scientists and researchers to drive progress in science and industry.

Contact

Address: 3281 E Guasti Rd
Ontario, CA 91761, United States
Phone: (601) 213-4426
Email: info@benchchem.com