

# Application Notes and Protocols for Sulfonamides in In Vitro Cell Culture

**Author:** BenchChem Technical Support Team. **Date:** December 2025

## Compound of Interest

Compound Name: Sulfabenz

Cat. No.: B111562

[Get Quote](#)

For Researchers, Scientists, and Drug Development Professionals

## Introduction

The sulfonamide functional group is a cornerstone in medicinal chemistry, with compounds bearing this moiety exhibiting a wide array of biological activities. While initially developed as antimicrobial agents, their therapeutic applications have expanded to include anti-inflammatory and anticancer effects. This document provides detailed application notes and protocols for the in vitro use of two such sulfonamides, **Sulfabenzamide** and Sulfasalazine, in cell culture settings. The user's query for "**Sulfabenz**" is addressed by providing information on these two distinct, yet structurally related, compounds. These notes are intended to guide researchers in exploring their cytotoxic, pro-apoptotic, and anti-proliferative properties.

## Section 1: Sulfabenzamide

**Sulfabenzamide** has been investigated for its antitumor effects, demonstrating a primary mechanism of action involving the induction of autophagy in cancer cells.

## Application Notes

**Mechanism of Action:** In vitro studies have shown that **Sulfabenzamide's** anti-proliferative effects are primarily mediated through the induction of autophagic cell death.[1][2] This process is initiated via the p53/DRAM signaling pathway.[1][2] Notably, in T-47D breast cancer cells, **Sulfabenzamide** treatment leads to the overexpression of key autophagy-related genes such

as ATG5, p53, and DRAM.[1] This is coupled with a downregulation of the AKT/mTOR survival pathway, further promoting autophagy. While an increase in caspase-3 activity has been observed, it does not lead to typical apoptotic DNA fragmentation, suggesting a non-apoptotic role for this enzyme in mediating autophagy. Studies in T-47D cells have indicated that **Sulfabenzamide** does not cause significant apoptosis or cell cycle arrest.

Cell Line Specificity: The effects of **Sulfabenzamide** have been documented in the T-47D breast cancer cell line. Further investigation into a broader range of cancer cell lines is warranted to determine the full spectrum of its activity.

## Quantitative Data

Compound	Cell Line	Effect	Concentration/IC50	Reference
Sulfabenzamide	T-47D	Inhibition of Proliferation	Not explicitly defined with an IC50 value in the provided search results.	
Sulfabenzamide	T-47D	Increased Caspase-3 Activity	Concentrations up to 10.8 mM tested.	

## Section 2: Sulfasalazine

Sulfasalazine, a drug traditionally used for inflammatory bowel disease, has demonstrated potent pro-apoptotic and anti-proliferative effects in various cancer cell models.

## Application Notes

Mechanism of Action: Sulfasalazine exerts its anticancer effects through multiple mechanisms. A primary mode of action is the induction of apoptosis via the mitochondrial pathway. This involves the downregulation of anti-apoptotic proteins Bcl-2 and Bcl-xl, leading to the activation of caspase-9 and caspase-3. The apoptotic induction by Sulfasalazine is independent of the Fas death receptor pathway.

Another key mechanism is the potent and specific inhibition of the nuclear factor kappa B (NF- $\kappa$ B) signaling pathway. Sulfasalazine directly inhibits I $\kappa$ B kinases (IKK- $\alpha$  and IKK- $\beta$ ), which prevents the phosphorylation and subsequent degradation of I $\kappa$ B $\alpha$ . This retains NF- $\kappa$ B in the cytoplasm, inhibiting the transcription of pro-inflammatory and pro-survival genes.

Sulfasalazine has also been shown to inhibit the cystine-glutamate antiporter (system Xc-), leading to depletion of intracellular glutathione and increased oxidative stress, which can contribute to cell death. Furthermore, it can induce cell cycle arrest, particularly by slowing S-phase progression.

**Cell Line Specificity:** The effects of Sulfasalazine have been observed in various cell lines, including T-lymphocytes, colon cancer cells (SW620), pancreatic cancer cells (MIA PaCa-2, PANC-1), and glioblastoma cell lines.

## Quantitative Data

Compound	Cell Line	Effect	IC50/ED50	Reference
Sulfasalazine	Murine T-lymphocyte (RBL5)	Inhibition of $\kappa$ B-dependent transcription	~0.625 mM	
Sulfasalazine	Murine T-lymphocyte (RBL5)	Induction of Apoptosis	~0.625 mM (ED50 after 24h)	
Sulfasalazine	Human Pancreatic Cancer (MIA PaCa-2, PANC-1)	Growth Inhibition	Not specified	
Sulfasalazine	Human Glioblastoma	Apoptosis Induction	Not specified	
Sulfadiazine	HepG2 (Liver Cancer)	Antiproliferative	245.69 $\pm$ 4.1 $\mu$ M	
Sulfadiazine	MCF7 (Breast Cancer)	Antiproliferative	215.68 $\pm$ 3.8 $\mu$ M	

Note: IC50 values for other sulfonamides are provided for comparative context.

## Experimental Protocols

### Protocol 1: Cell Viability Assessment using MTT Assay

This protocol is a colorimetric assay to measure cellular metabolic activity as an indicator of cell viability, proliferation, and cytotoxicity.

Materials:

- Cells of interest
- 96-well tissue culture plates
- Complete culture medium
- **Sulfabenzamide** or Sulfasalazine stock solution (dissolved in DMSO)
- MTT (3-(4,5-dimethylthiazol-2-yl)-2,5-diphenyltetrazolium bromide) solution (5 mg/mL in PBS)
- Solubilization solution (e.g., DMSO, or 10% SDS in 0.01 M HCl)
- Phosphate Buffered Saline (PBS)
- Microplate reader

Procedure:

- **Cell Seeding:** Seed cells into a 96-well plate at a density of 5,000-10,000 cells/well in 100  $\mu$ L of complete culture medium. Incubate for 24 hours at 37°C in a humidified 5% CO<sub>2</sub> incubator to allow for cell attachment.
- **Compound Treatment:** Prepare serial dilutions of **Sulfabenzamide** or Sulfasalazine in culture medium. Remove the existing medium from the wells and add 100  $\mu$ L of the compound-containing medium. Include a vehicle control (medium with the same concentration of DMSO as the highest drug concentration) and a no-treatment control.

- Incubation: Incubate the plate for the desired time period (e.g., 24, 48, or 72 hours).
- MTT Addition: After incubation, add 10  $\mu$ L of MTT solution to each well.
- Formazan Crystal Formation: Incubate the plate for 2-4 hours at 37°C, allowing viable cells to metabolize MTT into purple formazan crystals.
- Solubilization: Carefully remove the medium and add 100  $\mu$ L of solubilization solution to each well to dissolve the formazan crystals.
- Absorbance Measurement: Measure the absorbance at 570 nm using a microplate reader.
- Data Analysis: Calculate the percentage of cell viability relative to the vehicle control.

## Protocol 2: Apoptosis Detection by Annexin V/Propidium Iodide (PI) Staining and Flow Cytometry

This method distinguishes between viable, early apoptotic, late apoptotic, and necrotic cells.

Materials:

- Cells treated with Sulfasalazine
- Annexin V-FITC/PI Apoptosis Detection Kit
- 1X Binding Buffer
- Flow cytometer

Procedure:

- Cell Treatment: Culture cells and treat with the desired concentrations of Sulfasalazine for the appropriate duration.
- Cell Harvesting: Collect both adherent and floating cells. For adherent cells, gently trypsinize and combine with the supernatant.
- Washing: Wash the cells twice with cold PBS by centrifugation (e.g., 300 x g for 5 minutes).

- Resuspension: Resuspend the cell pellet in 1X Binding Buffer to a concentration of  $1 \times 10^6$  cells/mL.
- Staining: Transfer 100  $\mu$ L of the cell suspension to a flow cytometry tube. Add 5  $\mu$ L of Annexin V-FITC and 5  $\mu$ L of Propidium Iodide.
- Incubation: Gently vortex the cells and incubate for 15 minutes at room temperature in the dark.
- Analysis: Add 400  $\mu$ L of 1X Binding Buffer to each tube and analyze by flow cytometry within 1 hour.
  - Viable cells: Annexin V-negative and PI-negative.
  - Early apoptotic cells: Annexin V-positive and PI-negative.
  - Late apoptotic/necrotic cells: Annexin V-positive and PI-positive.

## Protocol 3: Cell Cycle Analysis by Propidium Iodide (PI) Staining and Flow Cytometry

This protocol allows for the analysis of cell cycle distribution (G0/G1, S, G2/M phases).

Materials:

- Cells treated with Sulfasalazine
- Cold 70% ethanol
- PBS
- PI/RNase staining buffer
- Flow cytometer

Procedure:

- Cell Treatment and Harvesting: Treat cells with Sulfasalazine as described previously and harvest.
- Fixation: Resuspend the cell pellet in 1 mL of cold PBS. While gently vortexing, add 3 mL of cold 70% ethanol dropwise to fix the cells. Incubate at -20°C for at least 2 hours.
- Washing: Centrifuge the fixed cells, discard the ethanol, and wash the cell pellet with PBS.
- Staining: Resuspend the cell pellet in 500 µL of PI/RNase staining buffer.
- Incubation: Incubate for 30 minutes at room temperature in the dark.
- Analysis: Analyze the samples using a flow cytometer. The DNA content will be proportional to the PI fluorescence intensity, allowing for the quantification of cells in different phases of the cell cycle.

## Visualizations

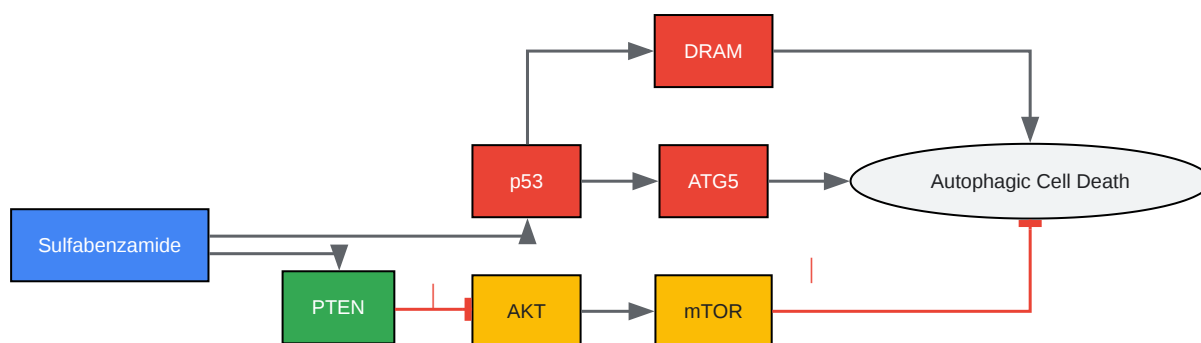

[Click to download full resolution via product page](#)

Caption: **Sulfabenzamide**-induced autophagy signaling pathway.

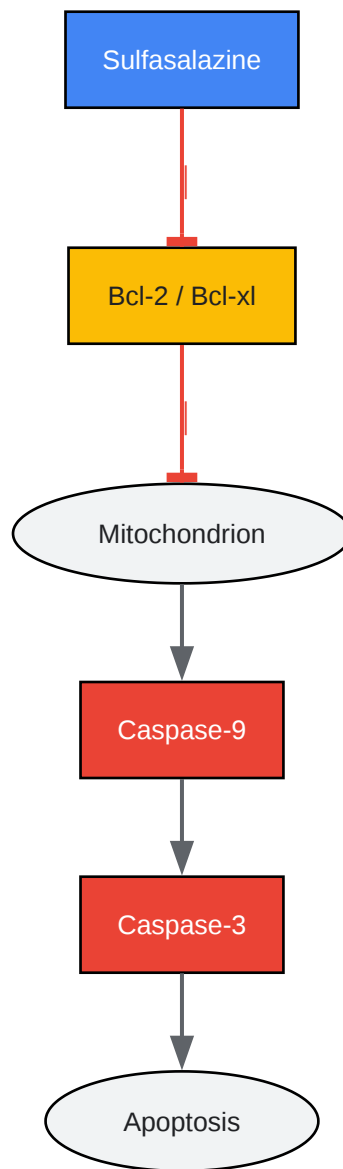

[Click to download full resolution via product page](#)

Caption: Sulfasalazine-induced mitochondrial apoptosis pathway.



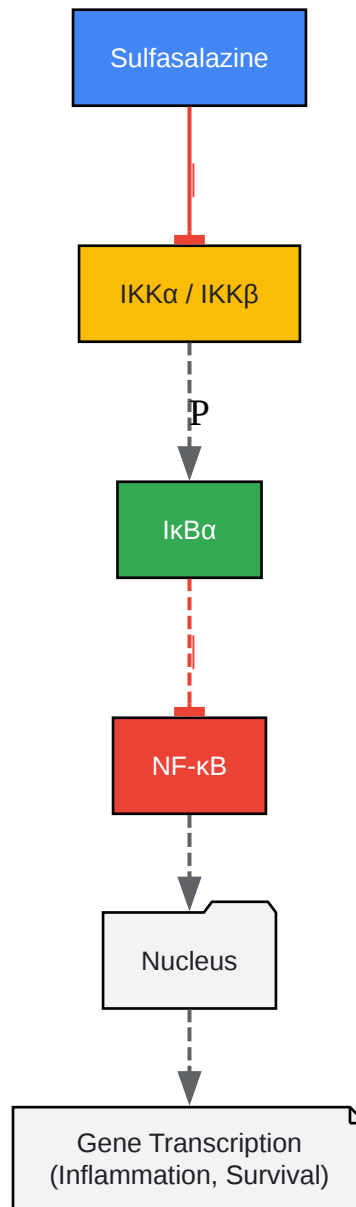

[Click to download full resolution via product page](#)

Caption: Inhibition of the NF-κB pathway by Sulfasalazine.

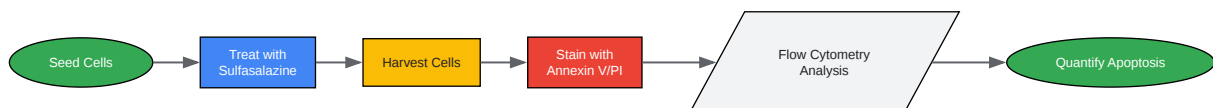

[Click to download full resolution via product page](#)

Caption: Experimental workflow for apoptosis analysis.

### Need Custom Synthesis?

BenchChem offers custom synthesis for rare earth carbides and specific isotopic labeling.

Email: [info@benchchem.com](mailto:info@benchchem.com) or [Request Quote Online](#).

## References

- 1. researchgate.net [researchgate.net]
- 2. Death Inducing and Cytoprotective Autophagy in T-47D Cells by Two Common Antibacterial Drugs: Sulfathiazole and Sulfacetamide - PMC [pmc.ncbi.nlm.nih.gov]
- To cite this document: BenchChem. [Application Notes and Protocols for Sulfonamides in In Vitro Cell Culture]. BenchChem, [2025]. [Online PDF]. Available at: [https://www.benchchem.com/product/b111562#cell-culture-applications-of-sulfabenz-in-vitro]

---

### Disclaimer & Data Validity:

The information provided in this document is for Research Use Only (RUO) and is strictly not intended for diagnostic or therapeutic procedures. While BenchChem strives to provide accurate protocols, we make no warranties, express or implied, regarding the fitness of this product for every specific experimental setup.

**Technical Support:** The protocols provided are for reference purposes. Unsure if this reagent suits your experiment? [[Contact our Ph.D. Support Team for a compatibility check](#)]

**Need Industrial/Bulk Grade?** [Request Custom Synthesis Quote](#)

# BenchChem

Our mission is to be the trusted global source of essential and advanced chemicals, empowering scientists and researchers to drive progress in science and industry.

## Contact

Address: 3281 E Guasti Rd  
Ontario, CA 91761, United States  
Phone: (601) 213-4426  
Email: [info@benchchem.com](mailto:info@benchchem.com)