

# Application Notes and Protocols for Studying hERG Channel Block with Clofilium

**Author:** BenchChem Technical Support Team. **Date:** December 2025

## Compound of Interest

Compound Name: Clofilium

Cat. No.: B1199958

[Get Quote](#)

For Researchers, Scientists, and Drug Development Professionals

These application notes provide a comprehensive guide for utilizing **clofilium** as a tool to study the function and pharmacology of the human Ether-à-go-go-Related Gene (hERG) potassium channel. The protocols detailed below are intended for researchers in academia and the pharmaceutical industry engaged in cardiac safety screening and ion channel research.

## Introduction

The hERG potassium channel is a critical component in the repolarization phase of the cardiac action potential. Blockade of this channel can lead to QT interval prolongation, a condition that increases the risk of developing life-threatening cardiac arrhythmias, most notably Torsades de Pointes (TdP). Consequently, the assessment of a compound's potential to block the hERG channel is a mandatory step in preclinical drug development.

**Clofilium** is a potent and specific blocker of the hERG channel, making it an invaluable tool for studying the channel's biophysical properties and for validating hERG assay systems. It acts as a Class III antiarrhythmic agent and is known to block the hERG channel in a voltage- and use-dependent manner, which is characteristic of an open-channel blocking mechanism.

## Quantitative Data Summary: Clofilium Potency on hERG Channels

The inhibitory potency of **clofilium** on the hERG channel is influenced by the experimental conditions, particularly the membrane potential. The half-maximal inhibitory concentration (IC50) is a key parameter for quantifying the potency of the block.

Parameter	Value	Experimental Condition	Reference
IC50	150 nM	Whole-cell patch clamp at +40 mV	[1]
IC50	250 nM	Whole-cell patch clamp at 0 mV	[1]

## Experimental Protocols

The following protocols are designed for the functional assessment of hERG channel block by **clofilium** using the whole-cell patch-clamp electrophysiology technique in mammalian cell lines (e.g., HEK293 or CHO) stably expressing the hERG channel.

## Cell Culture and Preparation

- **Cell Line Maintenance:** Culture hERG-expressing cells in the recommended medium supplemented with the appropriate selection antibiotic to ensure stable channel expression.
- **Subculturing:** Passage the cells every 2-3 days to maintain them in the logarithmic growth phase.
- **Plating for Electrophysiology:** Twenty-four to forty-eight hours before the experiment, plate the cells onto glass coverslips at a density that will result in 50-70% confluency on the day of recording. This ensures a sufficient number of healthy, isolated cells for patching.

## Solutions and Reagents

Proper solution composition is critical for maintaining cell health and obtaining accurate recordings.

Solution	Component	Concentration (mM)
Extracellular (Bath) Solution	NaCl	137
	KCl	4
	CaCl <sub>2</sub>	1.8
	MgCl <sub>2</sub>	1
	HEPES	10
	Glucose	10
pH adjusted to 7.4 with NaOH		
Intracellular (Pipette) Solution	K-Gluconate	120
	KCl	20
	MgCl <sub>2</sub>	1
	EGTA	5
	HEPES	10
	Mg-ATP	4
pH adjusted to 7.2 with KOH		
Clofilium Stock Solution	Clofilium Tosylate	10
Dissolved in DMSO		

Note: Prepare fresh dilutions of **clofilium** in the extracellular solution on the day of the experiment. The final DMSO concentration should not exceed 0.1% to avoid solvent effects.

## Whole-Cell Patch-Clamp Protocol

- Pipette Preparation: Pull patch pipettes from borosilicate glass capillaries to a resistance of 2-5 M $\Omega$  when filled with the intracellular solution.
- Cell Mounting: Place a coverslip with the hERG-expressing cells into the recording chamber on the microscope stage and perfuse with the extracellular solution.

- **Giga-seal Formation:** Approach a single, healthy cell with the patch pipette and apply gentle suction to form a high-resistance seal ( $>1\text{ G}\Omega$ ) between the pipette tip and the cell membrane.
- **Whole-Cell Configuration:** Apply a brief pulse of suction to rupture the cell membrane under the pipette tip to achieve the whole-cell recording configuration.
- **Stabilization:** Allow the cell to stabilize for 5-10 minutes to ensure dialysis of the pipette solution into the cell and for the recording to become stable.
- **Voltage-Clamp Protocol:** Apply a voltage-clamp protocol to elicit hERG currents. A typical protocol to assess for **clofilium** block is as follows:
  - Hold the membrane potential at  $-80\text{ mV}$ .
  - Apply a depolarizing step to  $+20\text{ mV}$  for 1-2 seconds to activate the hERG channels.
  - Repolarize the membrane to  $-50\text{ mV}$  to record the characteristic deactivating tail current. This tail current is used to quantify the hERG current amplitude.
- **Data Acquisition:**
  - Record baseline hERG currents in the absence of **clofilium** until a stable current amplitude is achieved.
  - Perfuse the recording chamber with increasing concentrations of **clofilium**, allowing the drug effect to reach a steady-state at each concentration before recording.
  - Perform a washout with the control extracellular solution to assess the reversibility of the block.

## Data Analysis

- **Current Measurement:** Measure the peak amplitude of the hERG tail current at each **clofilium** concentration.
- **Normalization:** Normalize the current amplitude in the presence of the drug to the control (pre-drug) current amplitude.

- Concentration-Response Curve: Plot the normalized current as a function of the **clofilium** concentration.
- IC50 Determination: Fit the concentration-response data to the Hill equation to determine the IC50 value and the Hill coefficient (nH):  $I/I_{\text{control}} = 1 / (1 + ([\text{Drug}]/\text{IC50})^{nH})$  Where:
  - I is the current in the presence of the drug.
  - I<sub>control</sub> is the control current.
  - [Drug] is the concentration of **clofilium**.

## Visualizations

### Mechanism of Clofilium Block on hERG Channel

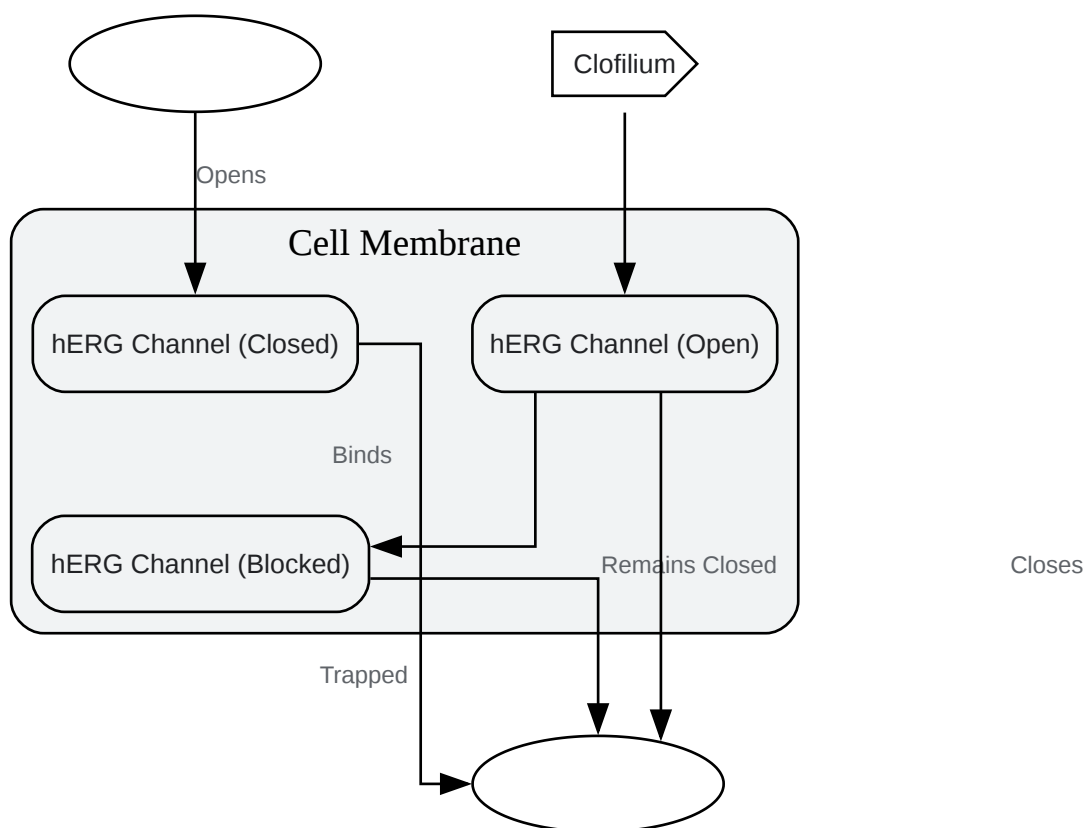

[Click to download full resolution via product page](#)

Caption: **Clofilium's** open-channel block of the hERG potassium channel.

## Experimental Workflow for hERG Assay

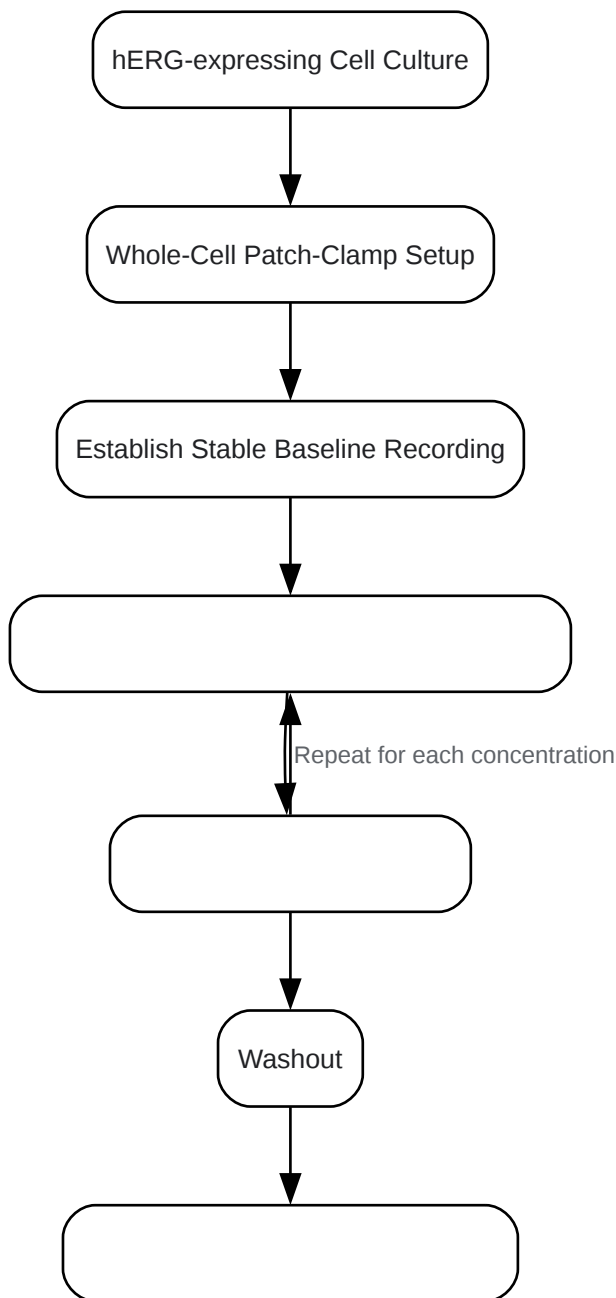

[Click to download full resolution via product page](#)

Caption: Workflow for assessing hERG channel inhibition by **clofilium**.

## Conclusion

The protocols and data presented herein provide a robust framework for studying the inhibitory effects of **clofilium** on the hERG channel. Accurate characterization of hERG channel blockers

is paramount for cardiovascular safety assessment in drug development. By adhering to these detailed methodologies, researchers can obtain reliable and reproducible data, contributing to a better understanding of drug-induced arrhythmogenesis and the development of safer medicines.

#### *Need Custom Synthesis?*

*BenchChem offers custom synthesis for rare earth carbides and specific isotopic labeling.*

*Email: [info@benchchem.com](mailto:info@benchchem.com) or [Request Quote Online](#).*

## References

- 1. Specific block of cloned Herg channels by clofilium and its tertiary analog LY97241 - PubMed [pubmed.ncbi.nlm.nih.gov]
- To cite this document: BenchChem. [Application Notes and Protocols for Studying hERG Channel Block with Clofilium]. BenchChem, [2025]. [Online PDF]. Available at: [https://www.benchchem.com/product/b1199958#clofilium-concentration-for-studying-herg-channel-block]

---

#### **Disclaimer & Data Validity:**

The information provided in this document is for Research Use Only (RUO) and is strictly not intended for diagnostic or therapeutic procedures. While BenchChem strives to provide accurate protocols, we make no warranties, express or implied, regarding the fitness of this product for every specific experimental setup.

**Technical Support:** The protocols provided are for reference purposes. Unsure if this reagent suits your experiment? [[Contact our Ph.D. Support Team for a compatibility check](#)]

**Need Industrial/Bulk Grade?** [Request Custom Synthesis Quote](#)

# BenchChem

Our mission is to be the trusted global source of essential and advanced chemicals, empowering scientists and researchers to drive progress in science and industry.

## Contact

Address: 3281 E Guasti Rd

Ontario, CA 91761, United States

Phone: (601) 213-4426

Email: [info@benchchem.com](mailto:info@benchchem.com)