

Application Notes and Protocols for Rociletinib Hydrobromide in Preclinical Research

Author: BenchChem Technical Support Team. **Date:** December 2025

Compound of Interest

Compound Name: Rociletinib hydrobromide

Cat. No.: B1139330

[Get Quote](#)

For Researchers, Scientists, and Drug Development Professionals

These application notes provide detailed information on the solubility and formulation of **rociletinib hydrobromide** for in vitro and in vivo experiments. The provided protocols are intended to serve as a guide for researchers working with this compound.

Physicochemical Properties

Rociletinib hydrobromide is the hydrobromide salt of rociletinib, an irreversible inhibitor of mutant epidermal growth factor receptor (EGFR), particularly those harboring the T790M resistance mutation.^{[1][2]}

Molecular Formula: $C_{27}H_{29}BrF_3N_7O_3$ Molecular Weight: 636.46 g/mol ^[3]

Solubility Data

The solubility of **rociletinib hydrobromide** is a critical factor for the design of both in vitro and in vivo experiments. The following tables summarize the available solubility data.

Table 1: Solubility of **Rociletinib Hydrobromide** in Common Solvents

Solvent	Solubility	Concentration (mM)	Notes
Dimethyl Sulfoxide (DMSO)	≥ 59 mg/mL	≥ 92.70 mM	Use freshly opened, anhydrous DMSO for best results as hygroscopic DMSO can impact solubility. [1]
Water	< 0.1 mg/mL	-	Practically insoluble. [1]
Ethanol	Data not available	-	-
Polyethylene Glycol 400 (PEG 400)	Data not available	-	-
Propylene Glycol (PG)	Data not available	-	-

Table 2: Aqueous Solubility of **Rociletinib Hydrobromide** at Different pH Values

pH	Aqueous Solubility	Notes
Data not available	Data not available	The solubility of weakly basic compounds can be pH-dependent.[4] Further investigation is required to determine the full pH-solubility profile.

Formulation Protocols for Experiments

In Vitro Stock Solution Preparation

For cell-based assays, a high-concentration stock solution in DMSO is recommended.

Protocol:

- Weigh the desired amount of **rociletinib hydrobromide** powder in a sterile microcentrifuge tube.
- Add the appropriate volume of anhydrous, sterile DMSO to achieve the desired stock concentration (e.g., 10 mM).
- Vortex thoroughly until the compound is completely dissolved. Gentle warming to 37°C and sonication can aid dissolution.[5]
- Aliquot the stock solution into smaller volumes to avoid repeated freeze-thaw cycles.
- Store stock solutions at -20°C for up to one month or at -80°C for up to six months.[1]

In Vivo Formulation for Oral Administration (Suspension)

For oral gavage in rodent models, a suspension can be prepared. Doses of 50 mg/kg twice daily and 100 mg/kg/day have been used in mice.[1]

Protocol:

- Prepare a stock solution of **rociletinib hydrobromide** in DMSO (e.g., 25 mg/mL).
- Prepare a 20% (w/v) solution of Captisol® (sulfobutylether-β-cyclodextrin) in sterile saline.
- To prepare the final dosing suspension (e.g., 2.5 mg/mL), add 100 μL of the DMSO stock solution to 900 μL of the 20% Captisol® solution.
- Mix thoroughly by vortexing. Use of an ultrasonic bath may be necessary to ensure a uniform suspension.[1]
- Administer the suspension immediately after preparation.

In Vivo Formulation for Intravenous Administration

A specific protocol for the intravenous formulation of **rociletinib hydrobromide** is not readily available. However, a common approach for poorly water-soluble compounds involves the use of co-solvents.

Example Co-solvent System (Adaptable for **Rociletinib Hydrobromide**):

- Vehicle: 20% Dimethyl Sulfoxide (DMSO) and 80% Polyethylene Glycol 400 (PEG400).[6]

Note: The final concentration of **rociletinib hydrobromide** in this vehicle would need to be determined empirically, ensuring complete dissolution and stability. It is crucial to perform preliminary tolerability studies in the animal model of choice.

Experimental Protocols

Cell Viability Assay (MTT/XTT)

This protocol describes a general method to assess the effect of rociletinib on the viability of cancer cell lines.

Protocol:

- Cell Seeding: Seed cells in a 96-well plate at a density of 3,000-5,000 cells per well in 100 μ L of complete growth medium. Allow cells to adhere overnight.
- Compound Treatment: Prepare serial dilutions of **rociletinib hydrobromide** from the DMSO stock solution in culture medium. The final DMSO concentration should be kept constant across all wells and should not exceed 0.5%. Replace the medium in each well with 100 μ L of the medium containing the desired concentration of rociletinib or vehicle control.
- Incubation: Incubate the plate for 72 hours at 37°C in a humidified incubator with 5% CO₂.
- MTT/XTT Addition:
 - For MTT: Add 10 μ L of 5 mg/mL MTT solution to each well and incubate for 3-4 hours at 37°C. Then, add 100 μ L of solubilization solution (e.g., 10% SDS in 0.01 M HCl) and incubate overnight at 37°C.
 - For XTT: Prepare the XTT labeling mixture according to the manufacturer's instructions. Add 50 μ L of the mixture to each well and incubate for 2-4 hours at 37°C.
- Absorbance Measurement: Read the absorbance at the appropriate wavelength (e.g., 570 nm for MTT, 450-500 nm for XTT) using a microplate reader.

- **Data Analysis:** Calculate the percentage of cell viability relative to the vehicle-treated control cells.

Western Blot for EGFR Phosphorylation

This protocol is designed to detect the inhibition of EGFR phosphorylation upon treatment with rociletinib.

Protocol:

- **Cell Culture and Treatment:** Seed cells in 6-well plates and grow to 70-80% confluency. Serum-starve the cells overnight if necessary. Treat the cells with **rociletinib hydrobromide** (e.g., 100 nM) or vehicle control for 1 hour.
- **Cell Lysis:** Wash the cells twice with ice-cold PBS. Lyse the cells on ice with RIPA buffer supplemented with protease and phosphatase inhibitors.
- **Protein Quantification:** Determine the protein concentration of the lysates using a BCA or Bradford assay.
- **Sample Preparation:** Mix 20-30 µg of protein from each sample with 4x Laemmli sample buffer and boil for 5 minutes at 95°C.
- **SDS-PAGE and Transfer:** Load the samples onto a polyacrylamide gel and separate the proteins by electrophoresis. Transfer the separated proteins to a PVDF or nitrocellulose membrane.
- **Blocking:** Block the membrane with 5% Bovine Serum Albumin (BSA) in Tris-buffered saline with 0.1% Tween-20 (TBST) for 1 hour at room temperature.
- **Primary Antibody Incubation:** Incubate the membrane with primary antibodies against phospho-EGFR (e.g., Tyr1068) and total EGFR overnight at 4°C with gentle agitation. Dilute the antibodies in 5% BSA in TBST according to the manufacturer's recommendations.
- **Washing:** Wash the membrane three times for 10 minutes each with TBST.
- **Secondary Antibody Incubation:** Incubate the membrane with an appropriate HRP-conjugated secondary antibody for 1 hour at room temperature.

- **Signal Detection:** Wash the membrane three times for 10 minutes each with TBST. Detect the signal using an enhanced chemiluminescence (ECL) substrate and an imaging system.
- **Analysis:** Quantify the band intensities and normalize the phospho-EGFR signal to the total EGFR signal.

Visualizations

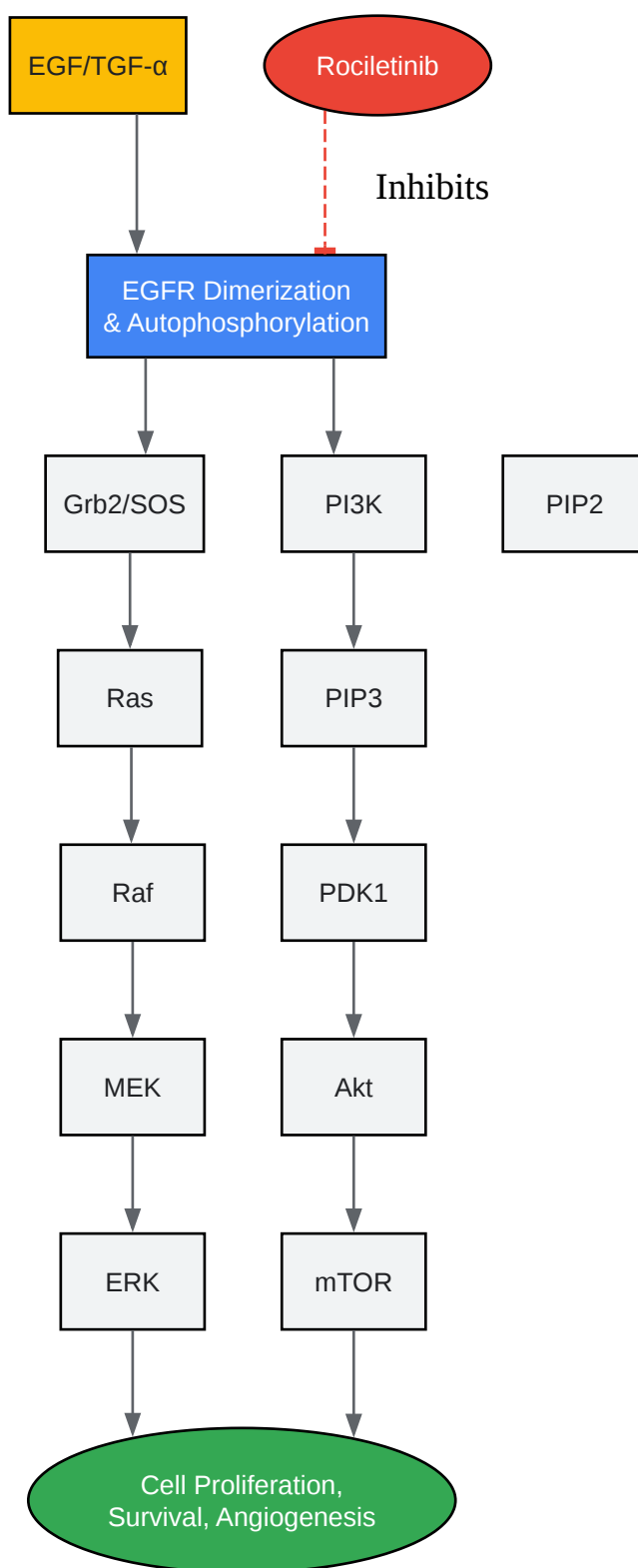

[Click to download full resolution via product page](#)

Caption: EGFR signaling pathway and the inhibitory action of rociletinib.

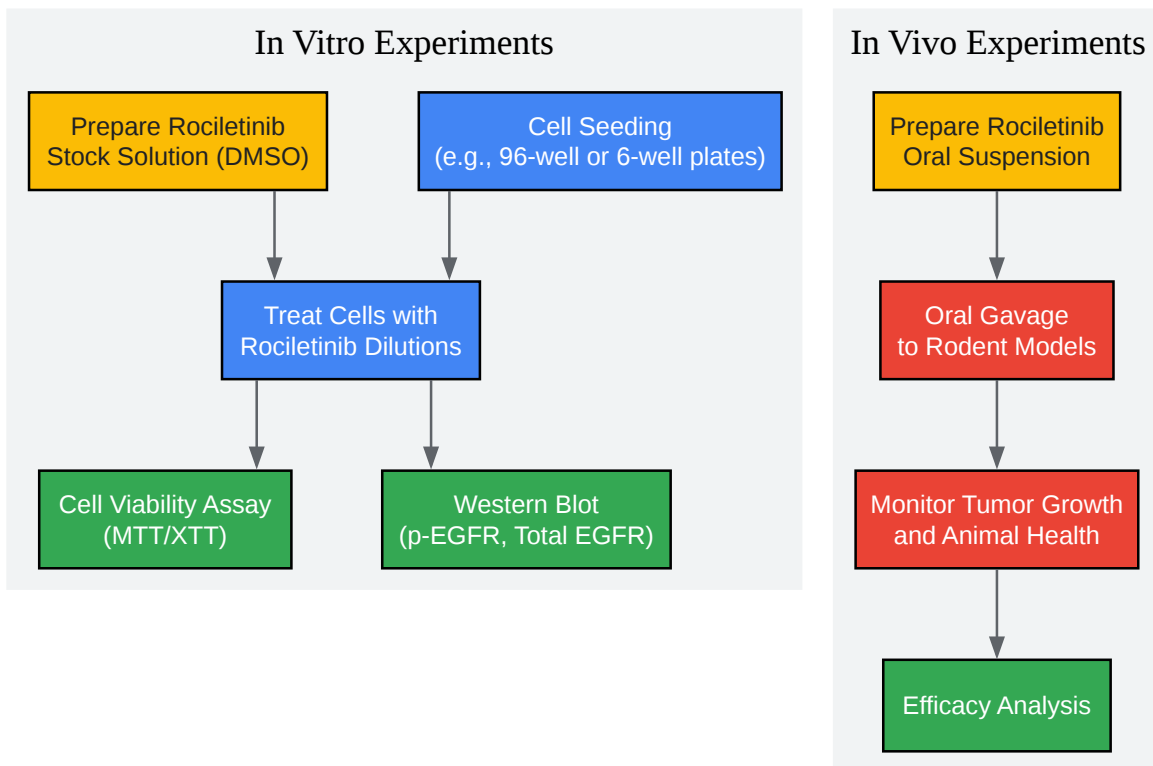

[Click to download full resolution via product page](#)

Caption: General experimental workflow for **rociletinib hydrobromide**.

Need Custom Synthesis?

BenchChem offers custom synthesis for rare earth carbides and specific isotopic labeling.

Email: info@benchchem.com or [Request Quote Online](#).

References

- 1. medchemexpress.com [medchemexpress.com]
- 2. Profile of rociletinib and its potential in the treatment of non-small-cell lung cancer - PMC [pmc.ncbi.nlm.nih.gov]
- 3. file.medchemexpress.com [file.medchemexpress.com]
- 4. Solubility, pH-Solubility Profile, pH-Rate Profile, and Kinetic Stability of the Tyrosine Kinase Inhibitor, Alectinib - PMC [pmc.ncbi.nlm.nih.gov]

- 5. glpbio.com [glpbio.com]
- 6. Early Stage Preclinical Formulation Strategies to Alter the Pharmacokinetic Profile of Two Small Molecule Therapeutics - PMC [pmc.ncbi.nlm.nih.gov]
- To cite this document: BenchChem. [Application Notes and Protocols for Rociletinib Hydrobromide in Preclinical Research]. BenchChem, [2025]. [Online PDF]. Available at: [https://www.benchchem.com/product/b1139330#rociletinib-hydrobromide-solubility-and-formulation-for-experiments]

Disclaimer & Data Validity:

The information provided in this document is for Research Use Only (RUO) and is strictly not intended for diagnostic or therapeutic procedures. While BenchChem strives to provide accurate protocols, we make no warranties, express or implied, regarding the fitness of this product for every specific experimental setup.

Technical Support: The protocols provided are for reference purposes. Unsure if this reagent suits your experiment? [[Contact our Ph.D. Support Team for a compatibility check](#)]

Need Industrial/Bulk Grade? [Request Custom Synthesis Quote](#)

BenchChem

Our mission is to be the trusted global source of essential and advanced chemicals, empowering scientists and researchers to drive progress in science and industry.

Contact

Address: 3281 E Guasti Rd

Ontario, CA 91761, United States

Phone: (601) 213-4426

Email: info@benchchem.com