

Application Notes and Protocols for (Rac)-Golgicide A in Cell Culture

Author: BenchChem Technical Support Team. **Date:** December 2025

Compound of Interest

Compound Name: (Rac)-Golgicide A

Cat. No.: B105603

[Get Quote](#)

For Researchers, Scientists, and Drug Development Professionals

Introduction

(Rac)-Golgicide A (GCA) is a potent, specific, and reversible small molecule inhibitor of Golgi-specific BFA-resistance guanine nucleotide exchange factor 1 (GBF1).[1][2][3] GBF1 is a crucial component of the cellular machinery, responsible for the activation of ADP-ribosylation factor 1 (Arf1), a small GTPase that regulates the formation of COPI-coated vesicles and the integrity of the Golgi apparatus.[4] By inhibiting GBF1, **(Rac)-Golgicide A** provides a powerful tool to dissect cellular processes involving the Golgi, including protein secretion, intracellular trafficking, and the replication of certain viruses. These application notes provide detailed protocols for the use of **(Rac)-Golgicide A** in cell culture to study its effects on Golgi structure and function.

Product Information

Parameter	Value	Reference
Synonyms	(Rac)-GCA, 6,8-Difluoro-4-pyridin-3-yl-3a,4,5,9b-tetrahydro-3H-cyclopenta[c]quinoline	
CAS Number	1005036-73-6	
Molecular Formula	C ₁₇ H ₁₄ F ₂ N ₂	
Molecular Weight	284.3 g/mol	
Solubility	Soluble in DMSO (e.g., to 50 mM), DMF, and Ethanol. Insoluble in water.	
Storage	Store the solid compound at -20°C for long-term stability (≥ 4 years). Stock solutions in DMSO can be stored at -20°C for up to 1 year or at -80°C for up to 2 years. Avoid repeated freeze-thaw cycles.	

Mechanism of Action

(Rac)-Golgicide A specifically targets GBF1, preventing the exchange of GDP for GTP on Arf1. This inhibition of Arf1 activation leads to a rapid dissociation of the COPI coat protein complex from Golgi membranes, resulting in the disassembly and dispersal of the Golgi and trans-Golgi network (TGN). This effect is reversible upon removal of the compound.

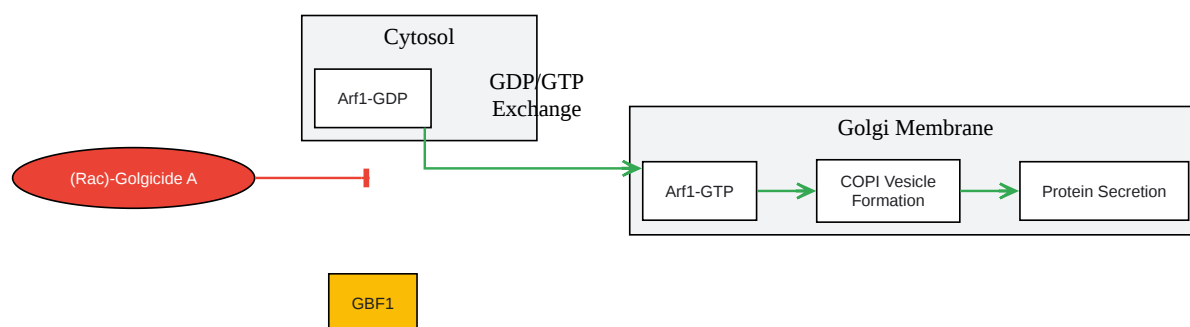

[Click to download full resolution via product page](#)

Figure 1. Signaling pathway of GBF1-mediated Arf1 activation and its inhibition by **(Rac)-Golgicide A**.

Quantitative Data Summary

Application	Cell Line	Concentration/ IC ₅₀	Effect	Reference
Inhibition of Shiga Toxin Trafficking	Vero	IC ₅₀ = 3.3 μM	Protection from Shiga toxin-induced protein synthesis inhibition.	
Inhibition of Enterovirus Replication	BGM	10 μM	Strong inhibition of Coxsackievirus B3 (CVB3) replication.	
BGM	30 μM	Complete abolishment of CVB3 replication.		
Inhibition of Hepatitis C Virus (HCV) Replication	Huh-7	10 μM	97% inhibition of HCV infection.	
Golgi Apparatus Disruption	HeLa	Not specified, but used in studies.	Induces Golgi fragmentation.	
Vero	10 μM	Complete dispersal of medial-Golgi markers.		

Experimental Protocols

General Experimental Workflow

The following diagram outlines a typical workflow for a cell-based assay using **(Rac)-Golgicide A**.

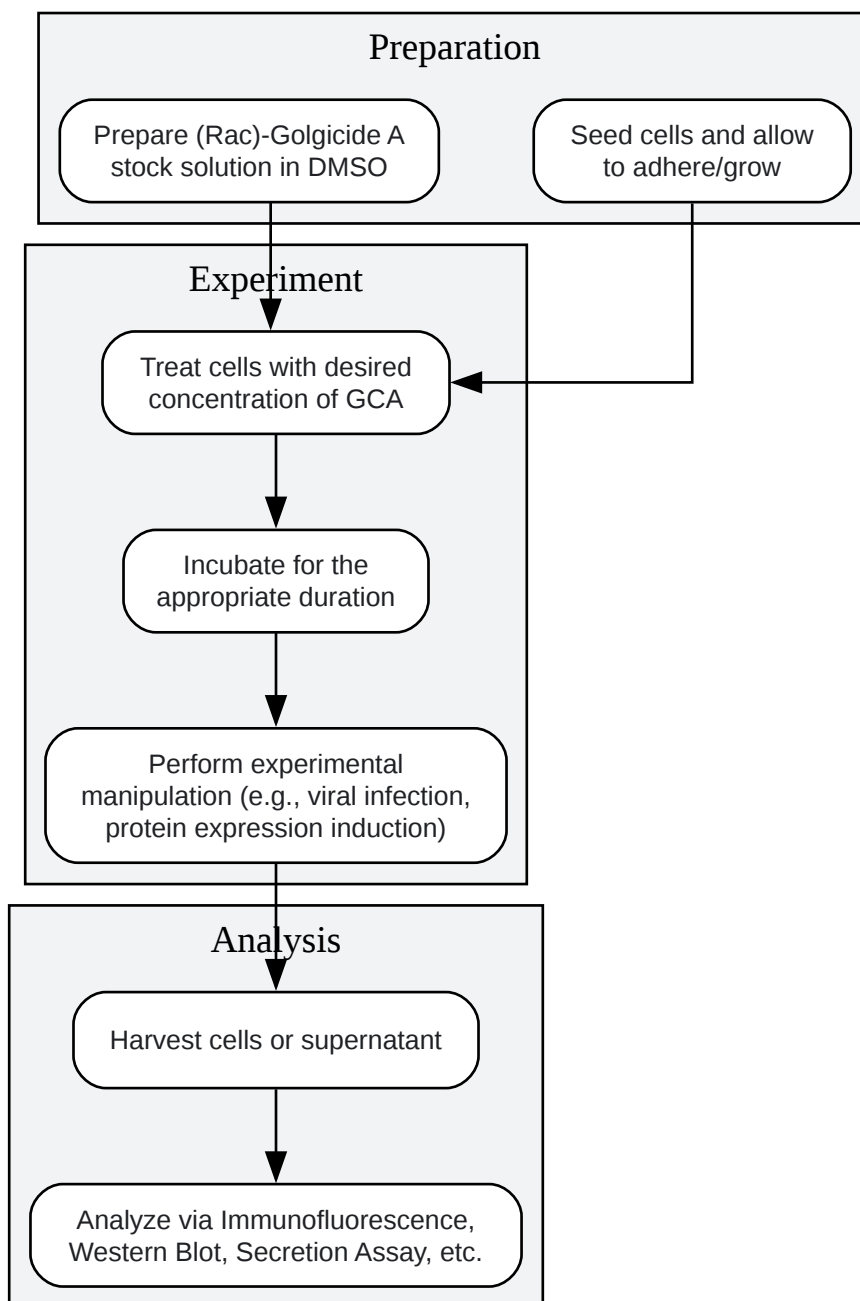

[Click to download full resolution via product page](#)

Figure 2. General experimental workflow for using (Rac)-Golgicide A in cell culture.

Protocol 1: Analysis of Golgi Apparatus Integrity by Immunofluorescence

This protocol describes how to visualize the effect of **(Rac)-Golgicide A** on the morphology of the Golgi apparatus using immunofluorescence staining of a Golgi marker protein, such as GM130 or Giantin.

Materials:

- Cells of interest (e.g., HeLa, Vero)
- Glass coverslips
- Cell culture medium
- **(Rac)-Golgicide A** stock solution (e.g., 10 mM in DMSO)
- 4% Paraformaldehyde (PFA) in PBS
- 0.1% Triton X-100 in PBS
- Blocking buffer (e.g., 1% BSA in PBS)
- Primary antibody against a Golgi marker (e.g., anti-GM130, anti-Giantin)
- Fluorescently labeled secondary antibody
- DAPI solution
- Antifade mounting medium
- Fluorescence microscope

Procedure:

- Cell Seeding: Seed cells on glass coverslips in a multi-well plate and culture until they reach the desired confluency (typically 50-70%).
- GCA Treatment: Dilute the **(Rac)-Golgicide A** stock solution in pre-warmed cell culture medium to the desired final concentration (e.g., 10 μ M). As a control, prepare a vehicle-only (DMSO) medium.

- Remove the existing medium from the cells and replace it with the GCA-containing or vehicle control medium.
- Incubate the cells for the desired time (e.g., 30 minutes to 2 hours) at 37°C in a CO₂ incubator.
- Fixation: Aspirate the medium and wash the cells once with PBS. Fix the cells with 4% PFA for 15 minutes at room temperature.
- Permeabilization: Wash the cells three times with PBS. Permeabilize the cells with 0.1% Triton X-100 in PBS for 10 minutes at room temperature.
- Blocking: Wash the cells three times with PBS. Block non-specific antibody binding by incubating the cells in blocking buffer for 1 hour at room temperature.
- Primary Antibody Incubation: Dilute the primary antibody in blocking buffer according to the manufacturer's recommendations. Incubate the coverslips with the primary antibody solution for 1 hour at room temperature or overnight at 4°C.
- Secondary Antibody Incubation: Wash the cells three times with PBS. Dilute the fluorescently labeled secondary antibody in blocking buffer. Incubate the coverslips with the secondary antibody solution for 1 hour at room temperature, protected from light.
- Nuclear Staining: Wash the cells three times with PBS. Incubate with DAPI solution for 5 minutes at room temperature to stain the nuclei.
- Mounting and Imaging: Wash the coverslips three times with PBS. Mount the coverslips onto glass slides using an antifade mounting medium.
- Image the cells using a fluorescence microscope. In control cells, the Golgi apparatus should appear as a compact, perinuclear structure. In GCA-treated cells, the Golgi will appear fragmented and dispersed throughout the cytoplasm.

Protocol 2: Protein Secretion Assay using Temperature-Sensitive Vesicular Stomatitis Virus Glycoprotein (tsO45-VSV-G)

This assay measures the effect of **(Rac)-Golgicide A** on the anterograde transport of a protein from the endoplasmic reticulum (ER) to the cell surface. It utilizes a temperature-sensitive mutant of the VSV-G protein that is retained in the ER at a restrictive temperature (40°C) and is transported to the Golgi and the cell surface at a permissive temperature (32°C).

Materials:

- Cells of interest (e.g., HeLa)
- Plasmid encoding tsO45-VSV-G-GFP
- Transfection reagent
- Cell culture medium
- **(Rac)-Golgicide A** stock solution
- Cycloheximide (optional, to inhibit new protein synthesis)
- Fluorescence microscope or flow cytometer

Procedure:

- **Transfection:** Transfect cells with the tsO45-VSV-G-GFP plasmid using a suitable transfection reagent according to the manufacturer's protocol.
- **Protein Expression and ER Retention:** After 24 hours, transfer the cells to a 40°C incubator for 16-24 hours. This allows for the expression of tsO45-VSV-G-GFP and its accumulation in the ER.
- **GCA Treatment:** Pre-warm the cell culture medium containing **(Rac)-Golgicide A** (e.g., 10 µM) and a vehicle control to 32°C. If desired, add cycloheximide (e.g., 100 µg/mL) to both media to prevent further protein synthesis.
- **Initiation of Protein Transport:** Wash the cells once with pre-warmed PBS. Add the GCA-containing or vehicle control medium to the cells and immediately transfer them to a 32°C incubator.

- Time-Course Analysis: At various time points (e.g., 0, 30, 60, 120 minutes) after the temperature shift, fix the cells and analyze the localization of tsO45-VSV-G-GFP by fluorescence microscopy.
 - At 0 minutes: The GFP signal should be localized to the ER.
 - In control cells: The GFP signal will move from the ER to the Golgi (appearing as a bright perinuclear structure) and then to the plasma membrane over time.
 - In GCA-treated cells: The GFP signal will be arrested in the ER or ER-Golgi intermediate compartment (ERGIC), demonstrating a block in protein secretion.
- Quantification (Optional): The amount of VSV-G on the cell surface can be quantified by flow cytometry using an antibody that recognizes an extracellular epitope of VSV-G on non-permeabilized cells.

Protocol 3: Antiviral Activity Assay

This protocol provides a general framework for assessing the inhibitory effect of **(Rac)-Golgicide A** on the replication of susceptible viruses, such as enteroviruses or Hepatitis C virus (HCV).

Materials:

- Host cells for the virus of interest (e.g., BGM for enteroviruses, Huh-7 for HCV)
- Virus stock with a known titer
- Cell culture medium
- **(Rac)-Golgicide A** stock solution
- Method for quantifying viral replication (e.g., plaque assay, TCID₅₀ assay, qPCR for viral RNA, or a reporter virus assay)

Procedure:

- Cell Seeding: Seed host cells in a multi-well plate and grow to a confluent monolayer.

- Pre-treatment (optional but recommended): Pre-incubate the cells with medium containing various concentrations of **(Rac)-Golgicide A** (e.g., 1 μ M, 3 μ M, 10 μ M, 30 μ M) or a vehicle control for 30 minutes to 1 hour at 37°C.
- Viral Infection: Remove the medium and infect the cells with the virus at a known multiplicity of infection (MOI) in a small volume of medium. Allow the virus to adsorb for 1-2 hours at 37°C.
- Treatment: After adsorption, remove the viral inoculum and add back the medium containing the respective concentrations of **(Rac)-Golgicide A** or vehicle control.
- Incubation: Incubate the infected cells at 37°C for a period appropriate for the virus replication cycle (e.g., 8 hours for enterovirus, 24-48 hours for HCV).
- Quantification of Viral Replication: At the end of the incubation period, quantify the extent of viral replication using a suitable method.
 - Plaque Assay/TCID₅₀: Collect the supernatant and/or cell lysate and perform serial dilutions to titer the amount of infectious virus produced.
 - qPCR: Extract total RNA from the cells and perform quantitative reverse transcription PCR (qRT-PCR) to measure the levels of viral genomic RNA.
 - Reporter Virus: If using a virus expressing a reporter gene (e.g., luciferase), lyse the cells and measure the reporter activity.
- Data Analysis: Determine the effective concentration of **(Rac)-Golgicide A** that inhibits viral replication by a certain percentage (e.g., EC₅₀). It is also important to perform a parallel cytotoxicity assay to ensure that the observed antiviral effect is not due to cell death.

Conclusion

(Rac)-Golgicide A is an invaluable tool for cell biologists and virologists. Its specific and reversible inhibition of GBF1 allows for the precise dissection of Golgi-dependent cellular pathways. The protocols provided here offer a starting point for researchers to investigate the role of GBF1 and the Golgi apparatus in their specific systems of interest. As with any

experimental system, optimization of concentrations and incubation times for specific cell lines and applications is recommended.

Need Custom Synthesis?

BenchChem offers custom synthesis for rare earth carbides and specific isotopic labeling.

Email: info@benchchem.com or [Request Quote Online](#).

References

- 1. medchemexpress.com [medchemexpress.com]
- 2. caymanchem.com [caymanchem.com]
- 3. selleckchem.com [selleckchem.com]
- 4. Golgicide A reveals essential roles for GBF1 in Golgi assembly and function - PMC [pmc.ncbi.nlm.nih.gov]
- To cite this document: BenchChem. [Application Notes and Protocols for (Rac)-Golgicide A in Cell Culture]. BenchChem, [2025]. [Online PDF]. Available at: [https://www.benchchem.com/product/b105603#rac-golgicide-a-experimental-protocol-for-cell-culture]

Disclaimer & Data Validity:

The information provided in this document is for Research Use Only (RUO) and is strictly not intended for diagnostic or therapeutic procedures. While BenchChem strives to provide accurate protocols, we make no warranties, express or implied, regarding the fitness of this product for every specific experimental setup.

Technical Support: The protocols provided are for reference purposes. Unsure if this reagent suits your experiment? [[Contact our Ph.D. Support Team for a compatibility check](#)]

Need Industrial/Bulk Grade? [Request Custom Synthesis Quote](#)

BenchChem

Our mission is to be the trusted global source of essential and advanced chemicals, empowering scientists and researchers to drive progress in science and industry.

Contact

Address: 3281 E Guasti Rd

Ontario, CA 91761, United States

Phone: (601) 213-4426

Email: info@benchchem.com