

Application Notes and Protocols for Quantitative Protein Analysis Using Acid Violet 17

Author: BenchChem Technical Support Team. **Date:** December 2025

Compound of Interest

Compound Name: Acid Violet 17

Cat. No.: B1683562

[Get Quote](#)

For Researchers, Scientists, and Drug Development Professionals

Introduction

Acid Violet 17, also known as Coomassie Violet R200, is an anionic dye utilized in various protein analysis applications, including the staining of proteins in electrophoresis gels and the enhancement of protein-rich samples such as bloodstains in forensic analysis.[1][2] Its ability to bind to proteins provides a basis for both qualitative visualization and quantitative analysis. These application notes provide detailed protocols for the use of **Acid Violet 17** in quantitative protein analysis, with a focus on gel-based methodologies.

Principle of Action

Acid Violet 17 is an acidic dye that binds to proteins, particularly to the basic amino acid residues.[3][4] This interaction is primarily electrostatic, occurring between the negatively charged sulfonic acid groups on the dye molecule and the positively charged amine groups on the proteins.[4] This binding results in a visible color change, allowing for the detection and quantification of proteins separated by electrophoretic techniques.

Quantitative Data Summary

The following table summarizes the quantitative performance characteristics of **Acid Violet 17** for protein analysis based on available data.

Parameter	Value	Notes
Linear Dynamic Range	1 - 100 μ g	Based on dye elution from stained gels and subsequent absorbance measurements.
Sensitivity	1 - 2 ng/mm ²	For selected marker proteins (e.g., bovine serum albumin, carbonic anhydrase, horse myoglobin).
Detection Method	Colorimetric (Visible)	Protein bands are visualized as purple.
Compatibility	Isoelectric focusing (IEF) gels, Polyacrylamide gels	Particularly effective for staining proteins in immobilized pH gradient gels.

Experimental Protocols

Protocol 1: Colloidal Staining of Proteins in Polyacrylamide Gels

This protocol is adapted for high-sensitivity staining of proteins in polyacrylamide gels, including those from isoelectric focusing.

Materials:

- Staining Solution: 0.1-0.2% (w/v) colloidal **Acid Violet 17** in 10% (w/v) phosphoric acid.
- Fixation Solution: 20% (w/v) trichloroacetic acid (TCA).
- Destaining Solution: 3% (w/v) phosphoric acid.
- Dye Elution Solution (for quantification): 50% (v/v) dioxane-water.
- Polyacrylamide gel with separated proteins.
- Orbital shaker.

- Spectrophotometer.

Procedure:

- **Fixation:** Immediately after electrophoresis, immerse the gel in the Fixation Solution for 30-60 minutes with gentle agitation on an orbital shaker. This step precipitates the proteins within the gel matrix.
- **Washing:** Discard the Fixation Solution and wash the gel with deionized water for 5-10 minutes to remove excess TCA.
- **Staining:** Immerse the gel in the Staining Solution for 5-10 minutes with gentle agitation. For major protein bands (100-500 ng), visualization may be possible within 0.5-3 minutes without a destaining step.
- **Destaining:** For the detection of minor protein components, transfer the gel to the Destaining Solution. The destaining time will vary from 5 to 80 minutes depending on the gel thickness and support. Monitor the gel until the protein bands are clearly visible against a faint background.
- **Image Acquisition:** After destaining, the gel can be imaged using a standard gel documentation system.
- **Quantification (Optional - By Dye Elution):**
 - a. Excise the stained protein bands from the gel.
 - b. Place the excised gel pieces into individual microcentrifuge tubes.
 - c. Add a defined volume of Dye Elution Solution to each tube.
 - d. Incubate with agitation until the dye is completely eluted from the gel piece.
 - e. Measure the absorbance of the eluted dye at the appropriate wavelength (typically around 560-600 nm, requires empirical determination for **Acid Violet 17**).
 - f. Create a standard curve using known concentrations of a standard protein (e.g., BSA) to determine the protein concentration in the samples.

Protocol 2: Staining of Protein Samples on Surfaces (Forensic Application Adaptation)

This protocol is adapted from forensic methods for enhancing protein-rich samples like bloodstains and can be used for qualitative and semi-quantitative analysis of proteins on non-porous surfaces.

Materials:

- Fixative Solution: 2% (w/v) 5-sulfosalicylic acid in deionized water.
- Staining Solution: A solution of **Acid Violet 17** in a water/acetic acid/ethanol mixture. (A typical starting formulation could be 0.1% **Acid Violet 17**, 10% acetic acid, 40% ethanol, and 50% water).
- Rinse Solution: A mixture of water, acetic acid, and ethanol in the same proportions as the staining solution, but without the dye.
- Application method: Spray bottle or immersion tray.

Procedure:

- Fixation: Apply the Fixative Solution to the surface containing the protein sample for 3-5 minutes. This prevents the protein from smearing during staining.
- Rinsing: Gently rinse the surface with deionized water to remove the fixative.
- Staining: Apply the Staining Solution to the surface for 1-3 minutes. This can be done by spraying or by immersing the object in the solution.
- Rinsing: Rinse the surface with the Rinse Solution to remove excess stain and reduce background.
- Drying: Allow the surface to air dry completely.
- Visualization and Analysis: The stained protein will appear purple. The intensity of the stain can be documented photographically for comparative analysis. For semi-quantitative analysis, densitometry can be performed on the digital images.

Visualizations

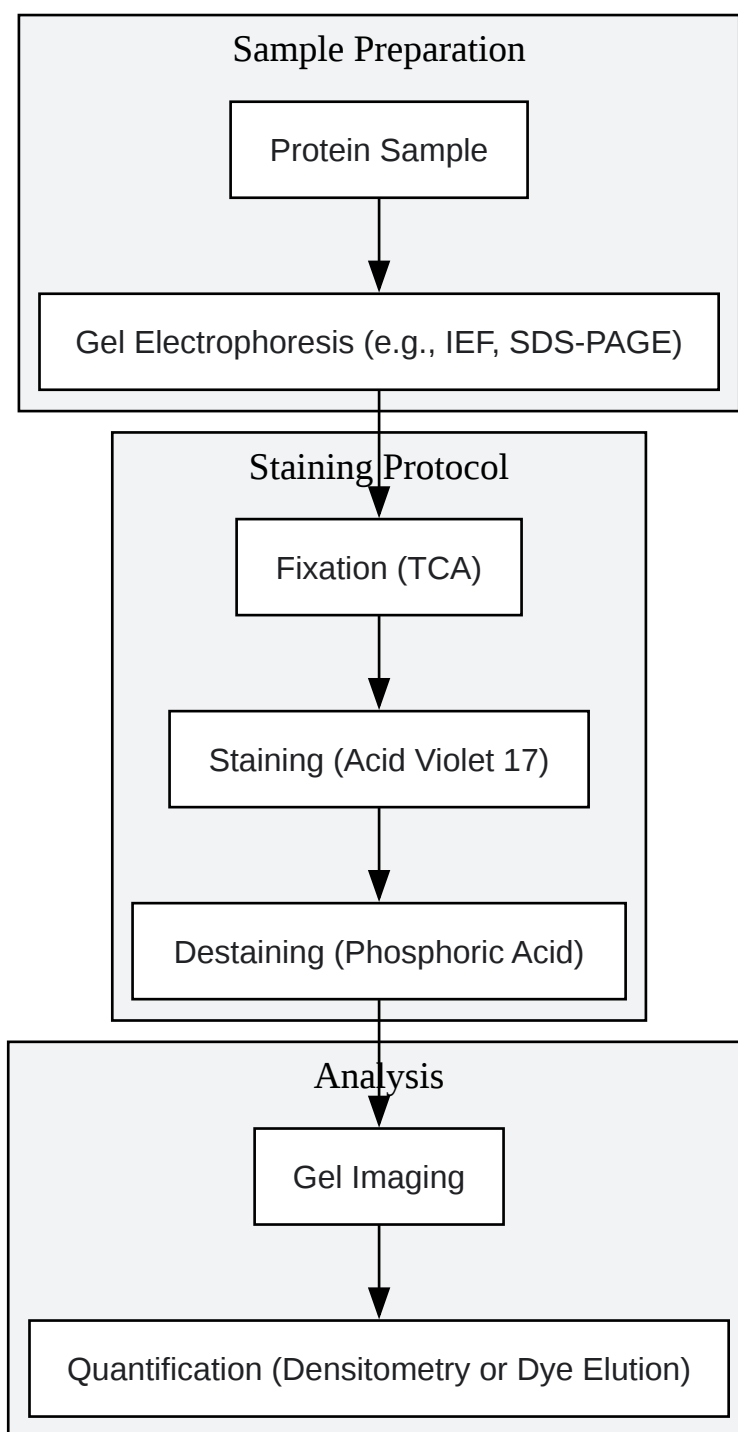

[Click to download full resolution via product page](#)

Caption: Experimental workflow for quantitative protein analysis using **Acid Violet 17**.

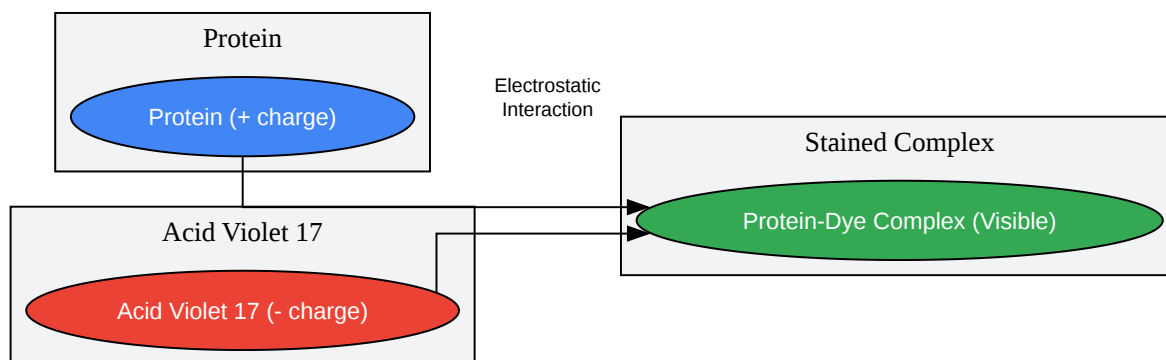

[Click to download full resolution via product page](#)

Caption: Binding mechanism of **Acid Violet 17** to proteins.

Need Custom Synthesis?

BenchChem offers custom synthesis for rare earth carbides and specific isotopic labeling.

Email: info@benchchem.com or [Request Quote Online](#).

References

- 1. scbt.com [scbt.com]
- 2. bvda.com [bvda.com]
- 3. medchemexpress.com [medchemexpress.com]
- 4. Coomassie blue staining | [Abcam](http://abcam.com) [abcam.com]
- To cite this document: BenchChem. [Application Notes and Protocols for Quantitative Protein Analysis Using Acid Violet 17]. BenchChem, [2025]. [Online PDF]. Available at: [<https://www.benchchem.com/product/b1683562#quantitative-protein-analysis-using-acid-violet-17>]

Disclaimer & Data Validity:

The information provided in this document is for Research Use Only (RUO) and is strictly not intended for diagnostic or therapeutic procedures. While BenchChem strives to provide accurate protocols, we make no warranties, express or implied, regarding the fitness of this product for every specific experimental setup.

Technical Support: The protocols provided are for reference purposes. Unsure if this reagent suits your experiment? [[Contact our Ph.D. Support Team for a compatibility check](#)]

Need Industrial/Bulk Grade? [Request Custom Synthesis Quote](#)

BenchChem

Our mission is to be the trusted global source of essential and advanced chemicals, empowering scientists and researchers to drive progress in science and industry.

Contact

Address: 3281 E Guasti Rd
Ontario, CA 91761, United States
Phone: (601) 213-4426
Email: info@benchchem.com