

Application Notes and Protocols for PQR626 In Vitro Assays

Author: BenchChem Technical Support Team. **Date:** December 2025

Compound of Interest

Compound Name: PQR626

Cat. No.: B11927594

[Get Quote](#)

For Researchers, Scientists, and Drug Development Professionals

Introduction

PQR626 is a potent, orally available, and brain-penetrant inhibitor of the mechanistic target of rapamycin (mTOR).[1][2][3] As an ATP-competitive mTOR kinase inhibitor, it targets both mTORC1 and mTORC2 complexes, which are key regulators of cell growth, proliferation, metabolism, and survival.[4][5] Dysregulation of the mTOR pathway is implicated in various diseases, including cancer and neurological disorders.[1][2][6] These application notes provide detailed protocols for key in vitro assays to characterize the activity of **PQR626**.

Data Presentation

Quantitative Efficacy of PQR626

The following table summarizes the in vitro and cellular potency of **PQR626**.

Assay Type	Target/Cell Line	Parameter	Value	Reference
Biochemical Assay				
TR-FRET Kinase Assay	mTOR	Ki	3.6 nM	[1]
TR-FRET Kinase Assay	PI3K α	Ki	>1000 nM	[1]
Cellular Assay				
In-Cell Western	A2058 cells (pPKB/Akt - Ser473)	IC50	96 nM	[1]
In-Cell Western	A2058 cells (pS6 - Ser235/236)	IC50	71 nM	[1]

Signaling Pathway

The diagram below illustrates the mTOR signaling pathway and the point of inhibition by **PQR626**.

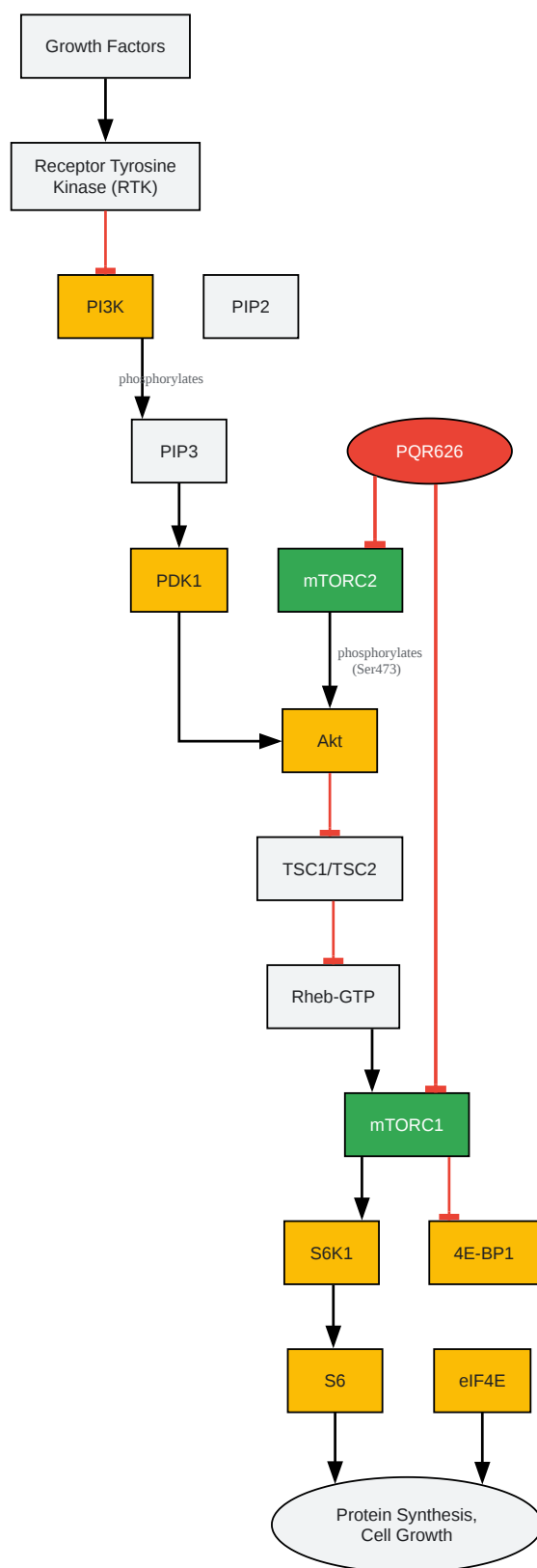

[Click to download full resolution via product page](#)

Caption: mTOR signaling pathway showing inhibition of mTORC1 and mTORC2 by **PQR626**.

Experimental Workflow

The following diagram outlines a general workflow for the in vitro characterization of **PQR626**.

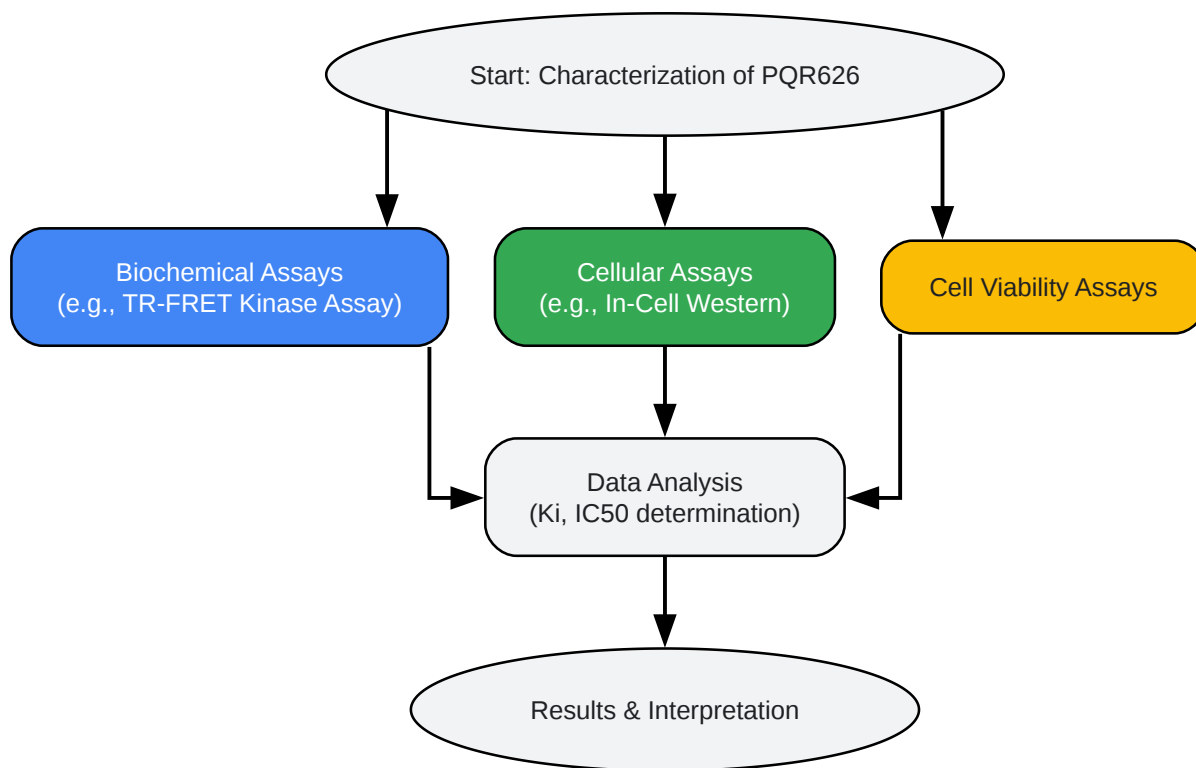

[Click to download full resolution via product page](#)

Caption: General experimental workflow for in vitro testing of **PQR626**.

Experimental Protocols

mTOR Kinase Assay (TR-FRET)

This protocol is adapted from commercially available time-resolved Förster resonance energy transfer (TR-FRET) displacement assays.^{[1][5]}

Objective: To determine the inhibitory constant (K_i) of **PQR626** against the mTOR kinase.

Materials:

- Recombinant human mTOR (truncated, GST-tagged)

- LanthaScreen™ Eu-anti-GST Antibody
- Alexa Fluor™ 647-labeled Kinase Tracer
- Assay Buffer: 50 mM HEPES pH 7.5, 5 mM MgCl₂, 1 mM EGTA, 0.01% Pluronic F-127
- **PQR626** stock solution in DMSO
- 384-well microplates

Procedure:

- Prepare a serial dilution of **PQR626** in DMSO. A 10-point, 1:4 dilution series is recommended.
- In a 384-well plate, add the diluted **PQR626** or DMSO (for control wells).
- Prepare a mix of the mTOR enzyme and the Eu-anti-GST antibody in the assay buffer. Add this mix to the wells.
- Prepare a mix of the Alexa Fluor™ 647-labeled kinase tracer in the assay buffer. Add this mix to the wells.
- Incubate the plate at room temperature for 60 minutes, protected from light.
- Read the TR-FRET signal on a compatible plate reader (excitation at 340 nm, emission at 620 nm and 665 nm).
- Calculate the emission ratio (665 nm / 620 nm).
- Determine the IC₅₀ value by fitting the data to a four-parameter logistic equation. The K_i can then be calculated using the Cheng-Prusoff equation.

In-Cell Western Assay

This protocol is for measuring the phosphorylation of mTORC1 and mTORC2 substrates in a cellular context.^[1]

Objective: To determine the IC₅₀ of **PQR626** for the inhibition of mTORC1 (pS6) and mTORC2 (pAkt) activity in cells.

Materials:

- A2058 melanoma cells
- Complete cell culture medium (e.g., DMEM with 10% FBS)
- **PQR626** stock solution in DMSO
- 96-well plates
- Fixing solution: 4% paraformaldehyde in PBS
- Permeabilization buffer: 0.1% Triton X-100 in PBS
- Blocking buffer: Odyssey Blocking Buffer or equivalent
- Primary antibodies: Rabbit anti-phospho-S6 (Ser235/236) and Mouse anti-phospho-Akt (Ser473)
- Secondary antibodies: IRDye® 800CW Goat anti-Rabbit and IRDye® 680RD Goat anti-Mouse
- DNA stain (e.g., DRAQ5™) for normalization
- Infrared imaging system (e.g., LI-COR Odyssey)

Procedure:

- Seed A2058 cells into 96-well plates at an appropriate density and allow them to adhere overnight.
- Prepare a serial dilution of **PQR626** in cell culture medium. A 7- or 11-point, 1:2 serial dilution is suggested.^[1]
- Treat the cells with the diluted **PQR626** or DMSO (vehicle control) for 1-2 hours.

- Fix the cells with the fixing solution for 20 minutes at room temperature.
- Wash the cells three times with PBS containing 0.1% Tween-20.
- Permeabilize the cells with permeabilization buffer for 20 minutes.
- Wash the cells as in step 5.
- Block the wells with blocking buffer for 1.5 hours at room temperature.
- Incubate the cells with a cocktail of the two primary antibodies diluted in blocking buffer overnight at 4°C.
- Wash the cells as in step 5.
- Incubate the cells with a cocktail of the two secondary antibodies and the DNA stain diluted in blocking buffer for 1 hour at room temperature, protected from light.
- Wash the cells as in step 5.
- Scan the plate using an infrared imaging system.
- Quantify the fluorescence intensity for each channel. Normalize the phosphoprotein signal to the DNA stain signal.
- Calculate the IC50 values by plotting the normalized signal against the logarithm of the inhibitor concentration and fitting to a sigmoidal dose-response curve.

Cell Viability Assay (Resazurin-based)

This protocol determines the effect of **PQR626** on cell proliferation and viability.

Objective: To assess the anti-proliferative effect of **PQR626** on a cancer cell line.

Materials:

- Cancer cell line of interest (e.g., SKOV3)[7]
- Complete cell culture medium

- **PQR626** stock solution in DMSO
- 96-well plates
- Resazurin sodium salt solution (0.2 mg/ml in sterile PBS)[8]
- Microplate reader capable of fluorescence measurement

Procedure:

- Seed cells in a 96-well plate at a predetermined optimal density.[8]
- Allow cells to attach and grow for 24 hours.
- Prepare a serial dilution of **PQR626** in the complete cell culture medium.
- Treat the cells with the diluted **PQR626** or DMSO (vehicle control) for 72 hours.[7]
- Add resazurin solution to each well (10% of the culture volume) and incubate for 2-4 hours at 37°C.[8]
- Measure the fluorescence with an excitation of ~560 nm and an emission of ~590 nm.
- Calculate the percentage of cell viability relative to the vehicle-treated control cells.
- Determine the GI50 (concentration for 50% growth inhibition) by plotting cell viability against the log of the **PQR626** concentration.

Need Custom Synthesis?

BenchChem offers custom synthesis for rare earth carbides and specific isotopic labeling.

Email: info@benchchem.com or [Request Quote Online](#).

References

- 1. pubs.acs.org [pubs.acs.org]

- 2. 4-(Difluoromethyl)-5-(4-((3 R,5 S)-3,5-dimethylmorpholino)-6-((R)-3-methylmorpholino)-1,3,5-triazin-2-yl)pyridin-2-amine (PQR626), a Potent, Orally Available, and Brain-Penetrant mTOR Inhibitor for the Treatment of Neurological Disorders - PubMed [pubmed.ncbi.nlm.nih.gov]
- 3. pubs.acs.org [pubs.acs.org]
- 4. researchgate.net [researchgate.net]
- 5. pubs.acs.org [pubs.acs.org]
- 6. researchgate.net [researchgate.net]
- 7. pubs.acs.org [pubs.acs.org]
- 8. Optimization of cell viability assays to improve replicability and reproducibility of cancer drug sensitivity screens - PMC [pmc.ncbi.nlm.nih.gov]
- To cite this document: BenchChem. [Application Notes and Protocols for PQR626 In Vitro Assays]. BenchChem, [2025]. [Online PDF]. Available at: [https://www.benchchem.com/product/b11927594#pqr626-in-vitro-assay-protocol]

Disclaimer & Data Validity:

The information provided in this document is for Research Use Only (RUO) and is strictly not intended for diagnostic or therapeutic procedures. While BenchChem strives to provide accurate protocols, we make no warranties, express or implied, regarding the fitness of this product for every specific experimental setup.

Technical Support: The protocols provided are for reference purposes. Unsure if this reagent suits your experiment? [[Contact our Ph.D. Support Team for a compatibility check](#)]

Need Industrial/Bulk Grade? [Request Custom Synthesis Quote](#)

BenchChem

Our mission is to be the trusted global source of essential and advanced chemicals, empowering scientists and researchers to drive progress in science and industry.

Contact

Address: 3281 E Guasti Rd
Ontario, CA 91761, United States
Phone: (601) 213-4426
Email: info@benchchem.com

