

Application Notes and Protocols for Niranthin Efficacy Studies

Author: BenchChem Technical Support Team. **Date:** December 2025

Compound of Interest

Compound Name: Niranthin

Cat. No.: B1253582

[Get Quote](#)

Introduction

Niranthin, a lignan isolated from plants of the *Phyllanthus* genus, has demonstrated a range of promising pharmacological activities, including anti-inflammatory, hepatoprotective, and anticancer effects.[1][2][3] These application notes provide detailed experimental designs and protocols for researchers, scientists, and drug development professionals to investigate the efficacy of **niranthin** in these key therapeutic areas. The following sections outline in vitro and in vivo methodologies, data presentation guidelines, and visual representations of experimental workflows and signaling pathways.

I. Anti-inflammatory Efficacy of Niranthin

Niranthin has been shown to exert its anti-inflammatory effects by downregulating key signaling pathways, including NF- κ B, MAPKs, and PI3K-Akt.[1][4] The following protocols are designed to elucidate and quantify the anti-inflammatory potential of **niranthin**.

A. In Vitro Anti-inflammatory Studies

1. Cell Culture and Treatment:

- Cell Line: Human monocytic cell line (U937) or RAW 264.7 murine macrophage cell line.
- Culture Conditions: RPMI-1640 medium supplemented with 10% fetal bovine serum (FBS), 100 U/mL penicillin, and 100 μ g/mL streptomycin at 37°C in a humidified 5% CO₂ incubator.

- Differentiation (for U937): Induce differentiation into macrophages by treating with phorbol 12-myristate 13-acetate (PMA) (100 ng/mL) for 48 hours.
- Treatment Protocol: Pre-treat differentiated macrophages with various concentrations of **niranthin** (e.g., 1, 5, 10, 25, 50 μ M) for 2 hours, followed by stimulation with lipopolysaccharide (LPS) (1 μ g/mL) for 24 hours to induce an inflammatory response.

2. Key Experimental Protocols:

- Protocol 1: Determination of Pro-inflammatory Cytokine Production by ELISA
 - After treatment, collect the cell culture supernatants.
 - Centrifuge at 1500 rpm for 10 minutes to remove cellular debris.
 - Measure the concentrations of TNF- α , IL-1 β , and IL-6 in the supernatants using commercially available ELISA kits, following the manufacturer's instructions.
 - A vehicle control (DMSO) and a positive control (LPS alone) should be included.
- Protocol 2: Analysis of COX-2 and iNOS Expression by Western Blot
 - Lyse the cells with RIPA buffer containing protease and phosphatase inhibitors.
 - Determine protein concentration using a BCA protein assay kit.
 - Separate equal amounts of protein (20-30 μ g) on a 10% SDS-PAGE gel and transfer to a PVDF membrane.
 - Block the membrane with 5% non-fat milk in TBST for 1 hour at room temperature.
 - Incubate the membrane with primary antibodies against COX-2, iNOS, and a loading control (β -actin or GAPDH) overnight at 4°C.
 - Wash the membrane with TBST and incubate with HRP-conjugated secondary antibodies for 1 hour at room temperature.

- Visualize the protein bands using an enhanced chemiluminescence (ECL) detection system.
- Protocol 3: Gene Expression Analysis of Pro-inflammatory Mediators by qRT-PCR
 - Isolate total RNA from the treated cells using a suitable RNA isolation kit.
 - Synthesize cDNA from 1 µg of total RNA using a reverse transcription kit.
 - Perform quantitative real-time PCR (qRT-PCR) using SYBR Green master mix and specific primers for TNF- α , IL-1 β , IL-6, COX-2, iNOS, and a housekeeping gene (e.g., GAPDH or ACTB).
 - The relative gene expression can be calculated using the $2^{-\Delta\Delta C_t}$ method.

B. In Vivo Anti-inflammatory Studies

- Animal Model: Carrageenan-induced paw edema in mice or rats.
- Treatment Protocol:
 - Administer **niranthin** orally or intraperitoneally at different doses (e.g., 10, 25, 50 mg/kg) one hour before inducing inflammation.
 - Inject 1% carrageenan solution subcutaneously into the plantar surface of the right hind paw.
 - Measure the paw volume or thickness at regular intervals (e.g., 1, 2, 3, 4, and 5 hours) after carrageenan injection using a plethysmometer.
 - A vehicle control group and a positive control group (e.g., treated with indomethacin) should be included.
- Data Analysis: Calculate the percentage of inhibition of edema for each group compared to the vehicle control group.

C. Data Presentation: Anti-inflammatory Efficacy

Parameter	In Vitro Assay	In Vivo Model	Quantitative Data
Cytokine Levels	ELISA	-	IC50 values (μM) for TNF- α , IL-1 β , IL-6 inhibition
Protein Expression	Western Blot	-	Fold change in COX-2 and iNOS protein levels
Gene Expression	qRT-PCR	-	Fold change in mRNA expression of inflammatory genes
Paw Edema	-	Carrageenan-induced paw edema	Percentage inhibition of paw volume

D. Signaling Pathway and Workflow Diagrams

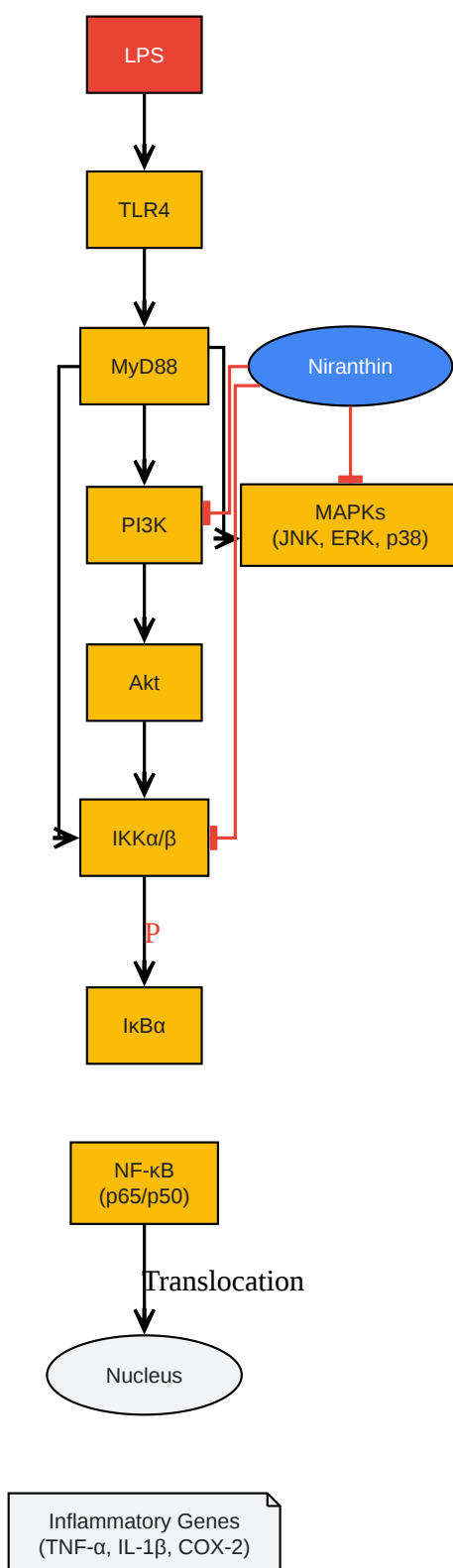

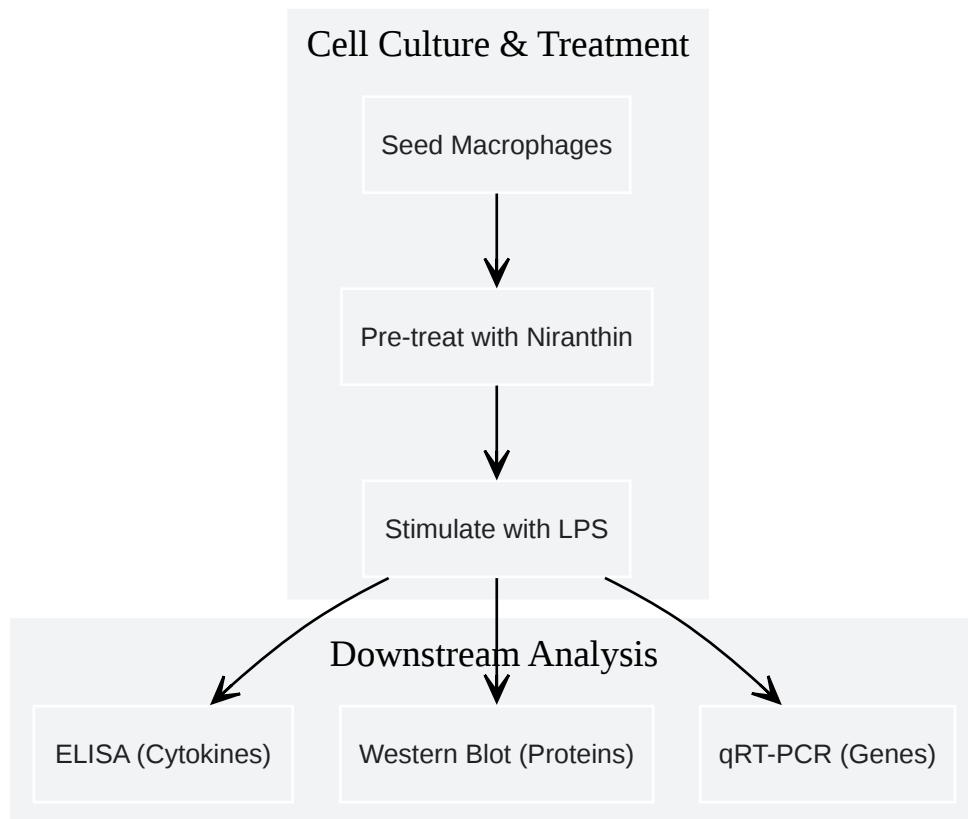

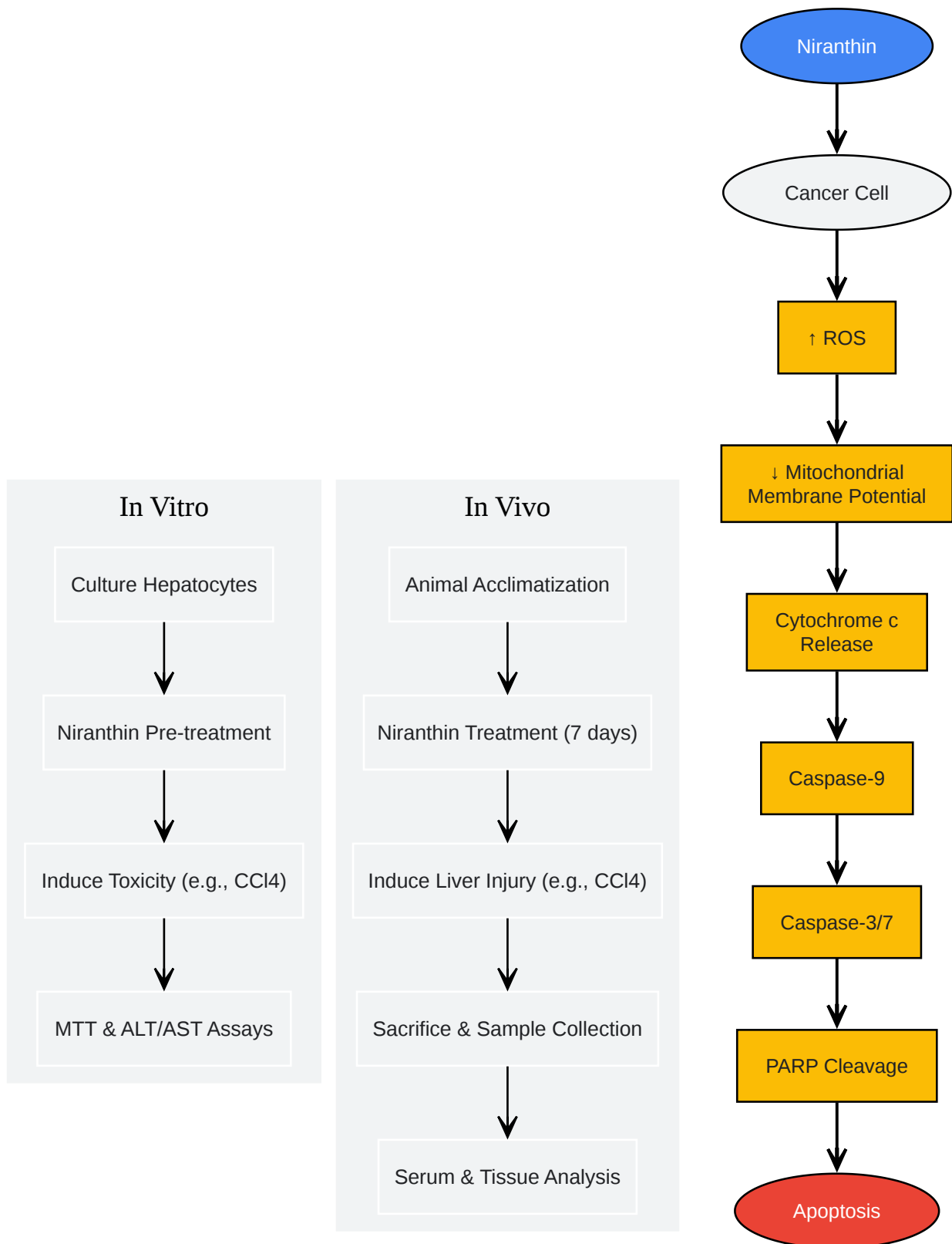

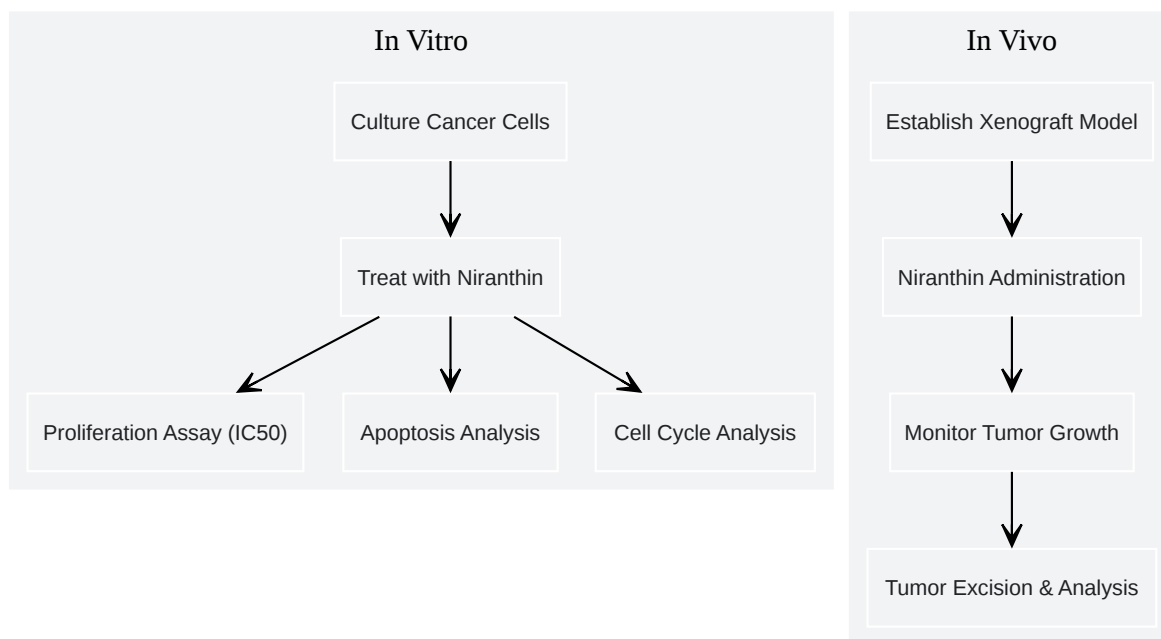

[Click to download full resolution via product page](#)

Need Custom Synthesis?

BenchChem offers custom synthesis for rare earth carbides and specific isotopic labeling.

Email: info@benchchem.com or [Request Quote Online](#).

References

- 1. Anti-Inflammatory Effects of Hypophyllanthin and Niranthin Through Downregulation of NF- κ B/MAPKs/PI3K-Akt Signaling Pathways - PubMed [pubmed.ncbi.nlm.nih.gov]
- 2. Phyllanthus Lignans: A Review of Biological Activity and Elicitation [mdpi.com]
- 3. researchgate.net [researchgate.net]
- 4. Anti-inflammatory effects of Phyllanthus amarus Schum. & Thonn. through inhibition of NF- κ B, MAPK, and PI3K-Akt signaling pathways in LPS-induced human macrophages - PMC [pmc.ncbi.nlm.nih.gov]

- To cite this document: BenchChem. [Application Notes and Protocols for Niranthin Efficacy Studies]. BenchChem, [2025]. [Online PDF]. Available at: [https://www.benchchem.com/product/b1253582#experimental-design-for-niranthin-efficacy-studies]

Disclaimer & Data Validity:

The information provided in this document is for Research Use Only (RUO) and is strictly not intended for diagnostic or therapeutic procedures. While BenchChem strives to provide accurate protocols, we make no warranties, express or implied, regarding the fitness of this product for every specific experimental setup.

Technical Support: The protocols provided are for reference purposes. Unsure if this reagent suits your experiment? [[Contact our Ph.D. Support Team for a compatibility check](#)]

Need Industrial/Bulk Grade? [Request Custom Synthesis Quote](#)

BenchChem

Our mission is to be the trusted global source of essential and advanced chemicals, empowering scientists and researchers to drive progress in science and industry.

Contact

Address: 3281 E Guasti Rd
Ontario, CA 91761, United States
Phone: (601) 213-4426
Email: info@benchchem.com