

Application Notes and Protocols for Monitoring Herqueline Stability in Solution

Author: BenchChem Technical Support Team. **Date:** December 2025

Compound of Interest

Compound Name: *Herqueline*

Cat. No.: *B1201393*

[Get Quote](#)

For Researchers, Scientists, and Drug Development Professionals

These application notes provide a comprehensive framework for assessing the stability of the novel compound **Herqueline** in solution. The following protocols are designed to establish the intrinsic stability of **Herqueline**, identify potential degradation products, and develop a validated stability-indicating analytical method. Such studies are critical in pharmaceutical development to ensure the safety, efficacy, and quality of a drug substance.^{[1][2][3]}

Introduction to Stability Testing

The chemical stability of a pharmaceutical molecule is a critical attribute that can impact its safety and efficacy. Stability testing evaluates how a product's quality changes over time under the influence of environmental factors such as temperature, humidity, and light. For novel compounds like **Herqueline**, early assessment of stability is crucial for guiding formulation development, defining proper storage conditions, and establishing a shelf-life.^{[2][3]}

Forced degradation, or stress testing, is a key component of stability studies.^[4] It involves subjecting the compound to conditions more severe than accelerated stability testing to identify likely degradation pathways and products.^[3] This information is instrumental in developing and validating stability-indicating analytical methods, which are essential for accurately quantifying the active pharmaceutical ingredient (API) without interference from its degradants.^{[3][4][5]} A variety of analytical techniques are employed in stability testing, with High-Performance Liquid Chromatography (HPLC) being one of the most frequently used due to its sensitivity and versatility in separating and quantifying the API and its degradation products. Mass

spectrometry (MS) and nuclear magnetic resonance (NMR) spectroscopy are also invaluable for the structural elucidation of these degradation products.[4]

Application Note 1: Forced Degradation Study of Herqueline

This study aims to investigate the intrinsic stability of **Herqueline** by subjecting it to various stress conditions as mandated by regulatory guidelines. The goal is to understand its degradation profile and identify the conditions under which it is most susceptible to degradation.

Experimental Workflow for Forced Degradation

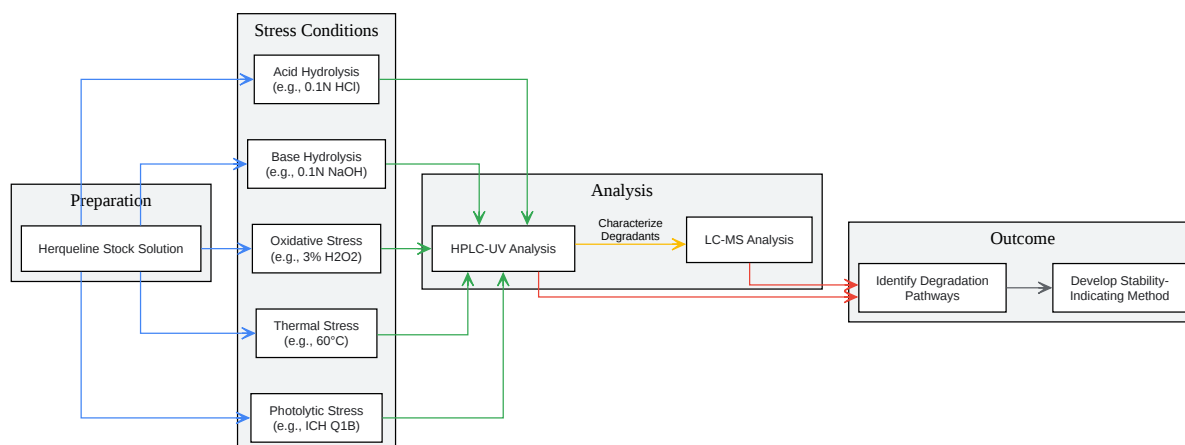

[Click to download full resolution via product page](#)

Forced degradation experimental workflow.

Protocol: Forced Degradation of Herqueline

1. Materials and Reagents:

- **Herqueline** reference standard
- HPLC-grade acetonitrile and water
- Formic acid (or other suitable buffer component)
- Hydrochloric acid (HCl)
- Sodium hydroxide (NaOH)
- Hydrogen peroxide (H₂O₂)
- Class A volumetric flasks and pipettes
- pH meter
- HPLC-UV system
- LC-MS system
- Photostability chamber
- Temperature-controlled oven/water bath

2. Preparation of Stock and Stress Solutions:

- **Herqueline** Stock Solution: Accurately weigh and dissolve **Herqueline** in a suitable solvent (e.g., 50:50 acetonitrile:water) to prepare a 1 mg/mL stock solution.
- Stress Solutions: Prepare solutions of 0.1N HCl, 0.1N NaOH, and 3% H₂O₂.

3. Stress Conditions:

- Acid Hydrolysis: Mix equal volumes of **Herqueline** stock solution and 0.1N HCl. Incubate at 60°C for predetermined time points (e.g., 2, 4, 8, 24 hours). At each time point, withdraw an

aliquot, neutralize with an equivalent amount of 0.1N NaOH, and dilute to a suitable concentration for HPLC analysis.

- Base Hydrolysis: Mix equal volumes of **Herqueline** stock solution and 0.1N NaOH. Incubate at room temperature for predetermined time points. At each time point, withdraw an aliquot, neutralize with 0.1N HCl, and dilute for analysis.
- Oxidative Degradation: Mix equal volumes of **Herqueline** stock solution and 3% H₂O₂. Incubate at room temperature, protected from light, for predetermined time points. Dilute for analysis.
- Thermal Degradation: Place the **Herqueline** stock solution in an oven at 60°C. Withdraw aliquots at predetermined time points. Also, prepare a solid sample of **Herqueline** and expose it to the same conditions.
- Photolytic Degradation: Expose the **Herqueline** stock solution and a solid sample to light providing an overall illumination of not less than 1.2 million lux hours and an integrated near-ultraviolet energy of not less than 200 watt-hours/square meter (as per ICH Q1B guidelines). A control sample should be kept in the dark under the same temperature conditions.

4. Analysis:

- Analyze all samples by a suitable stability-indicating HPLC-UV method (see Application Note 2).
- Calculate the percentage degradation of **Herqueline** and the formation of degradation products.
- Characterize significant degradation products using LC-MS.

Data Presentation: Forced Degradation of Herqueline

Stress Condition	Time (hours)	Herqueline Assay (%)	Degradation Product 1 (Area %)	Degradation Product 2 (Area %)	Total Degradation (%)
0.1N HCl, 60°C	0	100.0	ND	ND	0.0
	8	92.5	4.8	1.2	7.5
	24	85.3	9.7	2.5	14.7
0.1N NaOH, RT	0	100.0	ND	ND	0.0
	8	78.1	15.6	ND	21.9
	24	60.2	28.9	1.1	39.8
3% H ₂ O ₂ , RT	0	100.0	ND	ND	0.0
	8	98.2	1.1	ND	1.8
	24	95.6	2.9	ND	4.4
Thermal, 60°C	0	100.0	ND	ND	0.0
	24	99.1	0.5	ND	0.9
Photolytic	24	97.8	ND	1.5	2.2

ND: Not Detected

Application Note 2: Stability-Indicating HPLC-UV Method for Herqueline

A validated stability-indicating HPLC method is crucial for the accurate determination of **Herqueline** in the presence of its degradation products, excipients, and any other potential impurities.

Analytical Workflow for Stability Testing

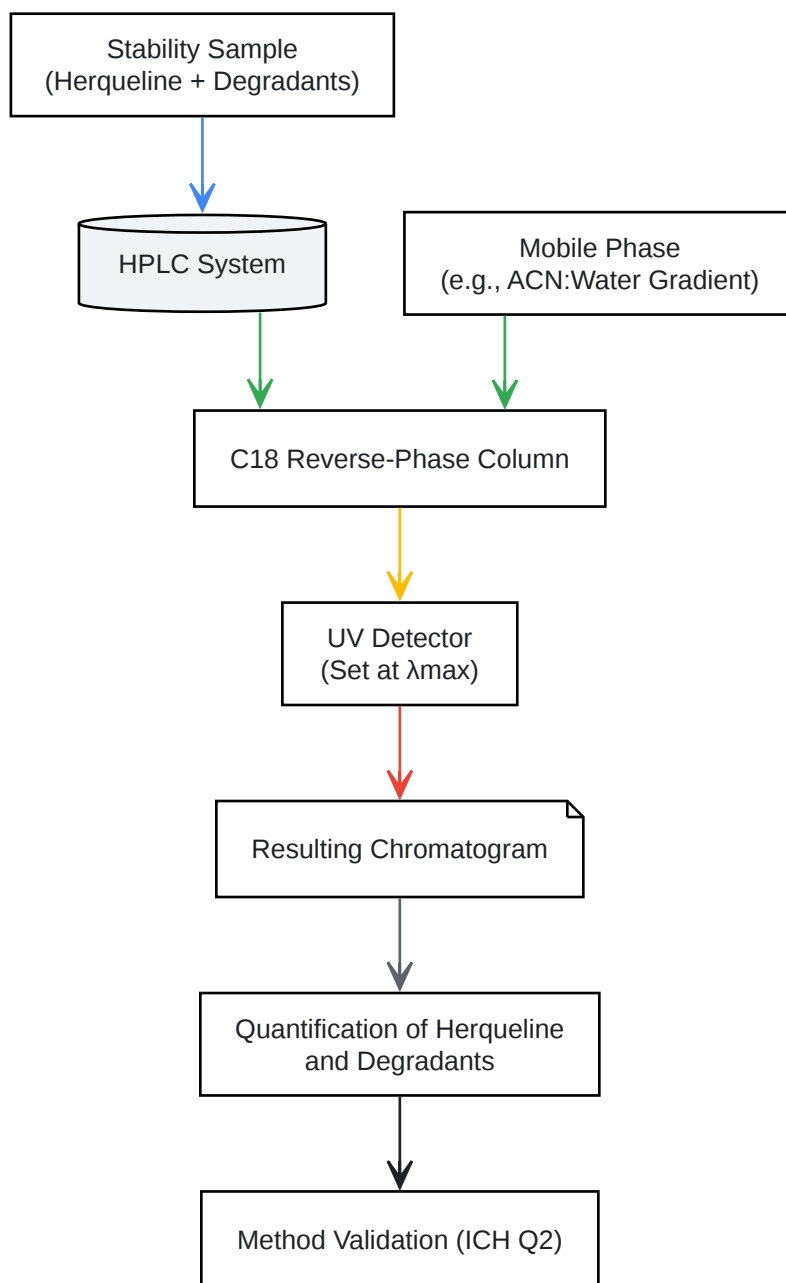

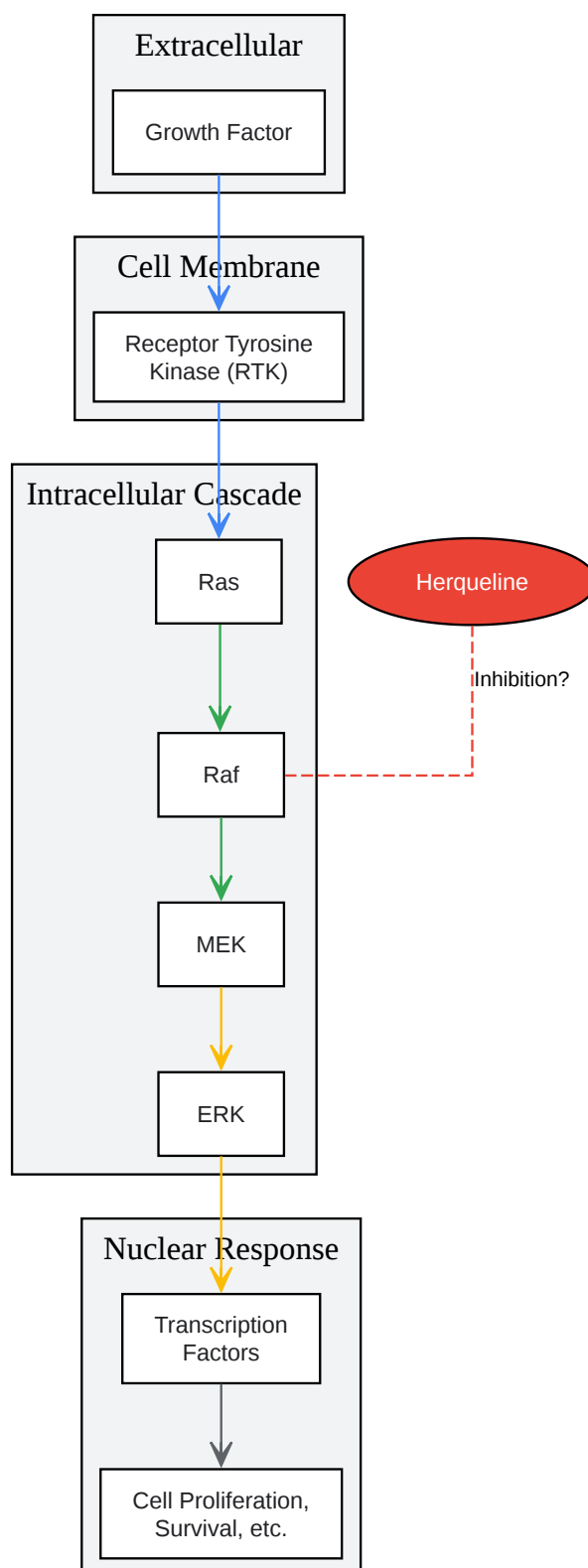

[Click to download full resolution via product page](#)

Need Custom Synthesis?

BenchChem offers custom synthesis for rare earth carbides and specific isotopic labeling.

Email: info@benchchem.com or [Request Quote Online](#).

References

- 1. chromatographyonline.com [chromatographyonline.com]
- 2. Forced Degradation in Pharmaceuticals & Pharmaceuticals A Regulatory Update [article.sapub.org]
- 3. Development of forced degradation and stability indicating studies of drugs—A review - PMC [pmc.ncbi.nlm.nih.gov]
- 4. acdlabs.com [acdlabs.com]
- 5. forced degradation products: Topics by Science.gov [science.gov]
- To cite this document: BenchChem. [Application Notes and Protocols for Monitoring Herqueline Stability in Solution]. BenchChem, [2025]. [Online PDF]. Available at: [https://www.benchchem.com/product/b1201393#techniques-for-monitoring-herqueline-stability-in-solution]

Disclaimer & Data Validity:

The information provided in this document is for Research Use Only (RUO) and is strictly not intended for diagnostic or therapeutic procedures. While BenchChem strives to provide accurate protocols, we make no warranties, express or implied, regarding the fitness of this product for every specific experimental setup.

Technical Support: The protocols provided are for reference purposes. Unsure if this reagent suits your experiment? [[Contact our Ph.D. Support Team for a compatibility check](#)]

Need Industrial/Bulk Grade? [Request Custom Synthesis Quote](#)

BenchChem

Our mission is to be the trusted global source of essential and advanced chemicals, empowering scientists and researchers to drive progress in science and industry.

Contact

Address: 3281 E Guasti Rd

Ontario, CA 91761, United States

Phone: (601) 213-4426

Email: info@benchchem.com