

Application Notes and Protocols for Melem-Based Polymers in Energy Storage

Author: BenchChem Technical Support Team. **Date:** December 2025

Compound of Interest

Compound Name: Melem

Cat. No.: B072624

[Get Quote](#)

For Researchers, Scientists, and Drug Development Professionals

These application notes provide a comprehensive overview of the synthesis, characterization, and application of **melem**-based polymers for energy storage devices, including supercapacitors and various ion batteries. Detailed experimental protocols and comparative performance data are presented to guide researchers in this emerging field.

I. Introduction to Melem-Based Polymers for Energy Storage

Melem, a tri-s-triazine (heptazine) ring-containing molecule, serves as a robust building block for nitrogen-rich polymers. These polymers are gaining significant attention in energy storage due to their exceptional thermal and chemical stability, inherent porosity, and redox-active nitrogen sites. The tunable nature of **melem**-based polymers, through the selection of co-monomers and synthesis conditions, allows for the tailoring of their electrochemical properties for specific applications such as supercapacitors, lithium-ion batteries (Li-ion), sodium-ion batteries (Na-ion), and zinc-ion batteries (Zn-ion).

II. Data Presentation: Performance of Melem-Based Polymers

The following tables summarize the key performance metrics of various **melem**-based polymers in different energy storage applications.

Table 1: **Melem**-Based Polymers for Supercapacitors

Polymer System	Specific Capacitance (F/g)	Current Density (A/g)	Cycling Stability (% retention after cycles)	Reference
Melamine-glutaraldehyde (MAGA)-PMMA Nanofibers (5%)	1377.5	1	98% after 7000 cycles	[1]
Melamine-glutaraldehyde (MAGA) derived N-doped Carbon on Ni Foam (NC/NF-400)	297	1	90% after 5000 cycles	[2]
Melamine-based Metal-Organic Framework (Co-Me)	1267.36	1	>90% after 10,000 cycles	[3]
Melamine-based Metal-Organic Framework (Ni-Me)	803.22	1	>90% after 10,000 cycles	[3]
Melamine-based Metal-Organic Framework (Fe-Me)	507.59	1	>90% after 10,000 cycles	[3]

 Table 2: **Melem**-Based Polymers for Ion Batteries

Polymer System	Battery Type	Specific Capacity (mAh/g)	Current Rate/Density	Cycling Stability (% retention after cycles)	Reference
Melem-PDI-CNT	Li-ion	~125 (initial)	50 mA/g	Excellent stability over 5000 cycles at 500 mA/g	[4]
Melem-PDI-CNT	Mg-ion	~75 (initial)	200 mA/g	Stable for over 100 cycles	[4]
Melamine Foam-derived PANI/CF	Zn-ion	215	1 A/g	88% after 2500 cycles	[5]
Phosphonate-based Gel Polymer Electrolyte	Na-ion	110.7 (for Na ₃ V ₂ (PO ₄) ₃ cathode)	1C	69.2% after 10,000 cycles at 5C	[6]
P2-Na _{0.67} Co _{0.5} Mn _{0.5} O ₂ with polymer binder	Na-ion	147	0.1C	~100% after 100 cycles at 1C	[7]

III. Experimental Protocols

A. Synthesis of Melem-Based Polymers

1. Protocol for Synthesis of Melamine-Glutaraldehyde (MAGA) Polymer[1]

- Materials: Melamine, Glutaraldehyde solution (2.5 wt%), Deionized water.
- Equipment: Beaker, Ultrasonic bath, Oven.

- Procedure:
 - Disperse 5 g of melamine in 15 mL of 2.5 wt% glutaraldehyde solution in a beaker.
 - Place the beaker in an ultrasonic bath at 60 °C for 30 minutes to ensure uniform dispersion.
 - Transfer the beaker to an oven and maintain the temperature at 85 °C for 3 days to allow for polymerization.
 - After 3 days, filter the resulting white polymer precipitate.
 - Wash the polymer thoroughly with deionized water to remove any unreacted monomers and glutaraldehyde.
 - Dry the polymer in a vacuum oven at 60 °C overnight.

2. Protocol for Synthesis of **Melem**-Perylenetetracarboxylic Dianhydride (**Melem**-PDI) Polymer^{[3][4]}

- Materials: **Melem** (2,5,8-triamino-tri-s-triazine), Perylenetetracarboxylic dianhydride (PTCDA), Zinc (II) chloride (ZnCl₂), Potassium chloride (KCl), Sodium chloride (NaCl).
- Equipment: Schlenk tube or similar reaction vessel, Tube furnace, Inert gas supply (e.g., Argon or Nitrogen).
- Procedure:
 - In a Schlenk tube, thoroughly mix **melem**, PTCDA, ZnCl₂, KCl, and NaCl in a molar ratio of 1:1:5:1:1.
 - Heat the mixture in a tube furnace under an inert atmosphere to 250 °C.
 - Maintain the temperature at 250 °C for 3 days to facilitate the ionothermal polymerization.
 - After cooling to room temperature, wash the solid product extensively with deionized water to remove the salt mixture.

- Further purify the polymer by washing with ethanol and acetone.
- Dry the final **Melem**-PDI polymer product in a vacuum oven at 80 °C.

B. Fabrication of Energy Storage Devices

1. Protocol for Fabrication of a Symmetric Supercapacitor with **Melem**-Based Electrodes

- Materials: **Melem**-based polymer (e.g., MAGA-derived carbon), Conductive carbon black (e.g., Super P), Polyvinylidene fluoride (PVDF) binder, N-Methyl-2-pyrrolidone (NMP) solvent, Current collectors (e.g., Nickel foam or Aluminum foil), Separator (e.g., Celgard), Electrolyte (e.g., 6 M KOH).
- Equipment: Mortar and pestle, Doctor blade, Vacuum oven, Coin cell crimper, Galvanostatic cyclers.
- Procedure:
 - Prepare the electrode slurry by mixing the **melem**-based polymer, conductive carbon black, and PVDF binder in a weight ratio of 80:10:10 in a mortar.
 - Add a few drops of NMP and grind the mixture to form a homogeneous slurry.
 - Coat the slurry onto the current collector using a doctor blade to a desired thickness.
 - Dry the coated electrodes in a vacuum oven at 120 °C for 12 hours.
 - Punch out circular electrodes of a specific diameter.
 - Assemble a symmetric supercapacitor in a coin cell inside a glovebox. The configuration should be: electrode, separator soaked in electrolyte, second electrode.
 - Crimp the coin cell to ensure it is properly sealed.
 - Perform electrochemical testing using a galvanostatic cycler.

2. Protocol for Fabrication of a Li-ion Coin Cell with a **Melem**-Based Cathode^{[1][8][9][10]}

- Materials: **Melem**-based polymer (e.g., **Melem**-PDI-CNT), Conductive carbon black, PVDF binder, NMP solvent, Aluminum foil (current collector), Lithium metal foil (anode), Separator, Electrolyte (e.g., 1 M LiPF₆ in a mixture of ethylene carbonate (EC) and dimethyl carbonate (DMC)).
- Equipment: Mortar and pestle, Doctor blade, Vacuum oven, Coin cell assembly kit, Glovebox.
- Procedure:
 - Prepare the cathode slurry as described in the supercapacitor fabrication protocol (Section III.B.1).
 - Cast the slurry onto aluminum foil and dry in a vacuum oven.
 - Punch out cathode discs of a specific diameter.
 - Inside an argon-filled glovebox, assemble a coin cell in the following order: cathode disc, separator, a few drops of electrolyte, lithium metal anode, spacer, and spring.
 - Seal the coin cell using a crimper.
 - Allow the cell to rest for several hours before electrochemical testing to ensure proper wetting of the electrode and separator.

IV. Mandatory Visualizations

A. Experimental Workflows

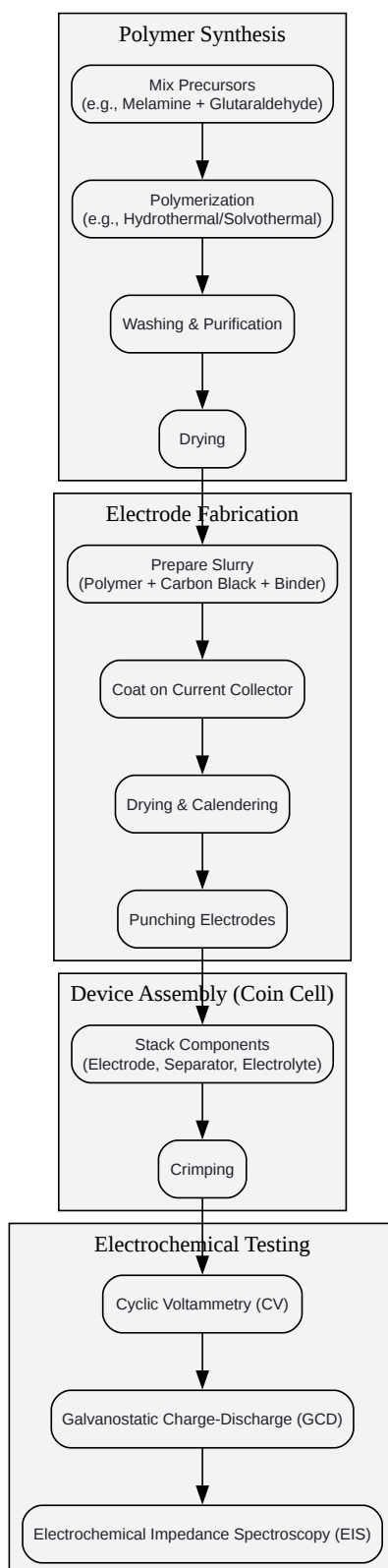

[Click to download full resolution via product page](#)

Caption: Workflow for Synthesis and Device Fabrication.

B. Electrochemical Characterization Logic

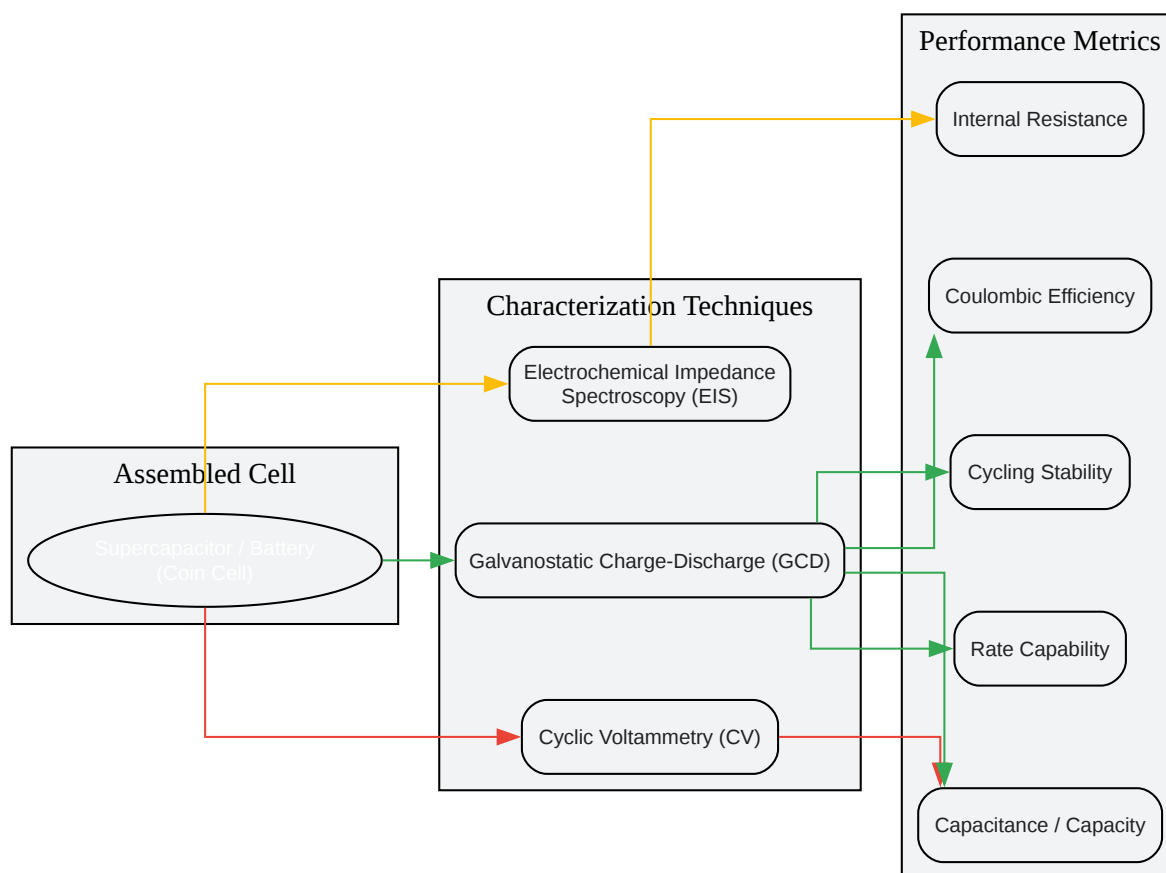

[Click to download full resolution via product page](#)

Caption: Electrochemical Characterization Workflow.

Need Custom Synthesis?

BenchChem offers custom synthesis for rare earth carbides and specific isotopic labeling.

Email: info@benchchem.com or [Request Quote Online](#).

References

- 1. nanomaterialpowder.com [nanomaterialpowder.com]
- 2. researchgate.net [researchgate.net]
- 3. Melamine-based metal-organic frameworks for high-performance supercapacitor applications - PubMed [pubmed.ncbi.nlm.nih.gov]
- 4. researchgate.net [researchgate.net]
- 5. researchgate.net [researchgate.net]
- 6. Novel safer phosphonate-based gel polymer electrolytes for sodium-ion batteries with excellent cycling performance - Journal of Materials Chemistry A (RSC Publishing) [pubs.rsc.org]
- 7. A P2-Na_{0.67}Co_{0.5}Mn_{0.5}O₂ cathode material with excellent rate capability and cycling stability for sodium ion batteries - Journal of Materials Chemistry A (RSC Publishing) [pubs.rsc.org]
- 8. How To Make Coin Cells - Landt Instruments [landtinst.com]
- 9. How to make a coin cell - Clean Energy Institute [cei.washington.edu]
- 10. Non-aqueous Electrode Processing and Construction of Lithium-ion Coin Cells - PMC [pmc.ncbi.nlm.nih.gov]
- To cite this document: BenchChem. [Application Notes and Protocols for Melem-Based Polymers in Energy Storage]. BenchChem, [2025]. [Online PDF]. Available at: [https://www.benchchem.com/product/b072624#melem-based-polymers-for-energy-storage-applications]

Disclaimer & Data Validity:

The information provided in this document is for Research Use Only (RUO) and is strictly not intended for diagnostic or therapeutic procedures. While BenchChem strives to provide accurate protocols, we make no warranties, express or implied, regarding the fitness of this product for every specific experimental setup.

Technical Support: The protocols provided are for reference purposes. Unsure if this reagent suits your experiment? [[Contact our Ph.D. Support Team for a compatibility check](#)]

Need Industrial/Bulk Grade? [Request Custom Synthesis Quote](#)

BenchChem

Our mission is to be the trusted global source of essential and advanced chemicals, empowering scientists and researchers to drive progress in science and industry.

Contact

Address: 3281 E Guasti Rd

Ontario, CA 91761, United States

Phone: (601) 213-4426

Email: info@benchchem.com