

Application Notes and Protocols for Measuring BPhBT Charge Carrier Mobility

Author: BenchChem Technical Support Team. **Date:** December 2025

Compound of Interest

Compound Name: BPhBT

Cat. No.: B1212908

[Get Quote](#)

For Researchers, Scientists, and Drug Development Professionals

This document provides detailed application notes and experimental protocols for measuring the charge carrier mobility of benzo[1,2-b:4,5-b']bis[1]benzothiophene (**BPhBT**) and its derivatives. Understanding charge carrier mobility is crucial for the development and optimization of organic electronic devices, including organic field-effect transistors (OFETs), organic photovoltaics (OPVs), and organic light-emitting diodes (OLEDs).

Introduction

BPhBT is a promising organic semiconductor material due to its rigid, planar molecular structure, which facilitates intermolecular charge transport. The charge carrier mobility (μ), a measure of how quickly an electron or hole can move through a material under the influence of an electric field, is a key parameter determining the performance of devices based on **BPhBT**. This document outlines three common experimental techniques for measuring charge carrier mobility: Time-of-Flight (TOF), Field-Effect Transistor (FET), and Space-Charge-Limited Current (SCLC).

General Experimental Workflow

The general workflow for determining the charge carrier mobility of **BPhBT** involves several key stages, from material synthesis and purification to device fabrication and electrical characterization. The choice of measurement technique depends on the specific research goals, available resources, and the form of the **BPhBT** material (e.g., single crystal, thin film).

General Workflow for BPhBT Mobility Measurement



[Click to download full resolution via product page](#)

Caption: General workflow for measuring **BPhBT** charge carrier mobility.

Data Presentation

While specific quantitative charge carrier mobility data for **BPhBT** is not widely available in the reviewed literature, the following table presents data for the closely related and well-studied dinaphtho[2,3-b:2',3'-f]thieno[3,2-b]thiophene (DNTT) and its derivatives, which share a similar fused thiophene-aromatic core. This data can serve as a valuable benchmark for expected mobility ranges in **BPhBT** systems.

Compound	Measurement Technique	Mobility (cm ² /Vs)	Substrate Temperature (°C)	Dielectric	Notes
DNTT	FET	2.5	90	Si/SiO ₂	Monosubstituted with branched alkyl group for solution processability. [2]
C ₁₀ -DNTT	FET	10.4	N/A	Flexible substrate	Layer-by-layer lamination process. [1]
S-DNTT	FET	2.1	N/A	Si/SiO ₂	S-shaped π -core derivative, solution processed. [1]
2,9-DPh-DNTT	FET	~3.5	N/A	Si/SiO ₂	Diphenyl-substituted DNTT, evaporated thin film. [3]
3,10-DPh-DNTT	FET	~3.5	N/A	Si/SiO ₂	Diphenyl-substituted DNTT, evaporated thin film. [3]
3,10-C ₁₀ -DNTT	FET	8.0	90	Si/SiO ₂	Vapor-processed thin film. [4]

Experimental Protocols

Field-Effect Transistor (FET) Measurement

The FET technique is the most common method for determining the charge carrier mobility in thin-film transistors. It measures the mobility in the direction parallel to the substrate surface.

Device Structure:

A typical bottom-gate, top-contact OFET structure is used for **BPhBT** mobility measurements.

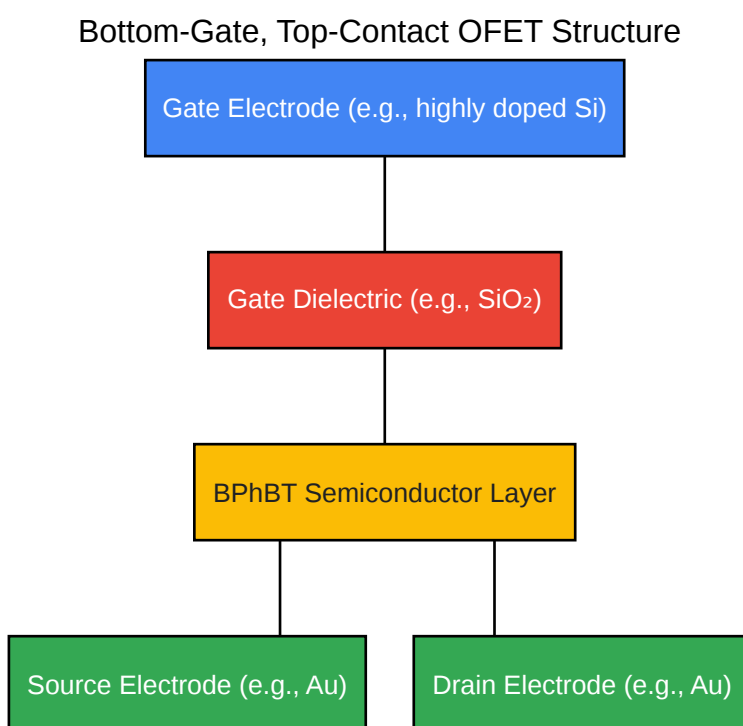

SCLC Device Structures for Hole- and Electron-Only Measurement

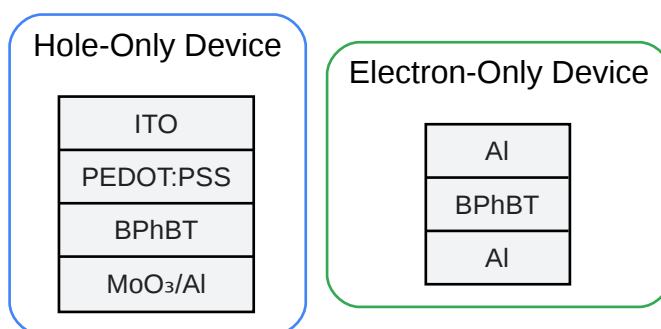

TOF Measurement Setup

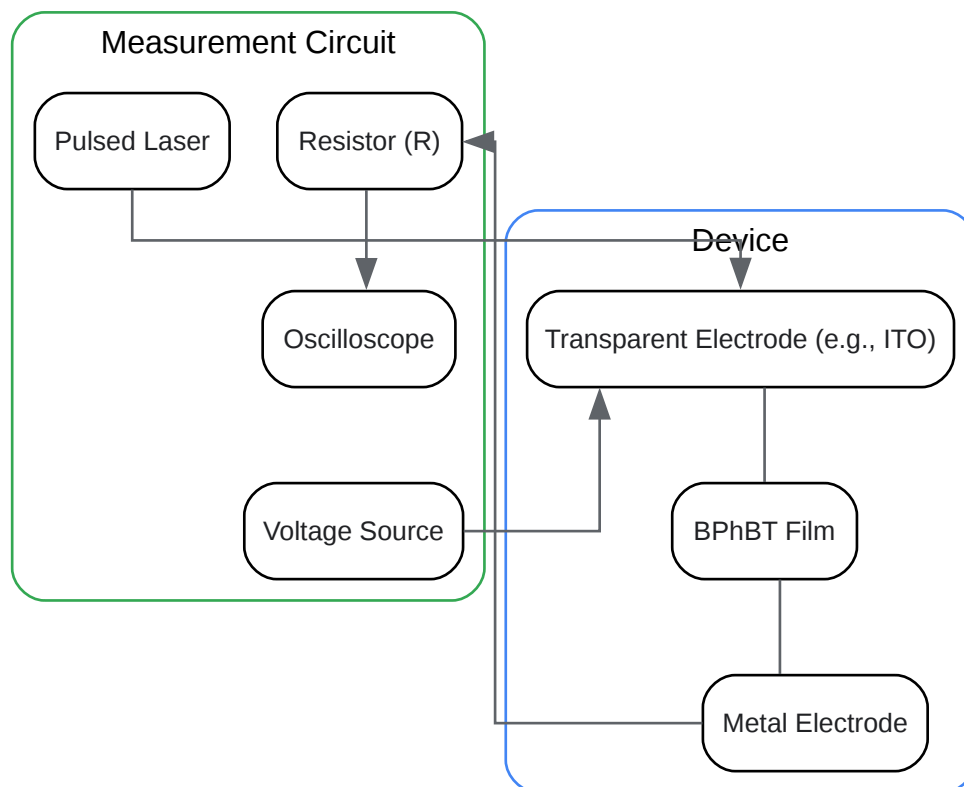

Logic for Selecting a Mobility Measurement Technique

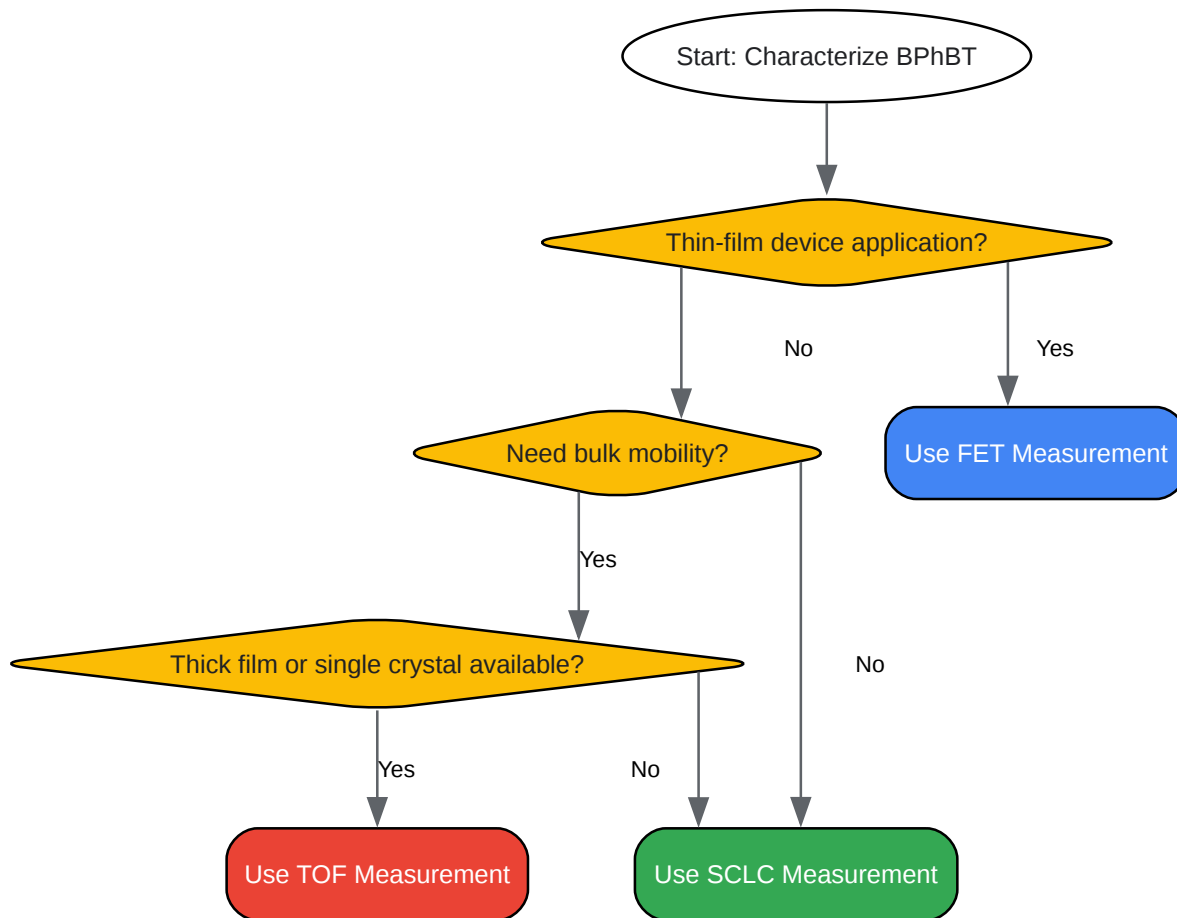

[Click to download full resolution via product page](#)

Need Custom Synthesis?

BenchChem offers custom synthesis for rare earth carbides and specific isotopic labeling.

Email: info@benchchem.com or [Request Quote Online](#).

References

- 1. [researchgate.net](#) [researchgate.net]
- 2. [pubs.acs.org](#) [pubs.acs.org]
- 3. [pubs.acs.org](#) [pubs.acs.org]
- 4. [researchgate.net](#) [researchgate.net]

- To cite this document: BenchChem. [Application Notes and Protocols for Measuring BPhBT Charge Carrier Mobility]. BenchChem, [2025]. [Online PDF]. Available at: [<https://www.benchchem.com/product/b1212908#experimental-setup-for-measuring-bphbt-charge-carrier-mobility>]

Disclaimer & Data Validity:

The information provided in this document is for Research Use Only (RUO) and is strictly not intended for diagnostic or therapeutic procedures. While BenchChem strives to provide accurate protocols, we make no warranties, express or implied, regarding the fitness of this product for every specific experimental setup.

Technical Support: The protocols provided are for reference purposes. Unsure if this reagent suits your experiment? [[Contact our Ph.D. Support Team for a compatibility check](#)]

Need Industrial/Bulk Grade? [Request Custom Synthesis Quote](#)

BenchChem

Our mission is to be the trusted global source of essential and advanced chemicals, empowering scientists and researchers to drive progress in science and industry.

Contact

Address: 3281 E Guasti Rd

Ontario, CA 91761, United States

Phone: (601) 213-4426

Email: info@benchchem.com