

# Application Notes and Protocols for EDTA-Mediated Detachment of Adherent Cells

**Author:** BenchChem Technical Support Team. **Date:** December 2025

## Compound of Interest

Compound Name: Ethylenediaminetetraacetic acid

Cat. No.: B1146802

[Get Quote](#)

For Researchers, Scientists, and Drug Development Professionals

## Introduction

The detachment of adherent cells from culture substrates is a fundamental and routine procedure in cell biology research, drug discovery, and the manufacturing of cell-based therapies. While enzymatic methods, such as trypsinization, are widely used, they can suffer from drawbacks including damage to cell surface proteins and reduced cell viability.

**Ethylenediaminetetraacetic acid** (EDTA), a chelating agent, offers a gentle and effective non-enzymatic alternative for detaching adherent cells. By sequestering divalent cations essential for cell adhesion, EDTA disrupts the interactions between cells and the extracellular matrix, as well as intercellular connections, leading to cell detachment.[1][2][3] This document provides detailed application notes, protocols, and quantitative data on the use of EDTA for this purpose.

## Mechanism of Action

EDTA's function in cell detachment is rooted in its ability to chelate divalent cations, primarily calcium ( $\text{Ca}^{2+}$ ) and magnesium ( $\text{Mg}^{2+}$ ).[1][3][4] These ions are crucial cofactors for various cell adhesion molecules (CAMs), including cadherins and integrins, which mediate cell-cell and cell-substrate attachments, respectively.[4][5]

- **Cadherins:** These transmembrane proteins are responsible for calcium-dependent cell-cell adhesion. The extracellular domains of cadherins require  $\text{Ca}^{2+}$  to maintain a rigid conformation necessary for homophilic binding to cadherins on adjacent cells.[4]

- Integrins: This family of transmembrane receptors mediates the attachment of cells to the extracellular matrix (ECM). The binding of integrins to ECM components like fibronectin and laminin is dependent on the presence of divalent cations such as  $\text{Ca}^{2+}$  and  $\text{Mg}^{2+}$ . [1]

By binding to these essential cations, EDTA reduces their availability, leading to a conformational change in cadherins and integrins. [4] This weakens their adhesive interactions, causing the cells to detach from the culture surface and from each other. [1][4]

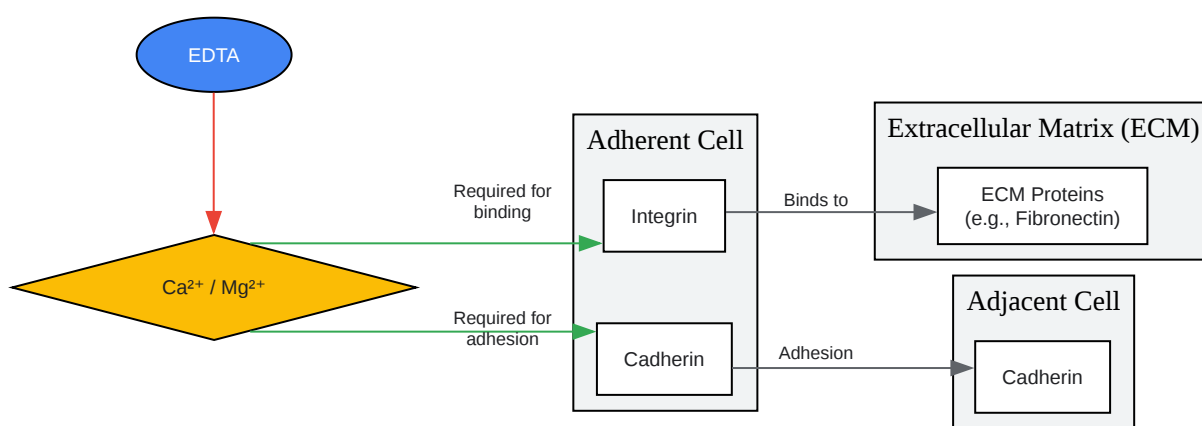

[Click to download full resolution via product page](#)

Caption: Mechanism of EDTA-mediated cell detachment.

## Advantages of Using EDTA

The use of EDTA for cell detachment offers several advantages over enzymatic methods:

- Preservation of Cell Surface Proteins: As a non-enzymatic agent, EDTA does not cleave cell surface proteins, which is particularly important for applications like flow cytometry, immunophenotyping, and studies involving cell surface receptors. [6][7][8]
- Gentle on Cells: EDTA is generally less harsh than proteases, which can improve cell viability and reduce cellular stress. [2]

- **Simplicity and Cost-Effectiveness:** EDTA solutions are simple to prepare, stable, and inexpensive.[5]
- **Compatibility with High-Throughput Screening:** The direct addition of EDTA to the culture medium can simplify workflows for high-throughput flow cytometry by eliminating washing and centrifugation steps.[5][6]

## Quantitative Data Summary

The optimal concentration and incubation time for EDTA-mediated cell detachment can vary depending on the cell line and its degree of adherence. The following tables summarize quantitative data from various studies.

Table 1: EDTA Concentration and Detachment Time for Various Cell Lines

Cell Line	EDTA Concentration	Incubation Time	Notes	Reference
MCF-7	10 mM	> 45 min	Required pipetting for complete detachment.	[5]
DU145	12.5 - 17.5 mM	15 - 45 min	Optimized for a two-step protocol without pipetting.	[5]
HepG2	12.5 - 17.5 mM	15 - 45 min	Optimized for a two-step protocol without pipetting.	[5]
GIMEN	3 mM	45 min	Optimized for high-throughput flow cytometry in 384-well plates.	[6]
HT-29	Not specified	Not specified	Enhanced detachment when combined with oxaliplatin.	[9]
General Use	10 mM	5 min	Recommended starting point for optimization.	[10]
General Use	1 - 10 mM	Not specified	Effective concentration range for metalloprotease inhibition.	[11]

Table 2: Comparison of EDTA-based and Trypsin-EDTA Detachment

Parameter	EDTA	Trypsin-EDTA	Reference
Mechanism	Chelates divalent cations	Enzymatic digestion and chelation	[1][4]
Effect on Surface Proteins	Minimal, preserves epitopes	Can cleave surface proteins	[6][7][12]
Cell Viability	Generally high	Can be reduced with over-exposure	[5][12]
Typical Concentration	0.5 - 10 mM	0.05% - 0.25% Trypsin with 0.53 mM EDTA	[5][13]

## Experimental Protocols

### Protocol 1: Standard EDTA Detachment for Passaging Adherent Cells

This protocol is suitable for routine passaging of most adherent cell lines.

Materials:

- Phosphate-Buffered Saline (PBS), Ca<sup>2+</sup>/Mg<sup>2+</sup>-free
- EDTA solution (0.5 M stock solution, pH 8.0)
- Cell culture medium, pre-warmed to 37°C
- Sterile serological pipettes
- Sterile centrifuge tubes

Procedure:

- Aspirate the cell culture medium from the flask or dish.

- Wash the cell monolayer once with pre-warmed,  $\text{Ca}^{2+}/\text{Mg}^{2+}$ -free PBS to remove any residual medium and serum.
- Prepare the working EDTA solution by diluting the 0.5 M stock in  $\text{Ca}^{2+}/\text{Mg}^{2+}$ -free PBS to a final concentration of 0.5-1.0 mM. For a T-75 flask, 3-5 mL is typically sufficient.
- Add the working EDTA solution to the cell monolayer, ensuring the entire surface is covered.
- Incubate the vessel at 37°C for 5-15 minutes. The incubation time should be optimized for the specific cell line. Monitor the cells under a microscope; detached cells will appear rounded and begin to float.
- Gently tap the side of the culture vessel to dislodge the remaining attached cells.
- Add an equal volume of pre-warmed complete culture medium to the vessel to inactivate the EDTA by providing an excess of divalent cations.
- Pipette the cell suspension up and down gently to create a single-cell suspension.
- Transfer the cell suspension to a sterile centrifuge tube.
- Centrifuge the cells at 100-300 x g for 5 minutes.
- Aspirate the supernatant and resuspend the cell pellet in fresh, pre-warmed culture medium for cell counting and replating.

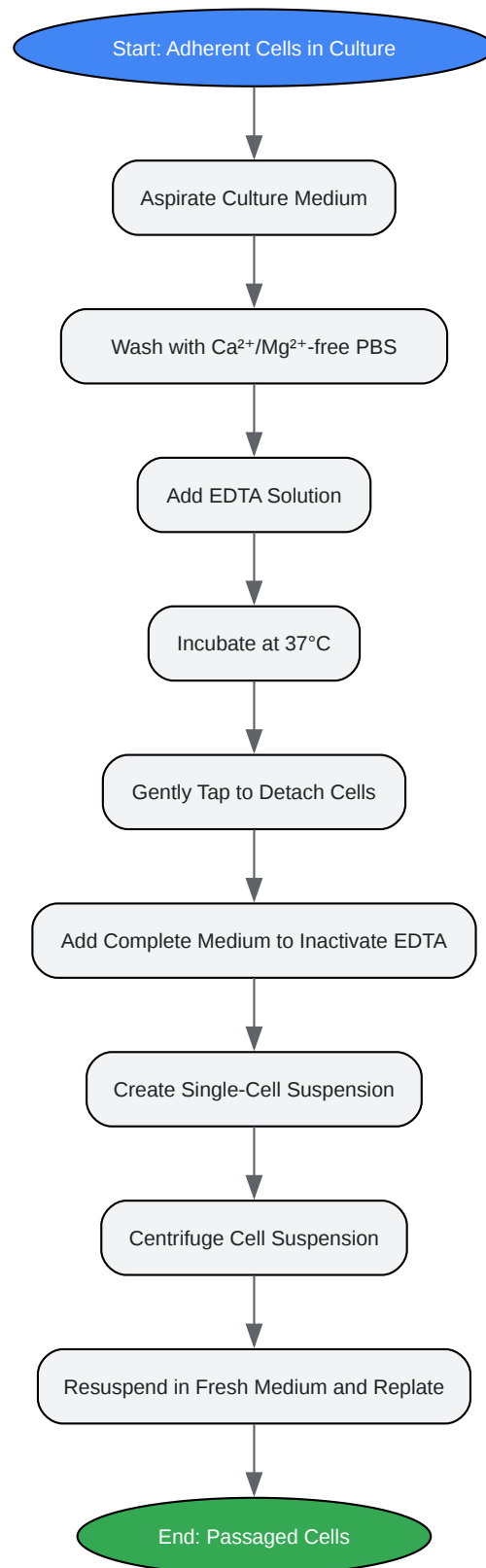

[Click to download full resolution via product page](#)

Caption: Standard workflow for EDTA-based cell detachment.

## Protocol 2: "No-Wash" EDTA Detachment for High-Throughput Flow Cytometry

This protocol is adapted for high-throughput applications where minimizing cell loss and processing time is critical.[5][6]

### Materials:

- Adherent cells cultured in 96- or 384-well plates
- EDTA stock solution (e.g., 250 mM, pH 6.1-6.5)[5]
- Staining solution (e.g., antibodies, viability dyes in serum-free medium)

### Procedure:

- Culture adherent cells in microplates to the desired confluency.
- Prepare the working EDTA solution by diluting the stock solution in deionized water to the optimized concentration (e.g., 15 mM for a final concentration of 3 mM when added to the well).[6]
- Directly add the working EDTA solution to each well containing culture medium. For a 384-well plate with 40  $\mu$ L of medium, adding 5  $\mu$ L of 15 mM EDTA will result in a final concentration of approximately 3 mM.[6]
- Incubate the plate at 37°C for an optimized duration (e.g., 45 minutes).[6] Gentle shaking on an orbital shaker for 30 seconds before and after incubation can aid detachment.[6]
- Add the staining solution directly to the wells.
- Incubate as required for the specific stain.
- Analyze the cells directly on a flow cytometer equipped with a high-throughput sampler.

## Signaling Considerations



While EDTA's primary mechanism is the disruption of cation-dependent adhesion, the process of cell detachment itself can initiate intracellular signaling cascades. The detachment from the ECM can lead to a form of apoptosis known as anoikis in some cell types. This is triggered by the loss of survival signals normally transduced by integrins. However, for routine passaging, the time course of EDTA treatment is typically short enough to avoid significant induction of apoptosis. It is important to note that prolonged incubation with high concentrations of EDTA can lead to decreased cell viability.[5]

## Troubleshooting

- Incomplete Detachment:
  - Increase the EDTA concentration.
  - Increase the incubation time.
  - Ensure the PBS used for washing and preparing the EDTA solution is completely free of  $\text{Ca}^{2+}$  and  $\text{Mg}^{2+}$ .
  - Gently tap the culture vessel or use gentle pipetting to aid detachment.
- Low Cell Viability:
  - Decrease the EDTA concentration.
  - Reduce the incubation time.
  - Handle the cells gently during pipetting to minimize mechanical stress.
  - Ensure the pH of the EDTA solution is within the optimal range (e.g., 6.1-7.4).[5]
- Cell Clumping:
  - Pipette the cell suspension gently but thoroughly to break up clumps.
  - Consider adding a low concentration of DNase I (if  $\text{Mg}^{2+}$  is present in the final buffer) to digest DNA released from any lysed cells, which can cause clumping.[14] Note that EDTA can inhibit DNase I activity.

## Conclusion

EDTA provides a reliable and gentle method for detaching adherent cells, offering significant advantages over enzymatic digestion, particularly when the integrity of cell surface proteins is crucial. By optimizing the EDTA concentration and incubation time for specific cell lines, researchers can achieve efficient cell detachment while maintaining high cell viability and functionality. The protocols provided herein serve as a starting point for the successful implementation of EDTA-based cell detachment in a variety of research and drug development applications.

### *Need Custom Synthesis?*

*BenchChem offers custom synthesis for rare earth carbides and specific isotopic labeling.*

*Email: [info@benchchem.com](mailto:info@benchchem.com) or [Request Quote Online](#).*

## References

- 1. [purmabiologics.com](http://purmabiologics.com) [[purmabiologics.com](http://purmabiologics.com)]
- 2. Cell Dissociation and Trypsin for Cell Culture | Thermo Fisher Scientific - US [[thermofisher.com](http://thermofisher.com)]
- 3. [researchgate.net](http://researchgate.net) [[researchgate.net](http://researchgate.net)]
- 4. [youtube.com](http://youtube.com) [[youtube.com](http://youtube.com)]
- 5. [tandfonline.com](http://tandfonline.com) [[tandfonline.com](http://tandfonline.com)]
- 6. A “No-Touch” Antibody-Staining Method of Adherent Cells for High-Throughput Flow Cytometry in 384-Well Microplate Format for Cell-Based Drug Library Screening - PMC [[pmc.ncbi.nlm.nih.gov](http://pmc.ncbi.nlm.nih.gov)]
- 7. [different-methods-of-detaching-adherent-cells-and-their-effects-on-the-cell-surface-expression-of-fas-receptor-and-fas-ligand](#) - Ask this paper | Bohrium [[bohrium.com](http://bohrium.com)]
- 8. [researchgate.net](http://researchgate.net) [[researchgate.net](http://researchgate.net)]
- 9. Evaluation of Cell-detaching Effect of EDTA in Combination with Oxaliplatin for a Possible Application in HIPEC After Cytoreductive Surgery: A Preliminary in-vitro Study - PubMed [[pubmed.ncbi.nlm.nih.gov](http://pubmed.ncbi.nlm.nih.gov)]
- 10. [biology.stackexchange.com](http://biology.stackexchange.com) [[biology.stackexchange.com](http://biology.stackexchange.com)]

- 11. [sigmaaldrich.com](https://www.sigmaaldrich.com) [[sigmaaldrich.com](https://www.sigmaaldrich.com)]
- 12. [researchgate.net](https://www.researchgate.net) [[researchgate.net](https://www.researchgate.net)]
- 13. [caissonlabs.com](https://www.caissonlabs.com) [[caissonlabs.com](https://www.caissonlabs.com)]
- 14. [flowcyt.rutgers.edu](https://flowcyt.rutgers.edu) [[flowcyt.rutgers.edu](https://flowcyt.rutgers.edu)]
- To cite this document: BenchChem. [Application Notes and Protocols for EDTA-Mediated Detachment of Adherent Cells]. BenchChem, [2025]. [Online PDF]. Available at: [<https://www.benchchem.com/product/b1146802#use-of-edta-for-detaching-adherent-cells-in-culture>]

---

### Disclaimer & Data Validity:

The information provided in this document is for Research Use Only (RUO) and is strictly not intended for diagnostic or therapeutic procedures. While BenchChem strives to provide accurate protocols, we make no warranties, express or implied, regarding the fitness of this product for every specific experimental setup.

**Technical Support:** The protocols provided are for reference purposes. Unsure if this reagent suits your experiment? [[Contact our Ph.D. Support Team for a compatibility check](#)]

**Need Industrial/Bulk Grade?** [Request Custom Synthesis Quote](#)

## BenchChem

Our mission is to be the trusted global source of essential and advanced chemicals, empowering scientists and researchers to drive progress in science and industry.

### Contact

Address: 3281 E Guasti Rd  
Ontario, CA 91761, United States  
Phone: (601) 213-4426  
Email: [info@benchchem.com](mailto:info@benchchem.com)