

Application Notes and Protocols for Checkerboard Assay with AcrB-IN-2

Author: BenchChem Technical Support Team. **Date:** December 2025

Compound of Interest

Compound Name: *AcrB-IN-2*

Cat. No.: *B12409446*

[Get Quote](#)

For Researchers, Scientists, and Drug Development Professionals

These application notes provide a detailed protocol for performing a checkerboard assay to evaluate the synergistic activity of the AcrB efflux pump inhibitor, **AcrB-IN-2**, with various antibiotics against multidrug-resistant bacteria.

Introduction

The AcrB protein is a key component of the AcrAB-TolC multidrug efflux pump in Gram-negative bacteria, which actively transports a broad range of antibiotics out of the cell, contributing significantly to antibiotic resistance.[1][2][3][4] **AcrB-IN-2** is an inhibitor of the AcrB efflux pump and has been shown to potentiate the activity of several antibiotics.[5] The checkerboard assay is a common in vitro method used to assess the interaction between two antimicrobial agents, allowing for the determination of synergistic, additive, indifferent, or antagonistic effects.[6][7][8] This is achieved by measuring the minimal inhibitory concentration (MIC) of each agent alone and in combination. The interaction is quantified by the Fractional Inhibitory Concentration (FIC) index.[6][7]

Principle of the Checkerboard Assay

The checkerboard assay involves a two-dimensional titration of two compounds in a microtiter plate. Serial dilutions of one compound (e.g., an antibiotic) are made along the x-axis, and serial dilutions of the second compound (e.g., **AcrB-IN-2**) are made along the y-axis. Each well is then inoculated with a standardized bacterial suspension. After incubation, the wells are

examined for bacterial growth to determine the MIC of each compound alone and in combination. The FIC index is then calculated to determine the nature of the interaction.

Data Presentation

The synergistic activity of **AcrB-IN-2** with various antibiotics can be summarized in the following tables. The data presented here is based on reported findings for **AcrB-IN-2** and serves as an example.[5] Researchers should generate their own data for specific bacterial strains and antibiotics.

Table 1: Synergistic Activity of **AcrB-IN-2** with Antibiotics

Antibiotic	Bacterial Strain	AcrB-IN-2 Concentration (µg/mL)	Fold Reduction in Antibiotic MIC	FIC Index	Interpretation
Minocycline (MIN)	Multidrug-resistant E. coli	64	4	≤ 0.5	Synergy
Erythromycin (ERY)	Multidrug-resistant E. coli	8 - 128	Not specified	≤ 0.5	Synergy
Levofloxacin (LEV)	Multidrug-resistant E. coli	8 - 128	Not specified	≤ 0.5	Synergy

Table 2: Interpretation of Fractional Inhibitory Concentration (FIC) Index

FIC Index	Interpretation
≤ 0.5	Synergy
> 0.5 to 4.0	Indifference or Additive
> 4.0	Antagonism

Experimental Protocols

Materials

- 96-well microtiter plates
- **AcrB-IN-2**
- Antibiotic(s) of interest
- Bacterial strain(s) of interest (e.g., multidrug-resistant Escherichia coli)
- Cation-adjusted Mueller-Hinton Broth (CAMHB)
- Sterile pipette tips and multichannel pipettes
- Incubator (37°C)
- Microplate reader (optional, for OD measurements)
- 0.5 McFarland turbidity standard

Protocol

1. Preparation of Reagents:

- **AcrB-IN-2** Stock Solution: Prepare a stock solution of **AcrB-IN-2** in a suitable solvent (e.g., DMSO) at a high concentration (e.g., 10 mg/mL). Further dilute in CAMHB to the desired starting concentration for the assay.
- Antibiotic Stock Solution: Prepare a stock solution of the antibiotic in its recommended solvent and dilute it in CAMHB to the desired starting concentration.
- Bacterial Inoculum: Culture the bacterial strain overnight on an appropriate agar plate. The following day, suspend several colonies in sterile saline to match the turbidity of a 0.5 McFarland standard. This corresponds to approximately 1.5×10^8 CFU/mL. Dilute this suspension in CAMHB to achieve a final concentration of 5×10^5 CFU/mL in each well of the microtiter plate.

2. Checkerboard Plate Setup:

A standard 96-well plate setup for a checkerboard assay is depicted below. This setup allows for the testing of a range of concentrations for both the antibiotic and **AcrB-IN-2**.

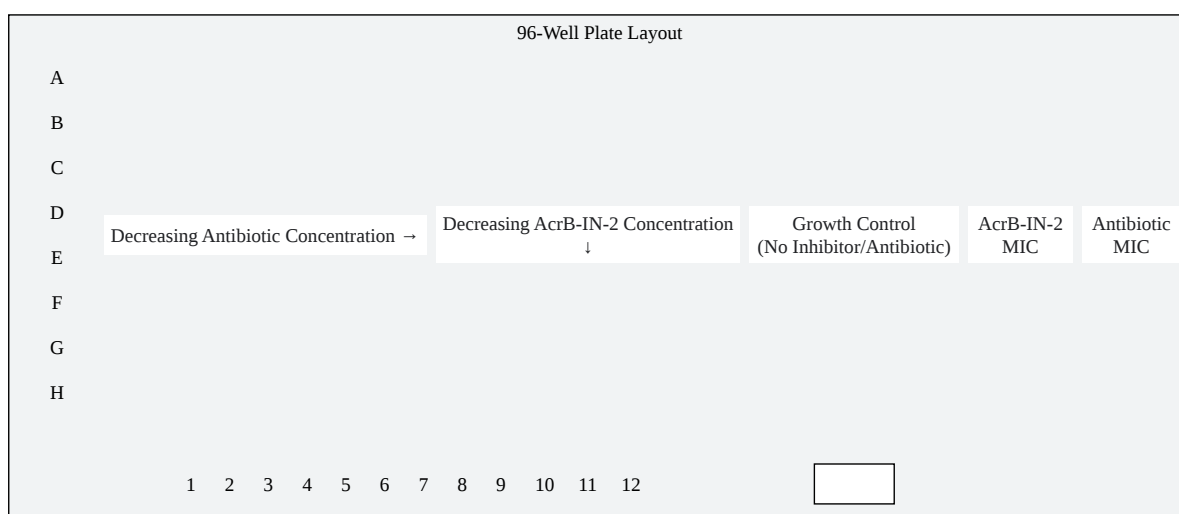

[Click to download full resolution via product page](#)

Caption: General layout of a 96-well plate for a checkerboard assay.

3. Dilution Procedure:

- Plate Preparation: Add 50 μ L of CAMHB to all wells of a 96-well plate.
- Antibiotic Dilution:

- Add 50 μ L of the highest concentration of the antibiotic to column 1.
- Perform serial two-fold dilutions by transferring 50 μ L from column 1 to column 2, mixing, and continuing this process across to column 10. Discard 50 μ L from column 10. Column 11 will serve as the **AcrB-IN-2** only control. Column 12 will be the growth control.
- **AcrB-IN-2** Dilution:
 - Add 50 μ L of the highest concentration of **AcrB-IN-2** to row A (columns 1-11).
 - Perform serial two-fold dilutions by transferring 50 μ L from row A to row B, mixing, and continuing this process down to row G. Discard 50 μ L from row G. Row H will serve as the antibiotic only control.
- Final Inoculation: Add 100 μ L of the prepared bacterial inoculum (at 5×10^5 CFU/mL) to all wells except for a sterility control well (e.g., H12, which should contain only broth). The final volume in each well will be 200 μ L.

4. Incubation:

- Incubate the plate at 37°C for 18-24 hours.

5. Reading the Results:

- Visually inspect the wells for turbidity. The MIC is defined as the lowest concentration of the drug(s) that completely inhibits visible bacterial growth.
- Alternatively, the optical density (OD) at 600 nm can be measured using a microplate reader.

6. Calculation of the FIC Index:

The FIC index is calculated for each well that shows no bacterial growth.

- FIC of Antibiotic (FIC_A): (MIC of antibiotic in combination) / (MIC of antibiotic alone)
- FIC of **AcrB-IN-2** (FIC_B): (MIC of **AcrB-IN-2** in combination) / (MIC of **AcrB-IN-2** alone)
- FIC Index: FIC_A + FIC_B

The lowest FIC index value determines the nature of the interaction.

Mandatory Visualizations

Experimental Workflow

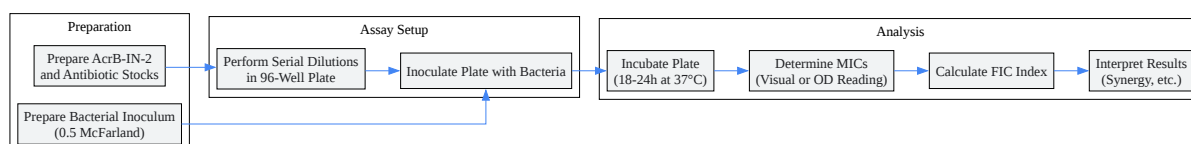

[Click to download full resolution via product page](#)

Caption: Workflow for the checkerboard assay with **AcrB-IN-2**.

AcrB Efflux Pump Inhibition Pathway

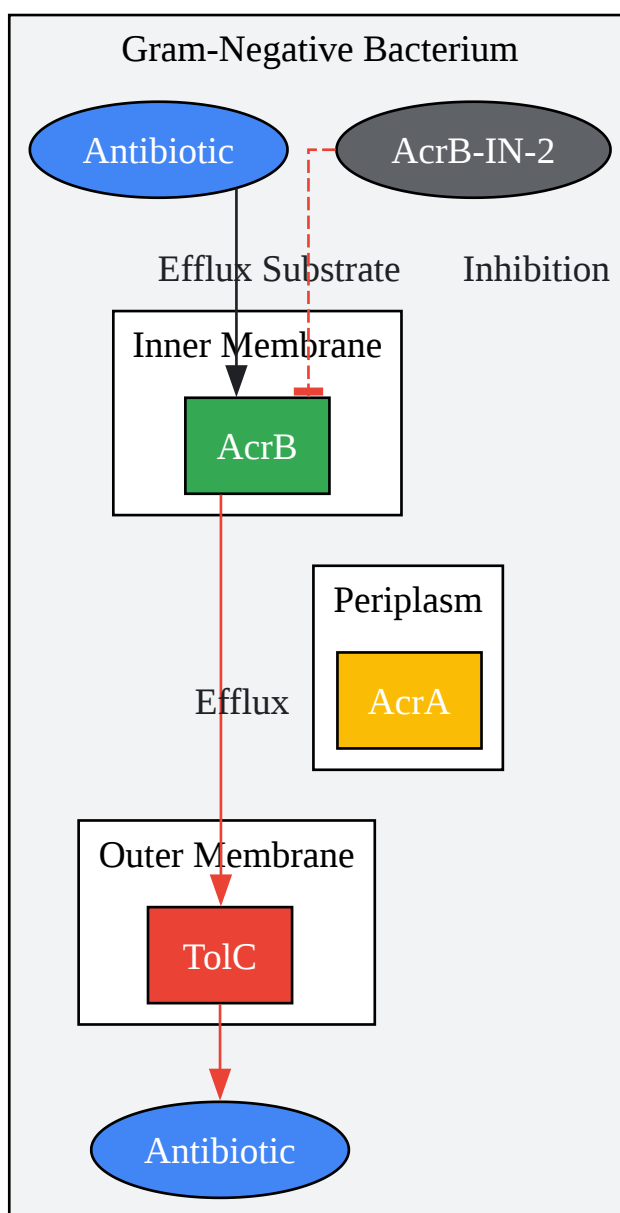

[Click to download full resolution via product page](#)

Caption: Inhibition of the AcrAB-TolC efflux pump by **AcrB-IN-2**.

Need Custom Synthesis?

BenchChem offers custom synthesis for rare earth carbides and specific isotopic labeling.

Email: info@benchchem.com or [Request Quote Online](#).

References

- 1. crystal.ku.edu [crystal.ku.edu]
- 2. AcrB Multidrug Efflux Pump of Escherichia coli: Composite Substrate-Binding Cavity of Exceptional Flexibility Generates Its Extremely Wide Substrate Specificity - PMC [pmc.ncbi.nlm.nih.gov]
- 3. Crystal structure of the multidrug efflux transporter AcrB at 3.1 Å resolution reveals the N-terminal region with conserved amino acids - PMC [pmc.ncbi.nlm.nih.gov]
- 4. AcrAB–TolC, a major efflux pump in Gram negative bacteria: toward understanding its operation mechanism - PMC [pmc.ncbi.nlm.nih.gov]
- 5. medchemexpress.com [medchemexpress.com]
- 6. emerypharma.com [emerypharma.com]
- 7. Antimicrobial Synergy Testing/Checkerboard Assay - Creative Diagnostics [antiviral.creative-diagnostics.com]
- 8. When Does 2 Plus 2 Equal 5? A Review of Antimicrobial Synergy Testing - PMC [pmc.ncbi.nlm.nih.gov]
- To cite this document: BenchChem. [Application Notes and Protocols for Checkerboard Assay with AcrB-IN-2]. BenchChem, [2025]. [Online PDF]. Available at: [https://www.benchchem.com/product/b12409446#how-to-perform-a-checkerboard-assay-with-acrb-in-2]

Disclaimer & Data Validity:

The information provided in this document is for Research Use Only (RUO) and is strictly not intended for diagnostic or therapeutic procedures. While BenchChem strives to provide accurate protocols, we make no warranties, express or implied, regarding the fitness of this product for every specific experimental setup.

Technical Support: The protocols provided are for reference purposes. Unsure if this reagent suits your experiment? [[Contact our Ph.D. Support Team for a compatibility check](#)]

Need Industrial/Bulk Grade? [Request Custom Synthesis Quote](#)

BenchChem

Our mission is to be the trusted global source of essential and advanced chemicals, empowering scientists and researchers to drive progress in science and industry.

Contact

Address: 3281 E Guasti Rd

Ontario, CA 91761, United States

Phone: (601) 213-4426

Email: info@benchchem.com