

# Application Notes and Protocols for CGP 36742 in In Vitro Slice Electrophysiology

**Author:** BenchChem Technical Support Team. **Date:** December 2025

## Compound of Interest

Compound Name: CGP 36742

Cat. No.: B1668497

[Get Quote](#)

For Researchers, Scientists, and Drug Development Professionals

These application notes provide a comprehensive guide for the use of **CGP 36742**, a selective GABA-B receptor antagonist, in in vitro slice electrophysiology experiments. The information is compiled to assist in the accurate and effective application of this compound for studying neuronal circuits and synaptic plasticity.

## Introduction

**CGP 36742**, also known as (3-aminopropyl)-n-butylphosphinic acid, is a potent and selective antagonist of GABA-B receptors. It is a valuable pharmacological tool for investigating the role of GABA-B receptor-mediated signaling in various physiological and pathological processes in the central nervous system. In in vitro slice electrophysiology, **CGP 36742** is commonly used to block both presynaptic and postsynaptic GABA-B receptors, thereby modulating neuronal excitability and synaptic transmission.

## Data Presentation: Recommended Concentrations

The effective concentration of **CGP 36742** can vary depending on the specific research question, the brain region under investigation, and the type of neuron being studied. The following table summarizes recommended concentrations from various studies.

Application	Concentration Range	Brain Region/Cell Type	Key Findings
Blockade of late inhibitory postsynaptic potentials (IPSPs)	100 $\mu$ M	Rat dorsolateral septal neurons	Reduced the amplitude of the late, GABA-B receptor-mediated IPSP by 76 $\pm$ 8%. <a href="#">[1]</a>
Enhancement of somatostatin release	< 1 $\mu$ M (EC <sub>50</sub> = 0.2 $\mu$ M)	Rat hippocampal synaptosomes	Increased the basal release of [ <sup>125</sup> I]somatostatin. <a href="#">[2]</a> <a href="#">[3]</a>
Potentialiation of postsynaptic somatostatin effects	5 $\mu$ M	Rat hippocampal CA1 pyramidal cells	Enhanced the postsynaptic effects of somatostatin. <a href="#">[3]</a>
Prevention of NMDA receptor antagonism by kynurenate	1 $\mu$ M	Rat brain slices	Prevented kynurenate from antagonizing NMDA-induced noradrenaline release. <a href="#">[4]</a>
Increase of somatostatin-like immunoreactivity release	1 $\mu$ M	Rat hippocampal slices	Increased the release of somatostatin-like immunoreactivity when exposed to NMDA. <a href="#">[4]</a>
General GABA-B receptor antagonism (IC <sub>50</sub> )	36 $\mu$ M	Not specified	The half maximal inhibitory concentration for GABA-B receptor binding.

## Experimental Protocols

### Preparation of CGP 36742 Stock Solution

#### Materials:

- **CGP 36742** powder
- Sterile deionized water or artificial cerebrospinal fluid (aCSF)
- Vortex mixer
- Sterile microcentrifuge tubes
- 0.22  $\mu\text{m}$  syringe filter

#### Procedure:

- Calculate the required amount of **CGP 36742** powder to prepare a stock solution of a desired concentration (e.g., 10 mM or 100 mM).
- Weigh the **CGP 36742** powder accurately and place it in a sterile microcentrifuge tube.
- Add the appropriate volume of sterile deionized water or aCSF to the tube.
- Vortex the solution until the **CGP 36742** is completely dissolved.
- If using water as the solvent, sterile filter the stock solution using a 0.22  $\mu\text{m}$  syringe filter before use.
- Aliquot the stock solution into smaller volumes to avoid repeated freeze-thaw cycles.
- Store the stock solution at  $-20^{\circ}\text{C}$  for short-term storage (up to 1 month) or  $-80^{\circ}\text{C}$  for long-term storage (up to 6 months).

## Acute Brain Slice Preparation

This protocol is a general guideline and may need to be optimized for specific experimental needs. The N-methyl-D-glucamine (NMDG) protective recovery method is recommended for enhanced neuronal viability.

#### Materials:

- Rodent (e.g., mouse or rat)
- Anesthesia (e.g., isoflurane, ketamine/xylazine)
- Dissection tools (scissors, forceps, scalpel)
- Vibrating microtome (vibratome)
- NMDG-aCSF cutting solution (chilled and carbogenated)
- Standard aCSF for recording (warmed to physiological temperature and carbogenated)
- Recovery chamber

#### Procedure:

- Anesthetize the animal deeply according to approved institutional protocols.
- Perform transcardial perfusion with ice-cold, carbogenated (95% O<sub>2</sub> / 5% CO<sub>2</sub>) NMDG-aCSF to clear the blood and cool the brain.
- Rapidly decapitate the animal and dissect the brain, placing it immediately into the ice-cold NMDG-aCSF.
- Mount the brain onto the vibratome stage and prepare coronal or sagittal slices of the desired thickness (typically 250-350 μm).
- Transfer the slices to a recovery chamber containing NMDG-aCSF at 32-34°C for a brief recovery period (e.g., 10-15 minutes).
- Transfer the slices to a holding chamber containing standard aCSF at room temperature and allow them to equilibrate for at least 1 hour before recording.

## In Vitro Slice Electrophysiology and CGP 36742 Application

#### Materials:

- Patch-clamp rig (microscope, micromanipulators, amplifier, data acquisition system)
- Recording chamber continuously perfused with carbogenated aCSF
- Borosilicate glass capillaries for patch pipettes
- Pipette puller
- Intracellular solution
- **CGP 36742** working solution (diluted from stock in aCSF)

Procedure:

- Transfer a brain slice to the recording chamber on the microscope stage and secure it with a slice anchor.
- Continuously perfuse the slice with warmed (30-32°C), carbogenated aCSF at a flow rate of 2-3 ml/min.
- Identify the neuron of interest using differential interference contrast (DIC) or infrared (IR) microscopy.
- Pull a patch pipette with a resistance of 3-7 M $\Omega$  and fill it with the appropriate intracellular solution.
- Approach the target neuron and establish a gigaohm seal (>1 G $\Omega$ ).
- Rupture the membrane to obtain the whole-cell configuration.
- Record baseline synaptic activity or membrane properties.
- To apply **CGP 36742**, switch the perfusion from the control aCSF to the aCSF containing the desired final concentration of **CGP 36742**. This is known as bath application.
- Allow sufficient time for the drug to equilibrate in the slice (typically 5-10 minutes) before recording the effects.

- To wash out the drug, switch the perfusion back to the control aCSF.

## Mandatory Visualizations

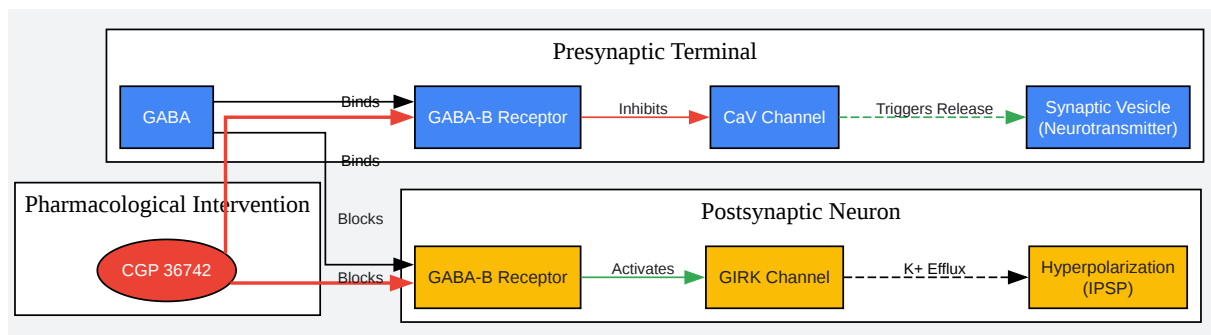

[Click to download full resolution via product page](#)

Caption: GABA-B Receptor Signaling and Antagonism by **CGP 36742**.

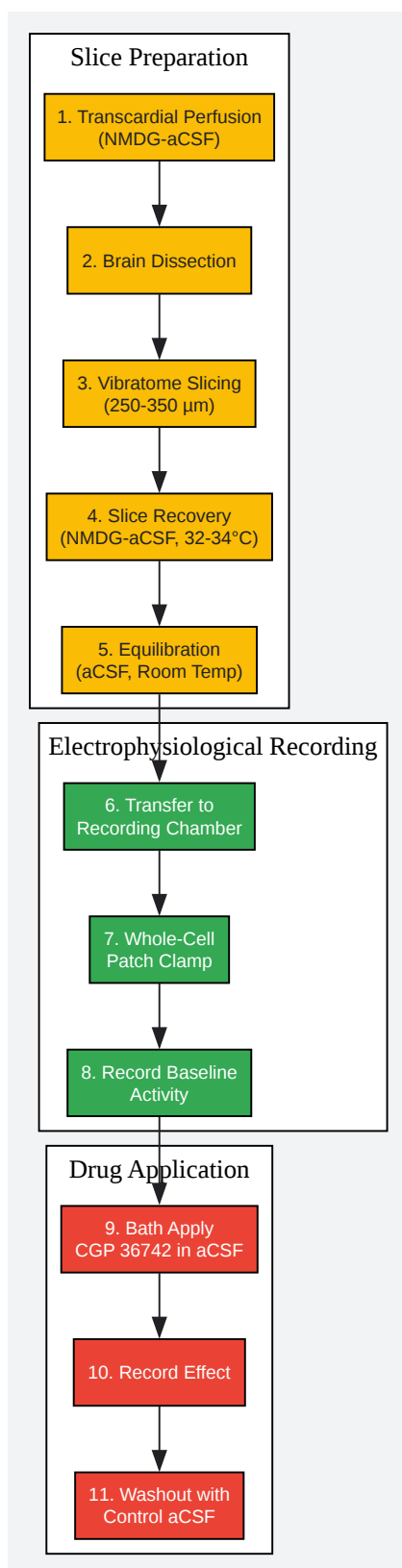

[Click to download full resolution via product page](#)

Caption: Experimental Workflow for In Vitro Slice Electrophysiology with **CGP 36742**.

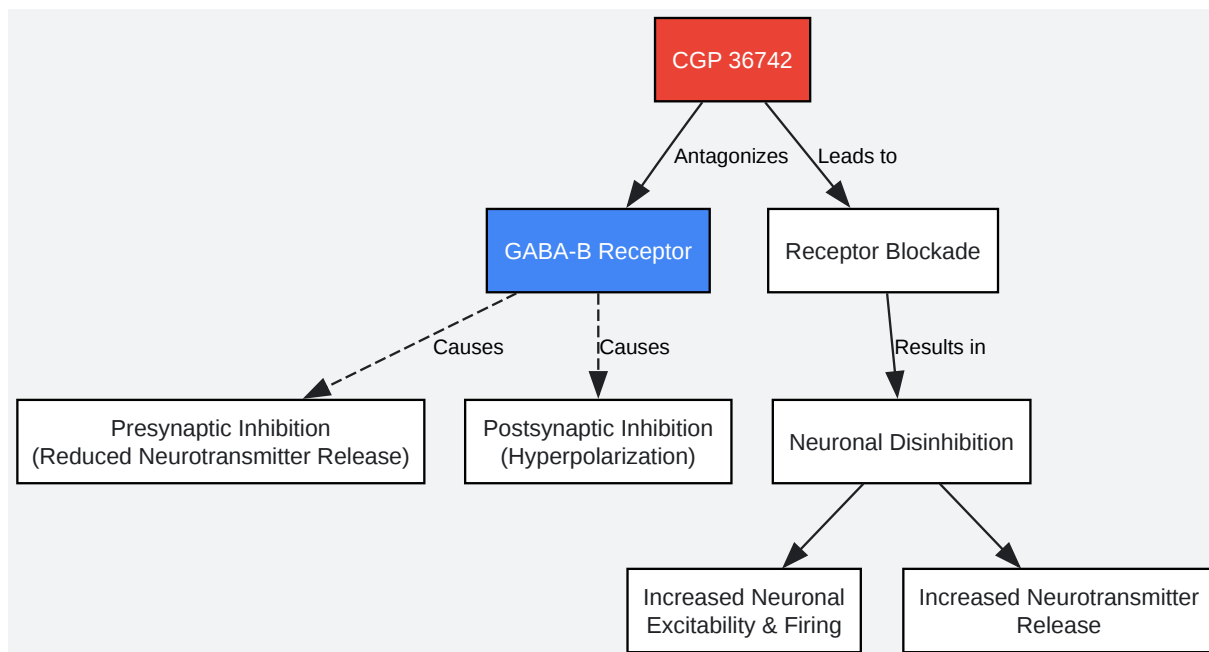

[Click to download full resolution via product page](#)

Caption: Logical Relationship of **CGP 36742** Action.

### Need Custom Synthesis?

BenchChem offers custom synthesis for rare earth carbides and specific isotopic labeling.

Email: [info@benchchem.com](mailto:info@benchchem.com) or [Request Quote Online](#).

## References

- 1. Local Application of Drugs to Study Nicotinic Acetylcholine Receptor Function in Mouse Brain Slices - PMC [pmc.ncbi.nlm.nih.gov]
- 2. precisionary.com [precisionary.com]
- 3. providence.elsevierpure.com [providence.elsevierpure.com]
- 4. researchgate.net [researchgate.net]
- To cite this document: BenchChem. [Application Notes and Protocols for CGP 36742 in In Vitro Slice Electrophysiology]. BenchChem, [2025]. [Online PDF]. Available at:



[<https://www.benchchem.com/product/b1668497#recommended-cgp-36742-concentration-for-in-vitro-slice-electrophysiology>]

---

**Disclaimer & Data Validity:**

The information provided in this document is for Research Use Only (RUO) and is strictly not intended for diagnostic or therapeutic procedures. While BenchChem strives to provide accurate protocols, we make no warranties, express or implied, regarding the fitness of this product for every specific experimental setup.

**Technical Support:** The protocols provided are for reference purposes. Unsure if this reagent suits your experiment? [[Contact our Ph.D. Support Team for a compatibility check](#)]

**Need Industrial/Bulk Grade?** [Request Custom Synthesis Quote](#)

## BenchChem

Our mission is to be the trusted global source of essential and advanced chemicals, empowering scientists and researchers to drive progress in science and industry.

### Contact

Address: 3281 E Guasti Rd  
Ontario, CA 91761, United States  
Phone: (601) 213-4426  
Email: [info@benchchem.com](mailto:info@benchchem.com)