

Application Notes and Protocols for Baricitinib Phosphate Administration in Animal Models

Author: BenchChem Technical Support Team. **Date:** December 2025

Compound of Interest

Compound Name: *Baricitinib phosphate*

Cat. No.: *B560045*

[Get Quote](#)

For Researchers, Scientists, and Drug Development Professionals

Introduction

Baricitinib, a potent and selective inhibitor of Janus kinase (JAK) 1 and JAK2, is an orally bioavailable therapeutic agent approved for several inflammatory and autoimmune diseases.[1][2] The JAK-STAT (Signal Transducer and Activator of Transcription) signaling pathway is a critical regulator of cytokine signaling, playing a pivotal role in immune responses and inflammation.[3][4] By inhibiting JAK1 and JAK2, baricitinib effectively modulates the signaling of numerous pro-inflammatory cytokines, including interleukin-6 (IL-6) and IL-23, making it a valuable tool for preclinical research in various animal models of disease.[4][5] These application notes provide detailed protocols and summarized data for the administration of baricitinib in common animal models of systemic lupus erythematosus, rheumatoid arthritis, and hemorrhagic shock, among others.

Mechanism of Action: Inhibition of the JAK/STAT Pathway

Cytokines and growth factors binding to their specific receptors on the cell surface trigger the activation of associated JAKs.[5] Activated JAKs then phosphorylate the receptor, creating docking sites for STAT proteins. Subsequently, STATs are phosphorylated, leading to their dimerization, translocation to the nucleus, and initiation of target gene transcription, which drives inflammatory processes.[3][4] Baricitinib exerts its therapeutic effect by binding to the

ATP-binding pocket of JAK1 and JAK2, preventing the phosphorylation and activation of STATs, thereby interrupting this signaling cascade.[2][5]

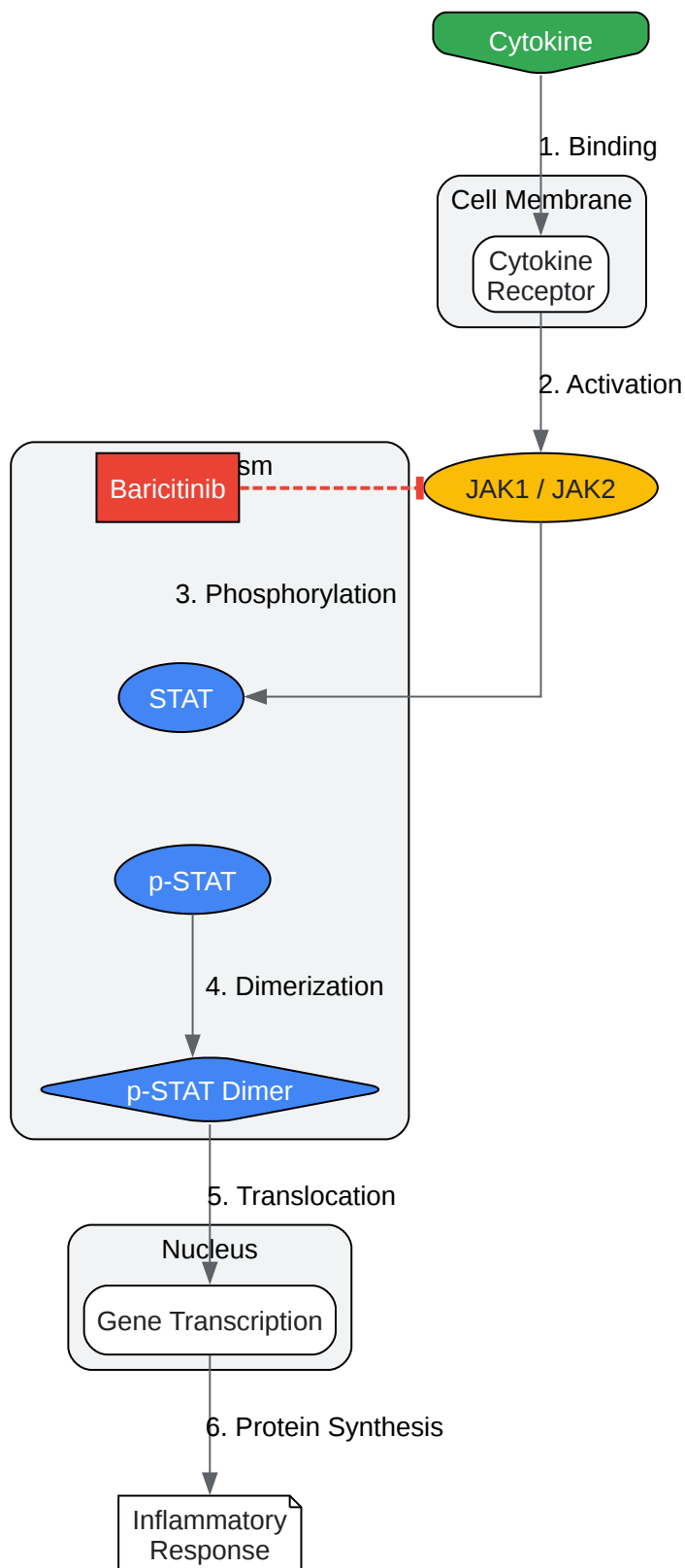

[Click to download full resolution via product page](#)

Caption: Baricitinib inhibits JAK1/JAK2, blocking STAT phosphorylation and downstream gene transcription.

Experimental Protocols

Protocol 1: Murine Model of Systemic Lupus Erythematosus (SLE)

This protocol describes the use of baricitinib in the MRL/Mp-Faslpr (MRL/lpr) mouse model, which spontaneously develops a lupus-like autoimmune disease.[6][7]

- Objective: To evaluate the efficacy of baricitinib in suppressing autoimmune phenotypes, particularly renal inflammation, in a lupus-prone mouse model.[6][8]
- Animal Model: 8-week-old female MRL/lpr mice.[6]
- Materials:
 - Baricitinib powder (e.g., MyBioSource).[7]
 - Vehicle: 0.5% Methyl cellulose in sterile water.[7]
 - Oral gavage needles.
- Procedure:
 - Acclimatize 8-week-old MRL/lpr mice for one week prior to the start of the experiment.
 - Randomly assign mice (n=8 per group) to a vehicle control group or a baricitinib treatment group.[6][9]
 - Prepare the baricitinib dosing solution by suspending the powder in 0.5% methyl cellulose.
 - Administer baricitinib at a dose of 10 mg/kg or an equivalent volume of vehicle via oral gavage.[7][9]
 - Dosing should be performed twice daily for a total of 8 weeks.[7][9]

- Monitor body weight and general health status weekly.
- At 16 weeks of age, euthanize the mice for endpoint analysis.[6][9]
- Collect blood for serological analysis (e.g., autoantibodies, cytokines) and tissues (spleen, lymph nodes, kidneys) for flow cytometry and histopathology.[6][7]

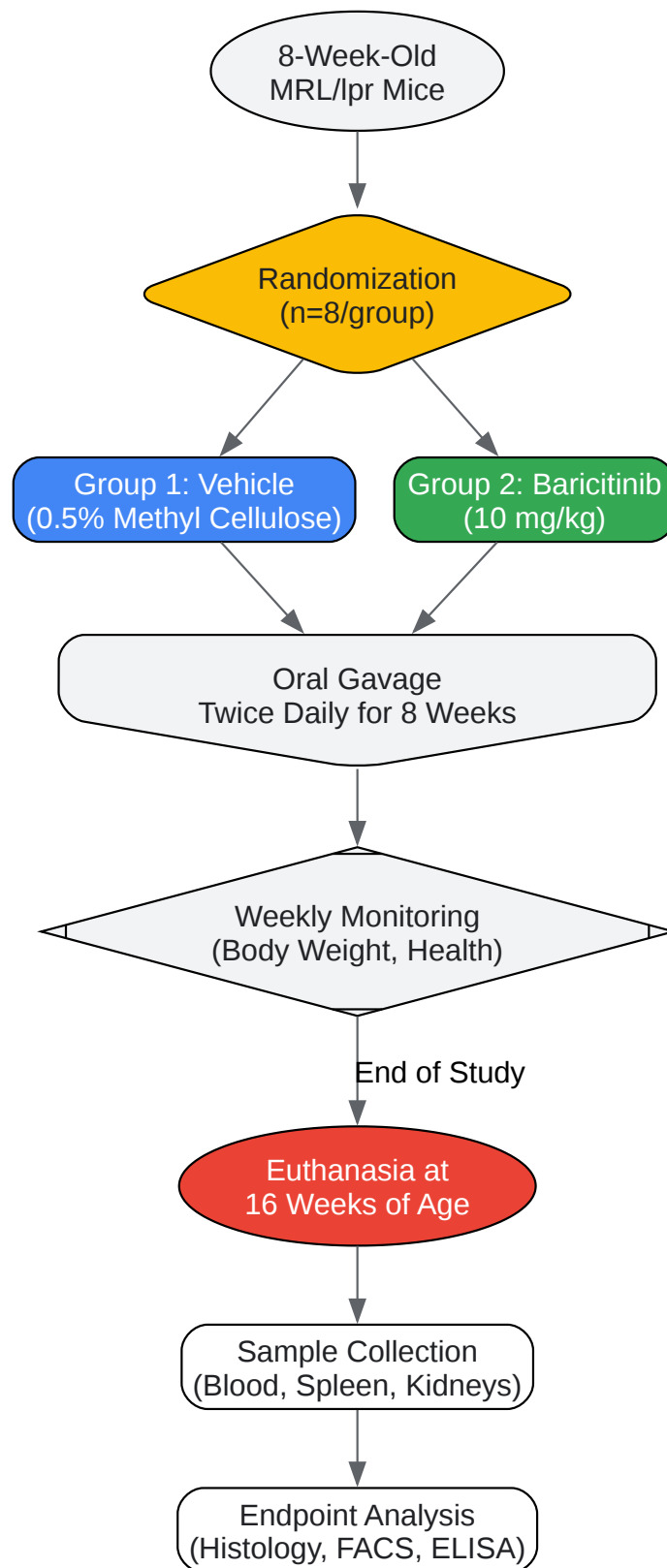

[Click to download full resolution via product page](#)

Caption: Experimental workflow for evaluating baricitinib in a murine SLE model.

Protocol 2: Rat Model of Hemorrhagic Shock (HS)

This protocol outlines the use of baricitinib to study its protective effects against multiple organ dysfunction following trauma and hemorrhage.

- Objective: To determine if baricitinib administration attenuates HS-associated organ injury by inhibiting the JAK/STAT pathway.[3]
- Animal Model: Male Wistar rats.
- Procedure:
 - Induce hemorrhagic shock in anesthetized rats through controlled blood withdrawal to achieve a target mean arterial pressure.
 - Following the shock period, resuscitate the animals with lactated Ringer's solution.
 - Administer baricitinib or vehicle intravenously or intraperitoneally post-resuscitation. (Note: The specific dose and timing should be optimized based on preliminary studies, as literature varies).
 - Monitor physiological parameters throughout the experiment.
 - At the study endpoint (e.g., 2-4 hours post-resuscitation), collect blood and tissue samples (liver, kidney) for analysis.[3]
 - Analyze plasma for markers of organ damage (e.g., ALT, creatinine) and tissues for activation of the JAK/STAT pathway (e.g., Western blot for p-JAK2 and p-STAT3).[3]

Protocol 3: Pharmacokinetic (PK) Analysis in Rats

This protocol provides a method for determining the plasma concentration profile of baricitinib following oral administration.

- Objective: To quantify the pharmacokinetic parameters of baricitinib in rats.
- Animal Model: Female Sprague-Dawley or Wistar rats.[10][11]

- Procedure:
 - Fast rats overnight prior to dosing but allow free access to water.
 - Administer a single dose of 10 mg/kg baricitinib by oral gavage at a volume of 10 mL/kg. [\[10\]](#)[\[11\]](#)
 - Collect blood samples (approx. 0.2 mL) into EDTA-containing tubes at specified time points. A sparse sampling design can be used:
 - Rat subset 1: 0 (predose), 2, 8, and 24 hours post-dose. [\[10\]](#)[\[11\]](#)
 - Rat subset 2: 1, 4, and 12 hours post-dose. [\[10\]](#)[\[11\]](#)
 - Immediately after collection, centrifuge the blood samples to separate plasma.
 - Store plasma samples at -80°C until analysis.
 - Quantify baricitinib concentrations in plasma using a validated LC/MS/MS (Liquid Chromatography-Tandem Mass Spectrometry) method. [\[10\]](#)[\[11\]](#)

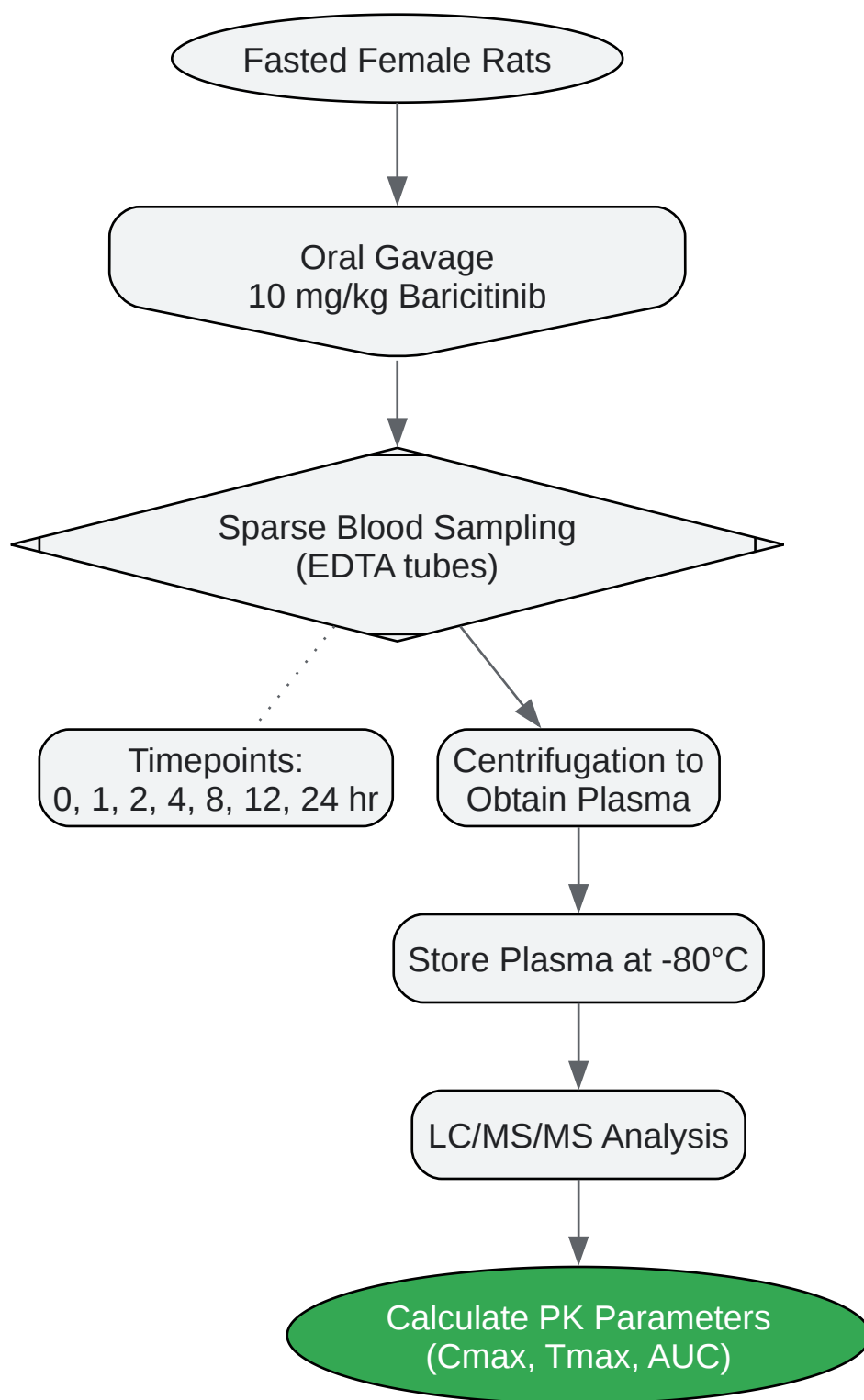

[Click to download full resolution via product page](#)

Need Custom Synthesis?

BenchChem offers custom synthesis for rare earth carbides and specific isotopic labeling.

Email: info@benchchem.com or [Request Quote Online](#).

References

- 1. Baricitinib phosphate (LY3009104, INCB028050, Olumiant) | JAK1/2 inhibitor | CAS 1187595-84-1 | arthritis | COVID-19 | alopecia areata| InvivoChem [[invivochem.com](https://www.invivochem.com)]
- 2. [qrheumatol.com](https://www.qrheumatol.com) [[qrheumatol.com](https://www.qrheumatol.com)]
- 3. Inhibition of the JAK/STAT Pathway With Baricitinib Reduces the Multiple Organ Dysfunction Caused by Hemorrhagic Shock in Rats - PMC [[pmc.ncbi.nlm.nih.gov](https://pubmed.ncbi.nlm.nih.gov)]
- 4. Frontiers | Baricitinib Ameliorates Experimental Autoimmune Encephalomyelitis by Modulating the Janus Kinase/Signal Transducer and Activator of Transcription Signaling Pathway [[frontiersin.org](https://www.frontiersin.org)]
- 5. Baricitinib in rheumatoid arthritis: evidence-to-date and clinical potential - PMC [[pmc.ncbi.nlm.nih.gov](https://pubmed.ncbi.nlm.nih.gov)]
- 6. Frontiers | Baricitinib Attenuates Autoimmune Phenotype and Podocyte Injury in a Murine Model of Systemic Lupus Erythematosus [[frontiersin.org](https://www.frontiersin.org)]
- 7. Baricitinib Attenuates Autoimmune Phenotype and Podocyte Injury in a Murine Model of Systemic Lupus Erythematosus - PMC [[pmc.ncbi.nlm.nih.gov](https://pubmed.ncbi.nlm.nih.gov)]
- 8. Baricitinib Attenuates Autoimmune Phenotype and Podocyte Injury in a Murine Model of Systemic Lupus Erythematosus - PubMed [pubmed.ncbi.nlm.nih.gov]
- 9. [researchgate.net](https://www.researchgate.net) [[researchgate.net](https://www.researchgate.net)]
- 10. Baricitinib phosphate|JAK 1 inhibitor|COVID-19|SARS-COV-2 [[dcchemicals.com](https://www.dcchemicals.com)]
- 11. [file.medchemexpress.com](https://www.file.medchemexpress.com) [[file.medchemexpress.com](https://www.file.medchemexpress.com)]
- To cite this document: BenchChem. [Application Notes and Protocols for Baricitinib Phosphate Administration in Animal Models]. BenchChem, [2025]. [Online PDF]. Available at: [<https://www.benchchem.com/product/b560045#baricitinib-phosphate-administration-in-animal-models>]

Disclaimer & Data Validity:

The information provided in this document is for Research Use Only (RUO) and is strictly not intended for diagnostic or therapeutic procedures. While BenchChem strives to provide accurate protocols, we make no warranties, express or implied, regarding the fitness of this product for every specific experimental setup.

Technical Support: The protocols provided are for reference purposes. Unsure if this reagent suits your experiment? [[Contact our Ph.D. Support Team for a compatibility check](#)]

Need Industrial/Bulk Grade? [Request Custom Synthesis Quote](#)

BenchChem

Our mission is to be the trusted global source of essential and advanced chemicals, empowering scientists and researchers to drive progress in science and industry.

Contact

Address: 3281 E Guasti Rd
Ontario, CA 91761, United States
Phone: (601) 213-4426
Email: info@benchchem.com