

# Application Notes and Protocols for BMS-690154 in Xenograft Models

**Author:** BenchChem Technical Support Team. **Date:** December 2025

## Compound of Interest

Compound Name: BMS-690154

Cat. No.: B1149919

[Get Quote](#)

For Researchers, Scientists, and Drug Development Professionals

## Introduction

**BMS-690154** is a potent, orally available small molecule inhibitor targeting multiple receptor tyrosine kinases. It functions as a pan-HER/VEGFR inhibitor, effectively blocking signaling through the human epidermal growth factor receptor (HER) family (EGFR/HER1, HER2, HER4) and vascular endothelial growth factor receptors (VEGFRs). The active form of the drug, BMS-690514, has demonstrated significant anti-proliferative and anti-angiogenic activity in a variety of preclinical cancer models. These characteristics make **BMS-690154** a compelling candidate for in vivo studies utilizing xenograft models to assess its therapeutic potential against various tumor types.

This document provides detailed application notes and protocols for the use of **BMS-690154** in xenograft models, including data presentation, experimental procedures, and visual diagrams of its mechanism of action and experimental workflow.

## Data Presentation

### In Vitro Cellular Activity of BMS-690514

Cell Line	Tumor Type	Target Receptor Status	IC50 (nM)
PC9	Non-Small Cell Lung	EGFR (exon 19 deletion)	~3
NCI-H1975	Non-Small Cell Lung	EGFR (L858R/T790M)	~200
BT-474	Breast	HER2 amplified	~10
KPL-4	Breast	HER2 amplified	~15
NCI-N87	Gastric	HER2 amplified	~20
HUVEC	Endothelial	VEGFR2	~5

## In Vivo Efficacy of BMS-690514 in Xenograft Models

Xenograft Model	Tumor Type	Dosing Schedule	Route of Administration	Tumor Growth Inhibition (TGI) / Effect	Reference
PC9	Non-Small Cell Lung	>3 mg/kg, once daily	Oral gavage	Tumor regression	[1]
NCI-H1975	Non-Small Cell Lung	30 mg/kg/day for 5 days	Oral gavage	Significant tumor growth delay	[2]
H1299	Non-Small Cell Lung	30 mg/kg/day for 3 days	Oral gavage	Decreased tumor vascularization	[2]
HER2-amplified gastric	Gastric	7.5 mg/kg, once daily	Oral gavage	Significant tumor growth inhibition	[1]

## Experimental Protocols

### General Xenograft Model Establishment

- Cell Culture: Culture the desired human cancer cell line (e.g., PC9, NCI-H1975) in appropriate media and conditions until a sufficient number of cells are obtained.
- Cell Preparation: Harvest cells using trypsin-EDTA, wash with sterile PBS, and resuspend in a 1:1 mixture of serum-free medium and Matrigel at a final concentration of  $1 \times 10^7$  cells/mL.
- Animal Model: Use immunocompromised mice (e.g., athymic nude or NOD/SCID), typically 6-8 weeks old.
- Tumor Implantation: Subcutaneously inject 100-200  $\mu$ L of the cell suspension into the flank of each mouse.
- Tumor Growth Monitoring: Monitor tumor growth by measuring tumor volume with calipers 2-3 times per week. The tumor volume can be calculated using the formula:  $(\text{Length} \times \text{Width}^2) / 2$ .
- Randomization: When tumors reach a mean volume of 100-200  $\text{mm}^3$ , randomize the mice into treatment and control groups.

### Preparation and Administration of BMS-690154 (as BMS-690514)

- Drug Formulation:
  - For oral administration, BMS-690514 can be formulated in a vehicle such as 0.5% methylcellulose in water.
  - Prepare the formulation fresh daily.
  - The concentration of the drug solution should be calculated based on the desired dose and the average weight of the mice.
- Dosing:

- A common dosing schedule is once daily oral gavage.
- Effective doses in preclinical models have ranged from 3 mg/kg to 30 mg/kg.[1][2] The maximum tolerated dose in mice has been reported to be 90 mg/kg.[1]
- The duration of treatment can vary from a few days to several weeks, depending on the experimental design.
- Administration:
  - Administer the drug solution or vehicle control to the mice using a gavage needle.
  - Monitor the animals for any signs of toxicity, such as weight loss, lethargy, or ruffled fur.

## Efficacy Evaluation

- Tumor Measurement: Continue to measure tumor volume throughout the study.
- Body Weight: Monitor the body weight of the mice as an indicator of toxicity.
- Endpoint: The study can be terminated when tumors in the control group reach a predetermined size, or after a specific treatment duration.
- Data Analysis: Analyze the tumor growth data to determine the tumor growth inhibition (TGI). TGI can be calculated as:  $\%TGI = (1 - (\text{Mean tumor volume of treated group} / \text{Mean tumor volume of control group})) \times 100$ .
- Immunohistochemistry: At the end of the study, tumors can be excised, fixed in formalin, and embedded in paraffin for immunohistochemical analysis of biomarkers such as Ki-67 (proliferation) and CD31 (microvessel density).

## Mandatory Visualizations

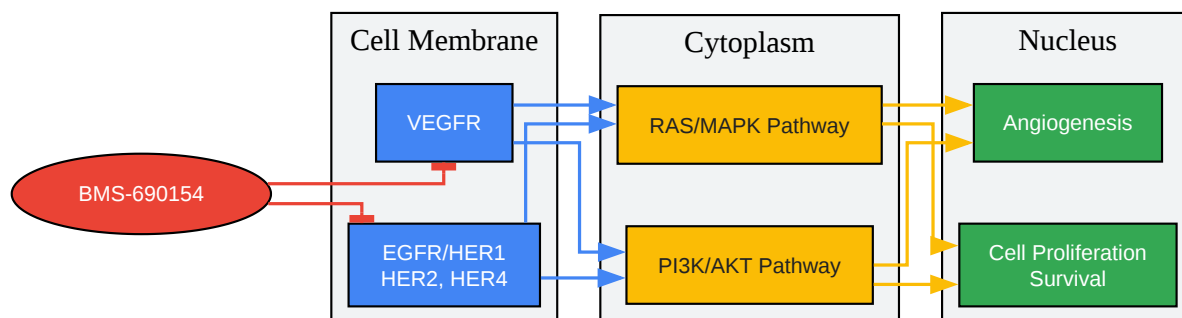

[Click to download full resolution via product page](#)

Caption: **BMS-690154** inhibits HER and VEGFR signaling pathways.

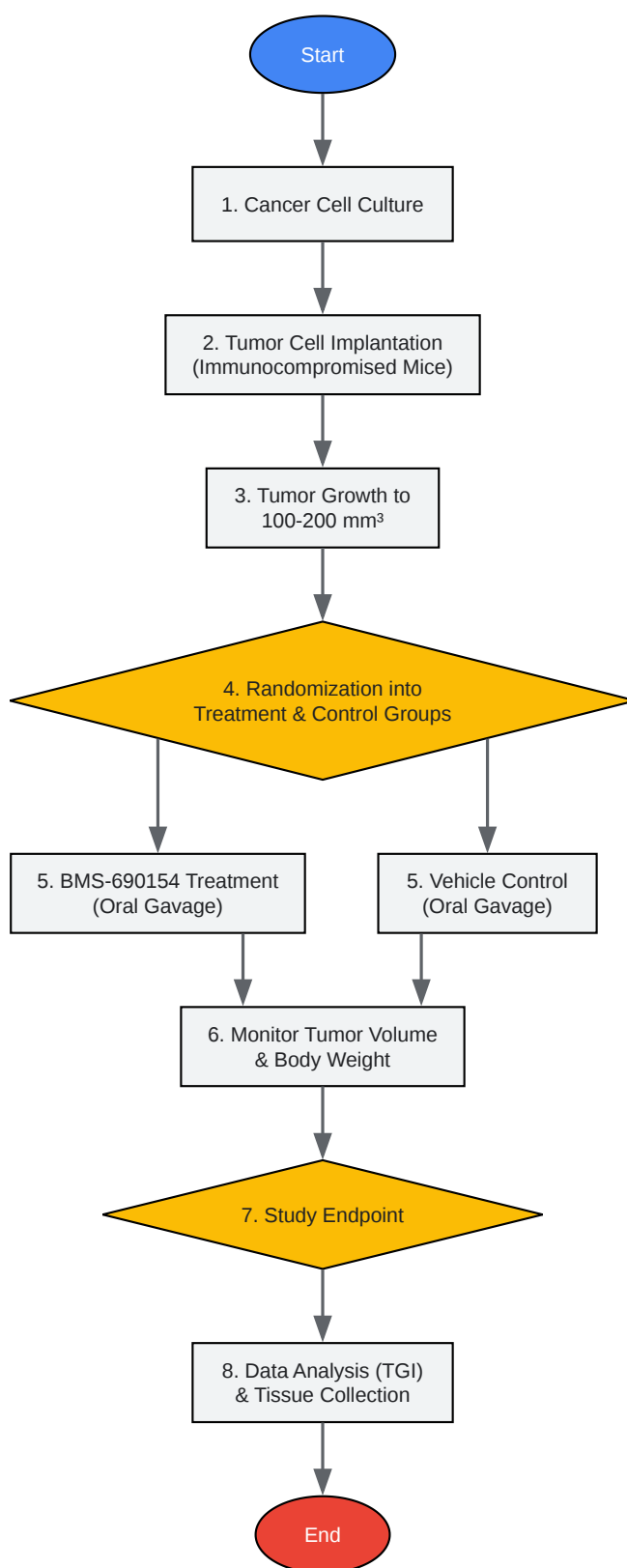

[Click to download full resolution via product page](#)

Caption: Experimental workflow for a **BMS-690154** xenograft study.

**Need Custom Synthesis?**

BenchChem offers custom synthesis for rare earth carbides and specific isotopic labeling.

Email: [info@benchchem.com](mailto:info@benchchem.com) or [Request Quote Online](#).

## References

- 1. aacrjournals.org [aacrjournals.org]
- 2. BMS-690514, a VEGFR and EGFR tyrosine kinase inhibitor, shows anti-tumoural activity on non-small-cell lung cancer xenografts and induces sequence-dependent synergistic effect with radiation - PMC [pmc.ncbi.nlm.nih.gov]
- To cite this document: BenchChem. [Application Notes and Protocols for BMS-690154 in Xenograft Models]. BenchChem, [2025]. [Online PDF]. Available at: [https://www.benchchem.com/product/b1149919#how-to-use-bms-690154-in-xenograft-models]

---

**Disclaimer & Data Validity:**

The information provided in this document is for Research Use Only (RUO) and is strictly not intended for diagnostic or therapeutic procedures. While BenchChem strives to provide accurate protocols, we make no warranties, express or implied, regarding the fitness of this product for every specific experimental setup.

**Technical Support:** The protocols provided are for reference purposes. Unsure if this reagent suits your experiment? [[Contact our Ph.D. Support Team for a compatibility check](#)]

**Need Industrial/Bulk Grade?** [Request Custom Synthesis Quote](#)

# BenchChem

Our mission is to be the trusted global source of essential and advanced chemicals, empowering scientists and researchers to drive progress in science and industry.

## Contact

Address: 3281 E Guasti Rd

Ontario, CA 91761, United States

Phone: (601) 213-4426

Email: [info@benchchem.com](mailto:info@benchchem.com)