

Application Notes and Protocols for Azido-PEG1-CH₂CO₂H in Diagnostic Probe Development

Author: BenchChem Technical Support Team. **Date:** December 2025

Compound of Interest

Compound Name: Azido-PEG1-CH₂CO₂H

Cat. No.: B1666422

[Get Quote](#)

For Researchers, Scientists, and Drug Development Professionals

Introduction

Azido-PEG1-CH₂CO₂H is a heterobifunctional linker that has emerged as a valuable tool in the development of sophisticated diagnostic probes. Its architecture, featuring a short polyethylene glycol (PEG) spacer flanked by an azide group and a carboxylic acid, offers a versatile platform for the modular construction of probes for various imaging and diagnostic applications. The PEG linker enhances the solubility and pharmacokinetic properties of the resulting conjugate, while the terminal reactive groups allow for sequential and specific bioconjugation reactions.^{[1][2][3][4]}

The carboxylic acid moiety can be readily activated, typically via EDC/NHS chemistry, to form a stable amide bond with primary amines present on biomolecules such as antibodies, peptides, or amine-functionalized nanoparticles.^[5] The azide group serves as a handle for "click chemistry," enabling highly efficient and bioorthogonal ligation with alkyne-modified reporter molecules, such as fluorescent dyes or chelating agents for radiolabeling, through Copper(I)-Catalyzed Azide-Alkyne Cycloaddition (CuAAC) or Strain-Promoted Azide-Alkyne Cycloaddition (SPAAC). This dual reactivity allows for a flexible and controlled approach to the synthesis of targeted diagnostic probes.

Key Applications in Diagnostic Probe Development

The unique properties of **Azido-PEG1-CH₂CO₂H** make it suitable for a range of applications in diagnostics:

- **Targeted Fluorescent Imaging Probes:** By conjugating a targeting ligand (e.g., an antibody or peptide) to the carboxylic acid end and a fluorescent dye to the azide end, highly specific probes for cellular and in vivo imaging can be constructed. The PEG linker can help to reduce non-specific binding of the probe, thereby improving the signal-to-noise ratio.
- **PET and SPECT Imaging Agents:** The azide group provides a convenient site for the attachment of radiolabeled prosthetic groups. For example, an alkyne-containing chelator can be "clicked" onto the linker, which can then be used to chelate a radionuclide for PET or SPECT imaging. This approach is valuable in the development of targeted radiopharmaceuticals for cancer diagnosis and staging.
- **Functionalized Nanoparticles for Diagnostics:** Nanoparticles, such as gold nanoparticles or quantum dots, can be functionalized with **Azido-PEG1-CH₂CO₂H**. The carboxylic acid can attach to the nanoparticle surface (often amine-functionalized), presenting the azide group for subsequent conjugation of targeting moieties or reporter molecules. This strategy is employed to create multifunctional diagnostic platforms.
- **Immunoassays and Biosensors:** The ability to link biomolecules to surfaces or reporter molecules with high specificity makes this linker suitable for the development of sensitive immunoassays and biosensors.

Quantitative Data Summary

While comprehensive quantitative data for **Azido-PEG1-CH₂CO₂H** in diagnostic probes is not extensively compiled in the literature, the following table summarizes key performance characteristics based on available information for similar PEGylated probes and relevant conjugation chemistries.

Parameter	Observation	Significance in Diagnostic Probe Development	Citations
Conjugation Yield (CuAAC)	Often reported as quantitative or near-quantitative (>95%).	Ensures efficient and reliable synthesis of the final probe, maximizing the use of valuable reagents.	
Binding Affinity (Kd)	PEGylation can sometimes lead to a slight to moderate reduction in the binding affinity of the targeting ligand to its target. This effect is dependent on the PEG chain length and the specific ligand-target interaction. For example, a 13-fold decrease in affinity was observed for a PEGylated Fab fragment.	A critical parameter to consider during probe design. While some affinity may be lost, the benefits of improved pharmacokinetics and reduced non-specific binding can outweigh this. Optimization of the linker length may be necessary.	
Signal-to-Noise Ratio (SNR)	The inclusion of a PEG linker generally improves the SNR in imaging applications by reducing non-specific binding of the probe to non-target tissues and surfaces.	Higher SNR leads to clearer images and more sensitive detection of the target, which is crucial for accurate diagnosis.	
In Vivo Half-life	PEGylation is a well-established method to increase the in vivo	A longer half-life can allow for better tumor accumulation and	

circulation time of
biomolecules.

improved target-to-
background ratios in
imaging studies.

Experimental Protocols

Protocol 1: Two-Step Synthesis of a Targeted Fluorescent Probe

This protocol describes the synthesis of a generic targeted fluorescent probe where a targeting peptide (containing a primary amine) is first conjugated to the carboxylic acid of **Azido-PEG1-CH₂CO₂H**, followed by the "clicking" of an alkyne-modified fluorescent dye.

Materials:

- **Azido-PEG1-CH₂CO₂H**
- Targeting peptide with a primary amine (e.g., lysine residue)
- Alkyne-functionalized fluorescent dye
- N-(3-Dimethylaminopropyl)-N'-ethylcarbodiimide hydrochloride (EDC)
- N-hydroxysuccinimide (NHS)
- Anhydrous Dimethylformamide (DMF)
- 0.1 M MES buffer, pH 6.0
- Phosphate-buffered saline (PBS), pH 7.4
- Copper(II) sulfate (CuSO₄)
- Tris(3-hydroxypropyltriazolylmethyl)amine (THPTA)
- Sodium ascorbate
- Size-exclusion chromatography (SEC) column (e.g., Sephadex G-25)

Step 1: Activation of **Azido-PEG1-CH₂CO₂H** and Conjugation to the Targeting Peptide

- Activation of the Carboxylic Acid:
 - Dissolve **Azido-PEG1-CH₂CO₂H** (1.2 equivalents) in anhydrous DMF.
 - Add NHS (1.2 equivalents) and EDC (1.2 equivalents) to the solution.
 - Stir the reaction mixture at room temperature for 1 hour to form the NHS ester.
- Conjugation to the Peptide:
 - Dissolve the targeting peptide (1 equivalent) in 0.1 M MES buffer (pH 6.0).
 - Add the activated **Azido-PEG1-CH₂CO₂H-NHS** ester solution dropwise to the peptide solution.
 - Adjust the pH of the reaction mixture to 7.2-7.5 with PBS.
 - Allow the reaction to proceed for 2 hours at room temperature with gentle stirring.
- Purification:
 - Purify the azido-functionalized peptide by size-exclusion chromatography using a Sephadex G-25 column equilibrated with PBS (pH 7.4).
 - Collect fractions and confirm the presence of the product using an appropriate method (e.g., LC-MS).

Step 2: Click Chemistry Conjugation of the Fluorescent Dye

- Prepare Click Chemistry Reagents:
 - Prepare a 10 mM stock solution of the alkyne-functionalized fluorescent dye in DMSO.
 - Prepare a 20 mM stock solution of CuSO₄ in water.
 - Prepare a 100 mM stock solution of THPTA in water.

- Prepare a fresh 300 mM stock solution of sodium ascorbate in water.
- Click Reaction:
 - In a microfuge tube, combine the purified azido-peptide (1 equivalent) with the alkyne-dye (1.5 equivalents).
 - Add PBS to bring the reaction to the desired concentration.
 - Add the THPTA solution (5 equivalents relative to CuSO_4).
 - Add the CuSO_4 solution (final concentration of approximately 500 μM).
 - Initiate the reaction by adding the sodium ascorbate solution.
 - Vortex briefly and incubate at room temperature for 30-60 minutes, protected from light.
- Final Purification:
 - Purify the final targeted fluorescent probe using size-exclusion chromatography to remove excess dye and catalyst components.
 - Characterize the final product by UV-Vis spectroscopy to determine the degree of labeling and confirm the presence of both the peptide and the dye.

Visualizations

Signaling Pathways

Diagnostic probes developed using **Azido-PEG1-CH₂CO₂H** often target key signaling pathways implicated in diseases such as cancer. Below are representations of such pathways.

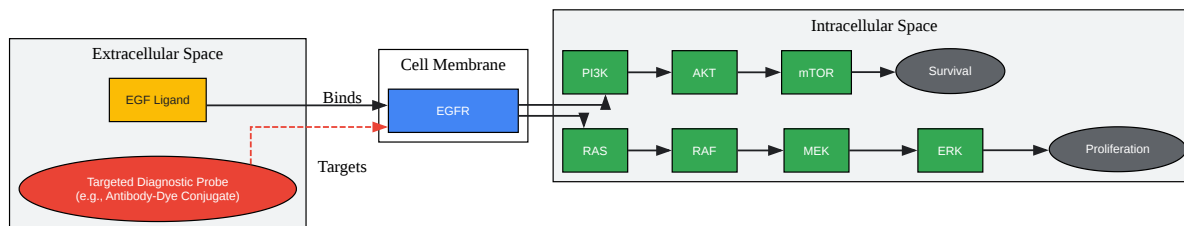

[Click to download full resolution via product page](#)

Caption: EGFR signaling pathway targeted by a diagnostic probe.

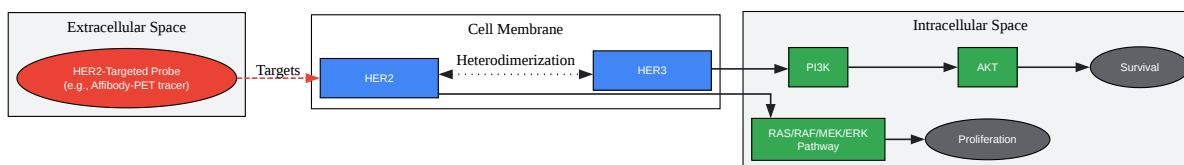

[Click to download full resolution via product page](#)

Caption: HER2 signaling pathway and interaction with a targeted probe.

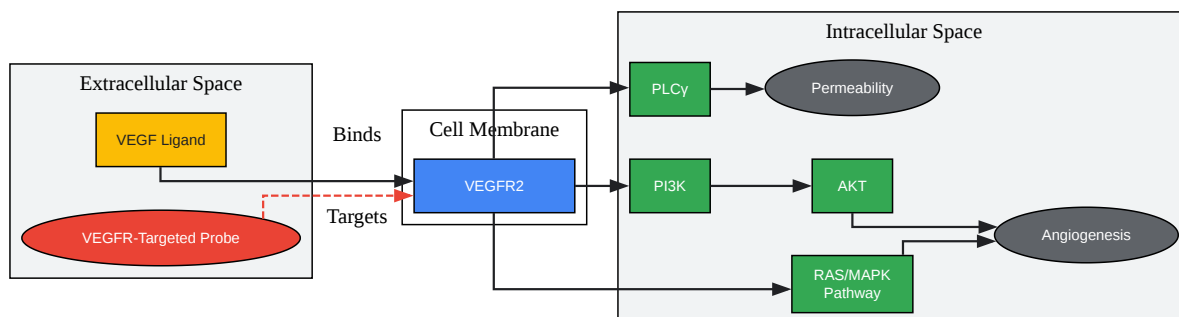

[Click to download full resolution via product page](#)

Caption: VEGFR signaling pathway relevant to anti-angiogenic probes.

Experimental Workflows

The following diagrams illustrate the logical flow of experiments in the development of diagnostic probes using **Azido-PEG1-CH₂CO₂H**.

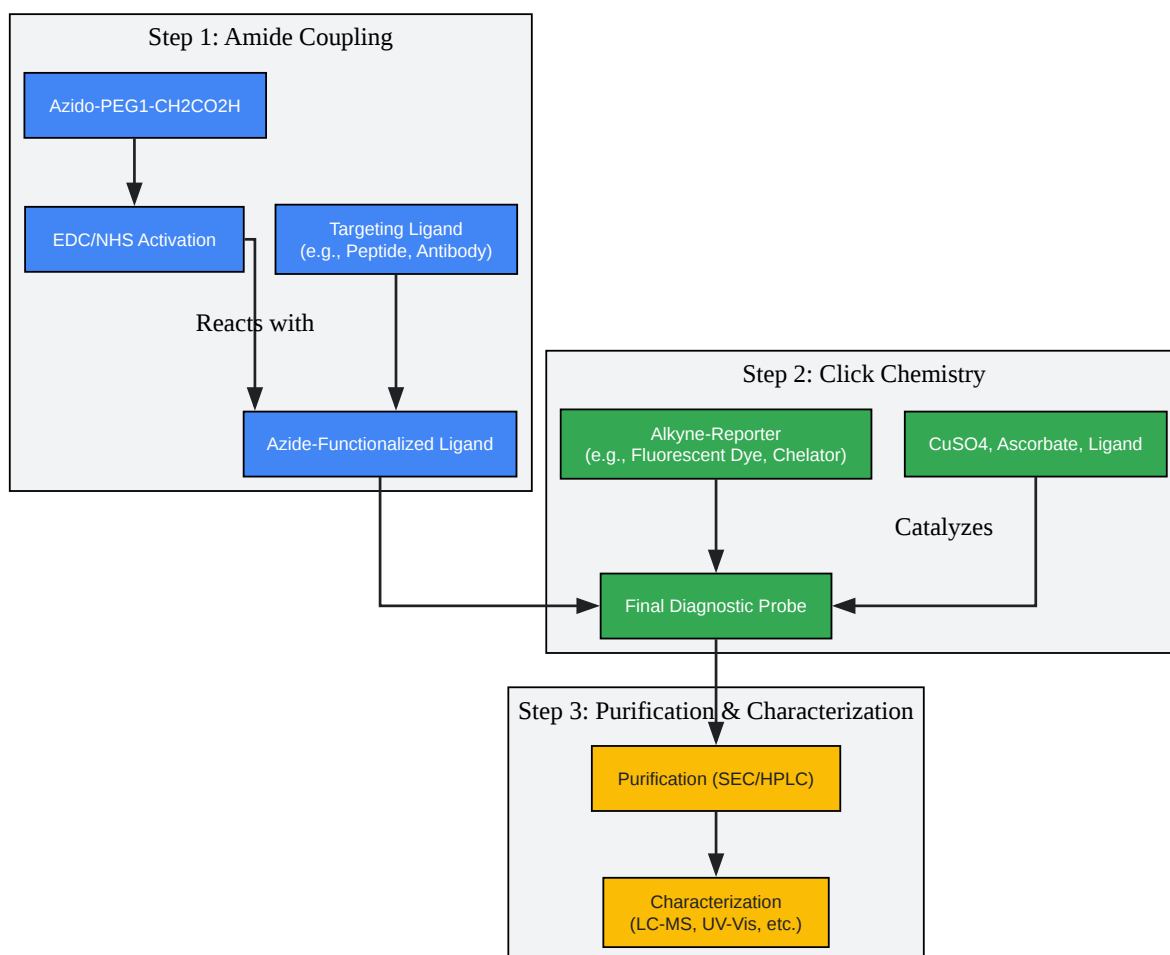

[Click to download full resolution via product page](#)

Caption: Experimental workflow for diagnostic probe synthesis.

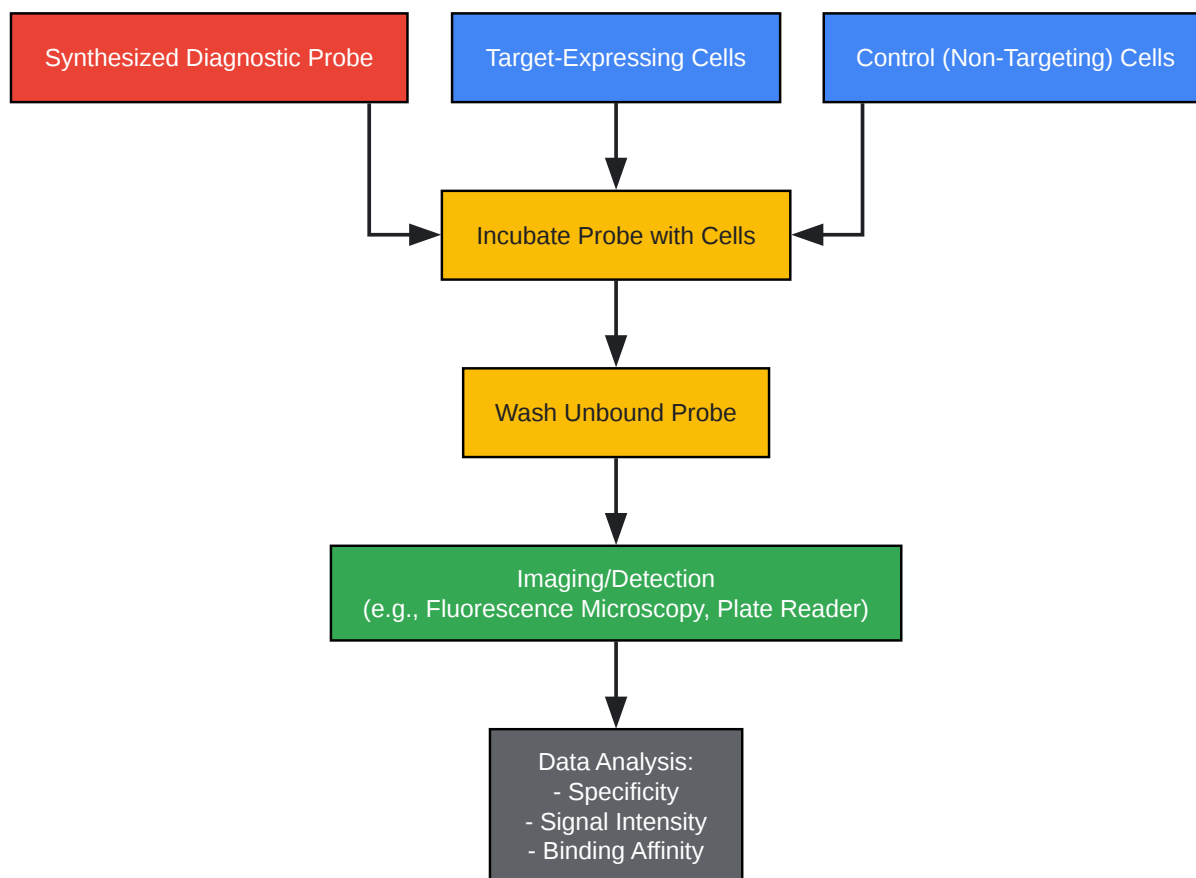

[Click to download full resolution via product page](#)

Need Custom Synthesis?

BenchChem offers custom synthesis for rare earth carbides and specific isotopic labeling.

Email: info@benchchem.com or [Request Quote Online](#).

References

- 1. benchchem.com [benchchem.com]
- 2. "Strategies for HER2 Targeted PET Imaging" by Maxwell Adams Ducharme [digitalcommons.library.uab.edu]
- 3. Azide PEG, Azide linker for Click Chemistry Reactions | AxisPharm [axispharm.com]
- 4. PEG Azide, Azide linker, Click Chemistry tools | BroadPharm [broadpharm.com]

- 5. [broadpharm.com](https://www.broadpharm.com) [[broadpharm.com](https://www.broadpharm.com)]
- To cite this document: BenchChem. [Application Notes and Protocols for Azido-PEG1-CH₂CO₂H in Diagnostic Probe Development]. BenchChem, [2025]. [Online PDF]. Available at: [<https://www.benchchem.com/product/b1666422#azido-peg1-ch2co2h-in-diagnostic-probe-development>]

Disclaimer & Data Validity:

The information provided in this document is for Research Use Only (RUO) and is strictly not intended for diagnostic or therapeutic procedures. While BenchChem strives to provide accurate protocols, we make no warranties, express or implied, regarding the fitness of this product for every specific experimental setup.

Technical Support: The protocols provided are for reference purposes. Unsure if this reagent suits your experiment? [[Contact our Ph.D. Support Team for a compatibility check](#)]

Need Industrial/Bulk Grade? [Request Custom Synthesis Quote](#)

BenchChem

Our mission is to be the trusted global source of essential and advanced chemicals, empowering scientists and researchers to drive progress in science and industry.

Contact

Address: 3281 E Guasti Rd

Ontario, CA 91761, United States

Phone: (601) 213-4426

Email: info@benchchem.com