

Application Notes and Protocols for Aloeresin J in Drug Development

Author: BenchChem Technical Support Team. **Date:** December 2025

Compound of Interest

Compound Name: Aloeresin J

Cat. No.: B12378171

[Get Quote](#)

For Researchers, Scientists, and Drug Development Professionals

These application notes provide a comprehensive overview of **Aloeresin J**, a bioactive compound with significant potential for drug development. This document summarizes its biochemical properties, therapeutic effects, and key signaling pathways, and provides detailed protocols for relevant in vitro and in vivo experiments.

Introduction to Aloeresin J

Aloeresin J, also known as Aloesin or Aloeresin B, is a C-glycosylated chromone predominantly found in the exudates of Aloe vera plants.[1][2] It has garnered considerable interest in the pharmaceutical and cosmetic industries due to its diverse biological activities, including anti-inflammatory, antioxidant, anti-cancer, and wound healing properties.[3][4][5][6] Its therapeutic potential is attributed to its ability to modulate key cellular signaling pathways.[3][4]

Physicochemical Properties

Aloeresin J is a white, crystalline solid soluble in organic solvents such as methanol, ethanol, and DMSO.[7] Its molecular formula is C₁₉H₂₂O₉ with a molar mass of 394.37 g/mol.[7]

Table 1: Physicochemical Properties of **Aloeresin J**

Property	Value	Reference
Molecular Formula	C19H22O9	[7]
Molar Mass	394.37 g/mol	[7]
Appearance	White needle crystal	[7]
Solubility	Soluble in methanol, ethanol, DMSO	[7]
Storage	2-8°C under inert gas	[7]

Potential Therapeutic Applications and Mechanism of Action

Aloeresin J has demonstrated efficacy in several therapeutic areas, primarily through the modulation of key signaling pathways.

3.1. Wound Healing

Aloeresin J accelerates cutaneous wound healing by promoting cell migration, angiogenesis, and collagen deposition.[3] These effects are mediated through the activation of the MAPK/Rho and Smad signaling pathways.[3]

3.2. Anti-Inflammatory Effects

The anti-inflammatory properties of **Aloeresin J** are attributed to its ability to inhibit the production of pro-inflammatory cytokines such as TNF- α , IL-1 β , and IL-6.[1] This is achieved by inhibiting the activation of the NF- κ B signaling pathway.[1]

3.3. Anti-Cancer Activity

In ovarian cancer cells, **Aloeresin J** has been shown to suppress cell growth and metastasis by inhibiting the phosphorylation of the MAPK signaling pathway.[4][8] It can induce apoptosis and arrest the cell cycle at the S-phase in a dose-dependent manner.[5][8]

3.4. Other Applications

Aloeresin J also exhibits tyrosinase inhibitory activity, making it a potential agent for treating hyperpigmentation and for use in cosmetic applications.[2] It also shows antioxidant and antibacterial effects.[1]

Table 2: Summary of Quantitative Data for **Aloeresin J**

Parameter	Value	Cell/Model System	Application	Reference
IC50 (Tyrosinase inhibition)	0.9 mM	Skin depigmentation	[9]	
In vitro cell migration	1, 5, 10 μ M	Skin cell lines	Wound healing	[3]
In vivo wound healing	0.1%, 0.5%	Hairless mice	Wound healing	[3]
Anti-cancer (cell growth inhibition)	0-40 μ M	SKOV3 ovarian cancer cells	Ovarian cancer	[8]
Anti-cancer (cell cycle arrest)	0-10 μ M	SKOV3 ovarian cancer cells	Ovarian cancer	[8]
In vivo tumor growth inhibition	20, 40 mg/kg	Xenograft model of ovarian cancer	Ovarian cancer	[8]

Signaling Pathways Modulated by Aloeresin J

4.1. MAPK/Rho and Smad Signaling in Wound Healing

Aloeresin J promotes wound healing by activating key proteins in the MAPK/Rho and Smad signaling cascades, which are crucial for cell migration, angiogenesis, and tissue remodeling. [3]

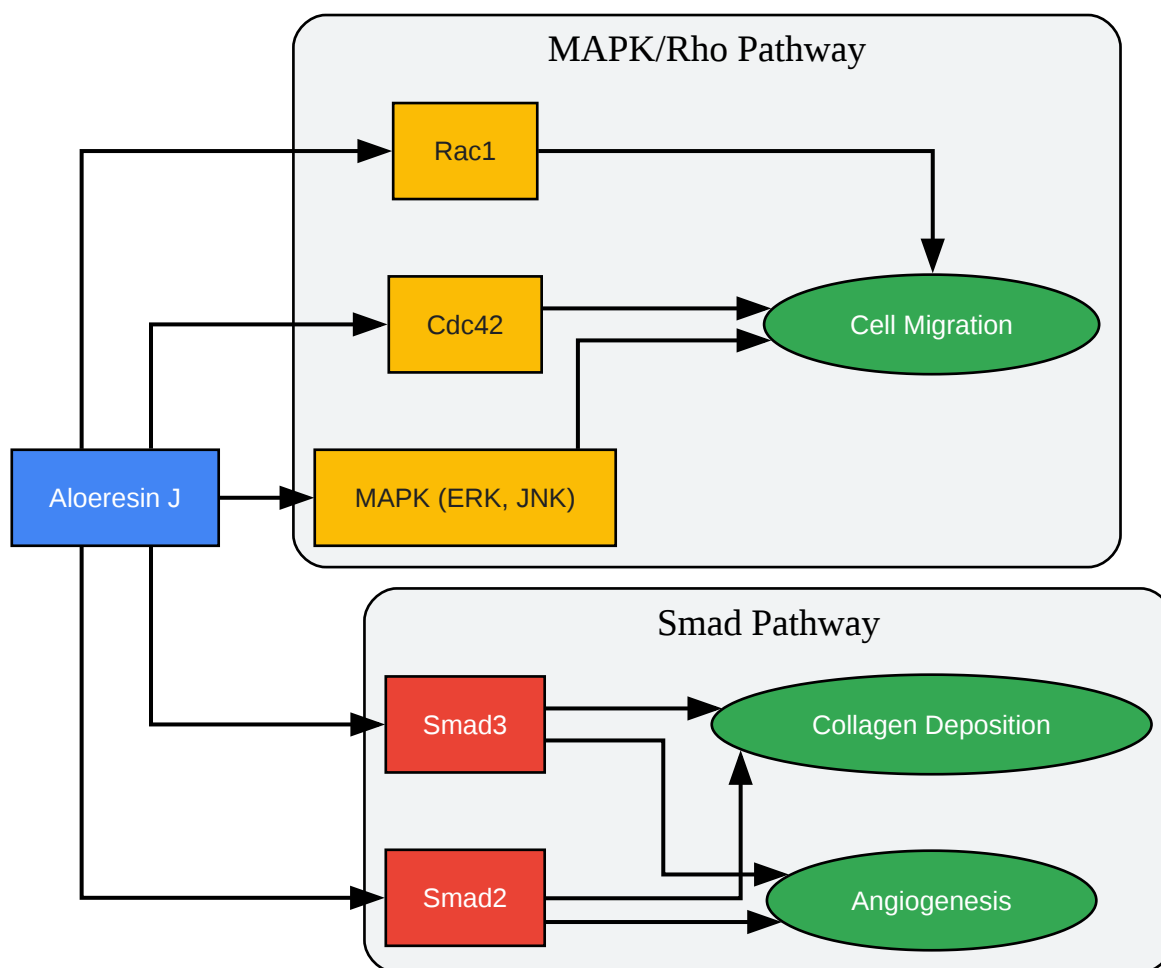

[Click to download full resolution via product page](#)

Aloeresin J in Wound Healing Pathways

4.2. NF- κ B Signaling in Inflammation

Aloeresin J exerts its anti-inflammatory effects by inhibiting the NF- κ B signaling pathway, which prevents the transcription of pro-inflammatory cytokines.[1]

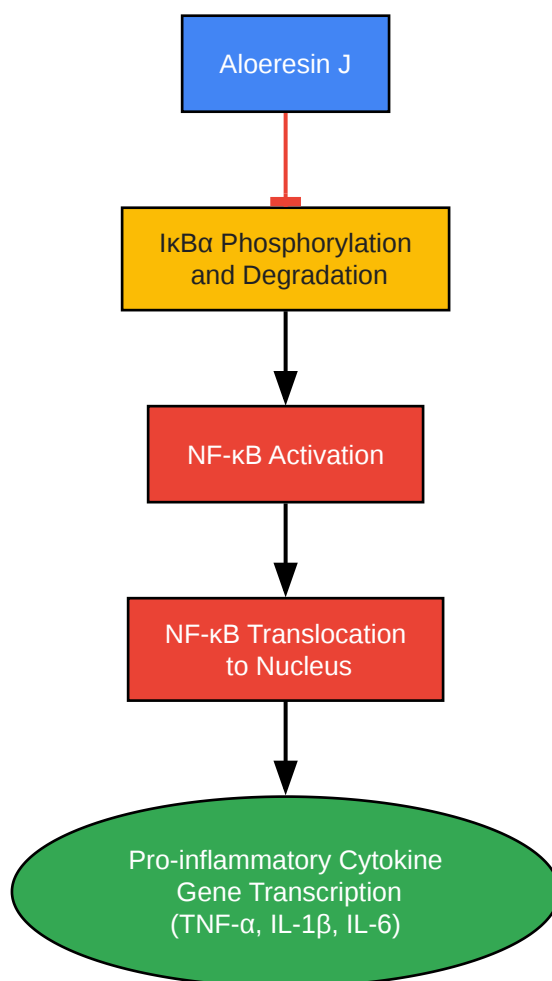

[Click to download full resolution via product page](#)

Aloeresin J in Anti-Inflammatory Pathway

Experimental Protocols

5.1. In Vitro Wound Healing (Scratch) Assay

This protocol is designed to assess the effect of **Aloeresin J** on cell migration in vitro.

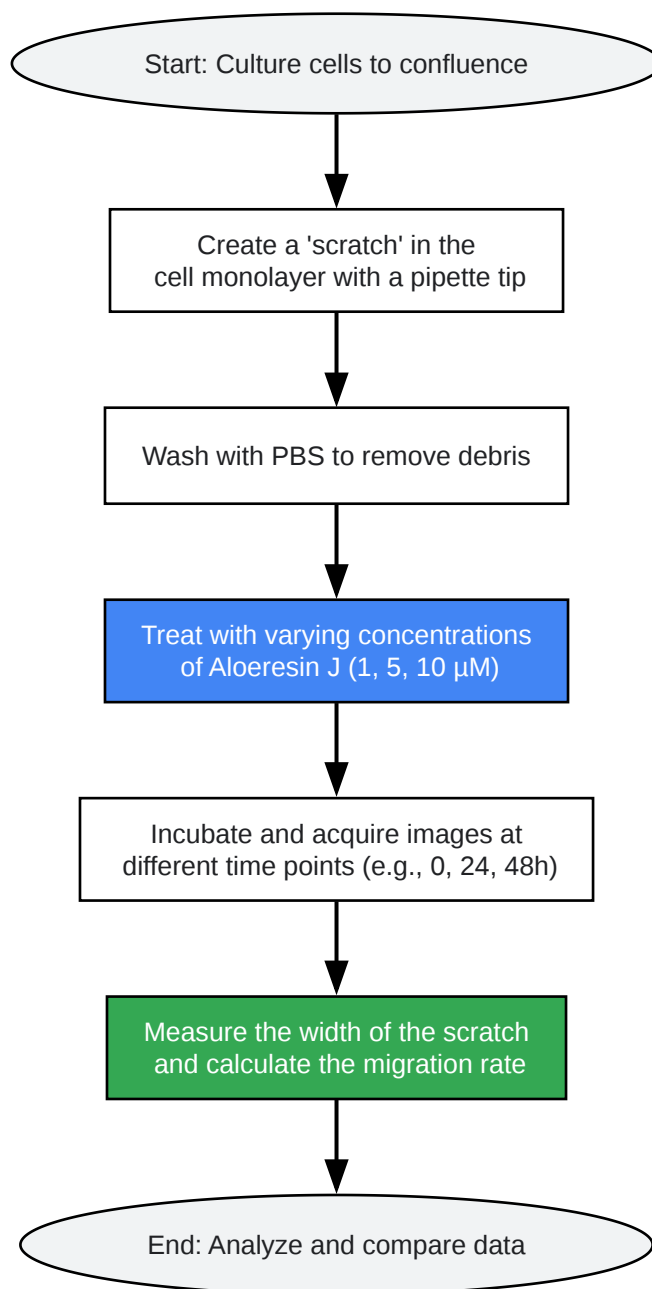

[Click to download full resolution via product page](#)

In Vitro Wound Healing Assay Workflow

Methodology:

- Cell Culture: Plate skin cell lines (e.g., HaCaT keratinocytes or NIH3T3 fibroblasts) in 6-well plates and culture until a confluent monolayer is formed.

- **Scratch Creation:** Create a linear scratch in the cell monolayer using a sterile 200 μ L pipette tip.
- **Washing:** Gently wash the wells with phosphate-buffered saline (PBS) to remove detached cells and debris.
- **Treatment:** Replace the medium with fresh culture medium containing various concentrations of **Aloeresin J** (e.g., 1, 5, and 10 μ M) and a vehicle control (e.g., DMSO).
- **Image Acquisition:** Capture images of the scratch at the beginning of the experiment (0 hours) and at subsequent time points (e.g., 24 and 48 hours) using a microscope with a camera.
- **Data Analysis:** Measure the width of the scratch at multiple points for each image. Calculate the percentage of wound closure or cell migration rate for each treatment group compared to the control.

5.2. In Vivo Cutaneous Wound Healing Model

This protocol outlines the assessment of **Aloeresin J**'s wound healing properties in a mouse model.

Methodology:

- **Animal Model:** Use hairless mice (e.g., BALB/c nude mice).
- **Wound Creation:** Anesthetize the mice and create a full-thickness excisional wound on the dorsal skin using a sterile biopsy punch (e.g., 4 mm diameter).
- **Topical Treatment:** Apply a topical formulation of **Aloeresin J** (e.g., 0.1% and 0.5% in a suitable vehicle) to the wound site daily. A control group should receive the vehicle only.
- **Wound Closure Measurement:** Photograph the wounds daily and measure the wound area using image analysis software. Calculate the percentage of wound closure over time.
- **Histological Analysis:** On selected days post-wounding, euthanize a subset of mice and excise the wound tissue. Process the tissue for histological staining (e.g., H&E for overall

morphology, Masson's trichrome for collagen deposition) and immunohistochemistry for markers of angiogenesis (e.g., CD31) and cell proliferation (e.g., Ki-67).

- Biochemical Analysis: Homogenize a portion of the wound tissue to perform ELISAs for cytokines and growth factors or Western blotting to analyze the phosphorylation status of proteins in the MAPK/Rho and Smad pathways.

5.3. Western Blot Analysis for Protein Phosphorylation

This protocol is for determining the effect of **Aloeresin J** on the phosphorylation of signaling proteins.

Methodology:

- Cell Lysis: Treat cells with **Aloeresin J** for the desired time, then lyse the cells in RIPA buffer containing protease and phosphatase inhibitors.
- Protein Quantification: Determine the protein concentration of the lysates using a BCA or Bradford assay.
- SDS-PAGE and Transfer: Separate equal amounts of protein on an SDS-polyacrylamide gel and transfer the proteins to a PVDF or nitrocellulose membrane.
- Immunoblotting:
 - Block the membrane with 5% non-fat milk or BSA in TBST for 1 hour at room temperature.
 - Incubate the membrane with a primary antibody specific for the phosphorylated form of the protein of interest (e.g., phospho-ERK, phospho-Smad2) overnight at 4°C.
 - Wash the membrane with TBST and incubate with a horseradish peroxidase (HRP)-conjugated secondary antibody for 1 hour at room temperature.
- Detection: Detect the protein bands using an enhanced chemiluminescence (ECL) substrate and an imaging system.
- Stripping and Re-probing: Strip the membrane and re-probe with an antibody for the total form of the protein to normalize for loading differences.

- Densitometry: Quantify the band intensities using image analysis software.

Conclusion

Aloeresin J presents a promising scaffold for the development of novel therapeutics for a range of conditions, including chronic wounds, inflammatory disorders, and cancer. The provided protocols offer a starting point for researchers to investigate its mechanisms of action and evaluate its efficacy in relevant preclinical models. Further research is warranted to fully elucidate its therapeutic potential and advance it through the drug development pipeline.

Need Custom Synthesis?

BenchChem offers custom synthesis for rare earth carbides and specific isotopic labeling.

Email: info@benchchem.com or [Request Quote Online](#).

References

- 1. What are the research findings on Aloesin's anti - inflammatory effects? - Blog [timyeehealth.com]
- 2. mdpi.com [mdpi.com]
- 3. Aloesin from Aloe vera accelerates skin wound healing by modulating MAPK/Rho and Smad signaling pathways in vitro and in vivo - PubMed [pubmed.ncbi.nlm.nih.gov]
- 4. researchgate.net [researchgate.net]
- 5. bocsci.com [bocsci.com]
- 6. researchgate.net [researchgate.net]
- 7. chembk.com [chembk.com]
- 8. medchemexpress.com [medchemexpress.com]
- 9. Aloesin | Tyrosinase | TargetMol [targetmol.com]
- To cite this document: BenchChem. [Application Notes and Protocols for Aloeresin J in Drug Development]. BenchChem, [2025]. [Online PDF]. Available at: [https://www.benchchem.com/product/b12378171#aloeresin-j-as-a-potential-candidate-for-drug-development]

Disclaimer & Data Validity:

The information provided in this document is for Research Use Only (RUO) and is strictly not intended for diagnostic or therapeutic procedures. While BenchChem strives to provide accurate protocols, we make no warranties, express or implied, regarding the fitness of this product for every specific experimental setup.

Technical Support: The protocols provided are for reference purposes. Unsure if this reagent suits your experiment? [[Contact our Ph.D. Support Team for a compatibility check](#)]

Need Industrial/Bulk Grade? [Request Custom Synthesis Quote](#)

BenchChem

Our mission is to be the trusted global source of essential and advanced chemicals, empowering scientists and researchers to drive progress in science and industry.

Contact

Address: 3281 E Guasti Rd
Ontario, CA 91761, United States
Phone: (601) 213-4426
Email: info@benchchem.com