

# Application Notes and Protocols for ATP-Red 1 in Fluorescence Microscopy

**Author:** BenchChem Technical Support Team. **Date:** December 2025

## Compound of Interest

Compound Name: ATP-Red 1

Cat. No.: B560525

[Get Quote](#)

For Researchers, Scientists, and Drug Development Professionals

## Introduction

Adenosine triphosphate (ATP) is the primary energy currency of the cell, fueling a vast array of cellular processes.[1] Its intracellular concentration is a key indicator of metabolic activity and overall cell health.[2] **ATP-Red 1** is a highly selective, cell-permeable fluorescent probe designed for the real-time monitoring of intracellular ATP levels, particularly within the mitochondria, in living cells.[3][4] This multisite-binding, switchable probe exhibits a significant increase in fluorescence intensity upon binding to ATP, making it a valuable tool for studying cellular bioenergetics, mitochondrial function, and for screening compounds that modulate cellular metabolism.[5]

## Mechanism of Action

**ATP-Red 1** operates as a "switchable" fluorescent probe. In its unbound state, the molecule exists in a non-fluorescent, closed-ring conformation. Upon encountering the negatively charged phosphate groups of ATP, a multi-site interaction occurs, leading to the opening of the ring structure. This conformational change results in a dramatic increase in the probe's fluorescence emission. This mechanism provides high selectivity for ATP over other nucleotides such as ADP and AMP.

## Data Presentation

## Physicochemical and Spectroscopic Properties of ATP-Red 1

Property	Value	Reference
Molecular Weight	561.48 g/mol	
Excitation Wavelength (max)	510-570 nm	
Emission Wavelength (max)	585-590 nm	
Solvent for Stock Solution	DMSO	
Recommended Stock Concentration	10 mM	

## Fluorescence Intensity and Selectivity of ATP-Red 1

Analyte (Concentration)	Fold Increase in Fluorescence (F/F <sub>0</sub> )	Reference
ATP (5 mM)	5.6	
ADP (5 mM)	Slight increase	
AMP (5 mM)	Slight increase	
Other Biomolecules (Metal ions, carbohydrates, other NTPs/NDPs)	No significant increase	

## Experimental Protocols

### Preparation of ATP-Red 1 Stock Solution

- Before opening, centrifuge the vial of lyophilized **ATP-Red 1** to ensure all the powder is at the bottom.
- Warm the vial to room temperature.
- Add the appropriate volume of high-quality, anhydrous dimethyl sulfoxide (DMSO) to achieve a 10 mM stock solution. For example, for 1 mg of **ATP-Red 1** (MW = 561.48), add 178  $\mu$ L of

DMSO.

- Vortex briefly to dissolve the powder completely.
- Aliquot the stock solution into smaller volumes to avoid repeated freeze-thaw cycles.
- Store the aliquots at -20°C or -80°C, protected from light. The stock solution is stable for at least 6 months at -80°C.

## Staining Protocol for Live-Cell Imaging

- Cell Seeding: Plate cells in a suitable imaging dish or plate (e.g., glass-bottom dishes, 96-well imaging plates) and culture until they reach the desired confluency.
- Preparation of Working Solution: On the day of the experiment, thaw an aliquot of the 10 mM **ATP-Red 1** stock solution. Dilute the stock solution in serum-free medium or a suitable buffer (e.g., PBS) to a final working concentration of 2.5-10 µM. The optimal concentration may vary depending on the cell type and experimental conditions and should be determined empirically.
- Cell Staining: Remove the culture medium from the cells and wash once with warm serum-free medium or buffer. Add the **ATP-Red 1** working solution to the cells.
- Incubation: Incubate the cells at 37°C for 15-30 minutes, protected from light.
- Washing: After incubation, remove the staining solution and wash the cells two to three times with warm serum-free medium or buffer to remove any unbound probe.
- Imaging: Add fresh, warm culture medium or buffer to the cells. Image the cells immediately using a fluorescence microscope equipped with appropriate filters for red fluorescence (e.g., TRITC or Texas Red filter set).

## Experimental Controls

- Positive Control: To confirm that **ATP-Red 1** is responsive to changes in intracellular ATP, cells can be treated with a known modulator of mitochondrial function. For example, treatment with oligomycin, an inhibitor of ATP synthase, is expected to decrease mitochondrial ATP levels and thus reduce **ATP-Red 1** fluorescence.

- Negative Control: Untreated cells stained with **ATP-Red 1** serve as a baseline for normal intracellular ATP levels.
- Autofluorescence Control: An unstained sample of cells should be imaged using the same settings to assess the level of cellular autofluorescence.

## Mandatory Visualizations

### Signaling Pathways and Experimental Workflows

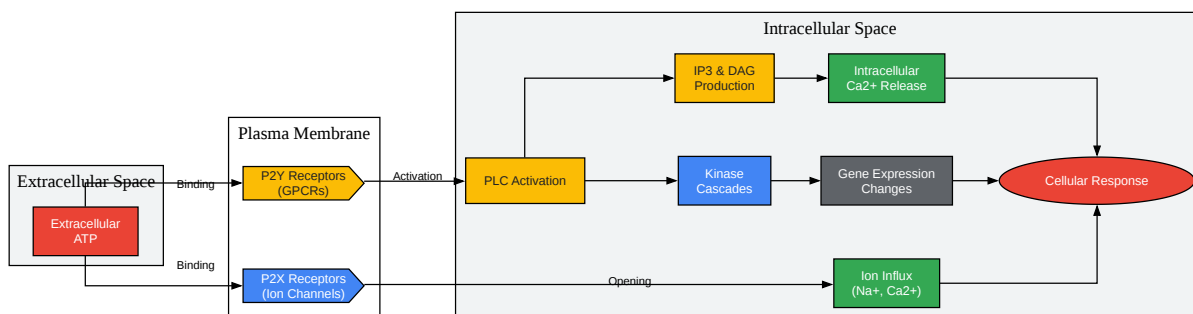

[Click to download full resolution via product page](#)

Caption: Extracellular ATP signaling pathways.

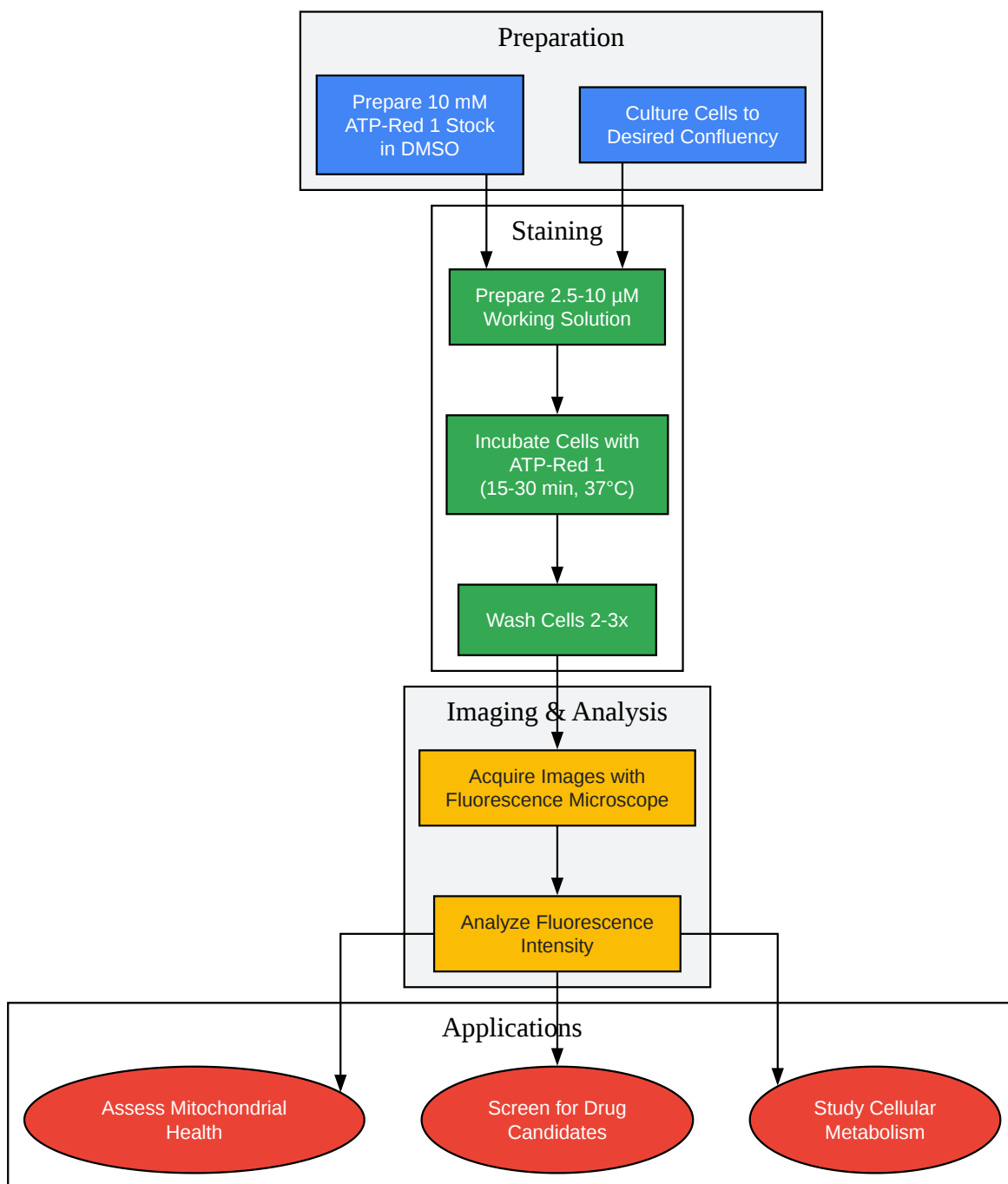

[Click to download full resolution via product page](#)

Caption: Experimental workflow for using **ATP-Red 1**.

## Applications in Research and Drug Development

### Assessing Mitochondrial Function and Cellular Metabolism

**ATP-Red 1** is an excellent tool for investigating mitochondrial health and dysfunction. A decrease in **ATP-Red 1** fluorescence can indicate impaired mitochondrial respiration or uncoupling of oxidative phosphorylation. This makes it useful for studying metabolic disorders, neurodegenerative diseases, and the effects of toxins on cellular energy production. For instance, a reduction in fluorescence was observed in OSCC cells after treatment with KCN, an inhibitor of oxidative phosphorylation, demonstrating the probe's ability to detect decreased mitochondrial ATP levels.

### Drug Discovery and Development

In the context of drug development, **ATP-Red 1** can be employed in high-throughput screening assays to identify compounds that modulate mitochondrial function. This is particularly relevant for cancer research, where altered cellular metabolism is a hallmark of cancer cells.

Compounds that selectively target the energy metabolism of cancer cells can be identified by their effect on **ATP-Red 1** fluorescence. For example, **ATP-Red 1** has been used to demonstrate that certain drugs can induce an increase in intracellular ATP levels in Jurkat cells. Furthermore, it has been instrumental in showing that cancer cells with high ATP levels exhibit increased drug resistance.

### Studying ATP Signaling

ATP plays a crucial role as a signaling molecule in both intracellular and extracellular environments. Extracellular ATP can act as a neurotransmitter and a signaling molecule in the immune system through its interaction with purinergic receptors (P2X and P2Y). While **ATP-Red 1** primarily measures intracellular ATP, it can be used in conjunction with other tools to dissect the downstream consequences of purinergic signaling on cellular energy status. Intracellularly, ATP is a key substrate for kinases and adenylyl cyclase, initiating signaling cascades that regulate a multitude of cellular processes. Changes in ATP levels, as detected by **ATP-Red 1**, can therefore reflect alterations in these fundamental signaling pathways.

### Troubleshooting

Problem	Possible Cause	Suggested Solution
No or weak fluorescence signal	- Cell death- Incorrect filter set- Low probe concentration- Impaired mitochondrial function	- Check cell viability with a live/dead stain.- Ensure the use of a TRITC or Texas Red filter set.- Optimize the ATP-Red 1 working concentration.- Use a positive control (e.g., healthy, actively respiring cells) to confirm probe functionality.
High background fluorescence	- Incomplete washing- Autofluorescence	- Increase the number and duration of washing steps.- Image an unstained control to determine the level of autofluorescence and adjust imaging settings accordingly.
Phototoxicity or photobleaching	- Excessive light exposure	- Reduce the excitation light intensity and/or exposure time.- Use an anti-fade mounting medium for fixed-cell imaging.

## Conclusion

**ATP-Red 1** is a powerful and versatile fluorescent probe for the quantitative and real-time analysis of intracellular ATP levels in living cells. Its high selectivity and sensitivity make it an invaluable tool for researchers and drug development professionals in a wide range of fields, from basic cell biology and metabolism to cancer research and neurobiology. The detailed protocols and application notes provided here serve as a comprehensive guide for the successful implementation of **ATP-Red 1** in fluorescence microscopy studies.

### Need Custom Synthesis?

BenchChem offers custom synthesis for rare earth carbides and specific isotopic labeling.

Email: [info@benchchem.com](mailto:info@benchchem.com) or [Request Quote Online](#).

## References

- 1. ATP-Red 1 | Fluorescent probe | TargetMol [[targetmol.com](#)]
- 2. A Multisite-Binding Switchable Fluorescent Probe for Monitoring Mitochondrial ATP Level Fluctuation in Live Cells - PubMed [[pubmed.ncbi.nlm.nih.gov](#)]
- 3. [researchgate.net](#) [[researchgate.net](#)]
- 4. [medchemexpress.com](#) [[medchemexpress.com](#)]
- 5. [news-medical.net](#) [[news-medical.net](#)]
- To cite this document: BenchChem. [Application Notes and Protocols for ATP-Red 1 in Fluorescence Microscopy]. BenchChem, [2025]. [Online PDF]. Available at: [<https://www.benchchem.com/product/b560525#using-atp-red-1-in-fluorescence-microscopy>]

---

### Disclaimer & Data Validity:

The information provided in this document is for Research Use Only (RUO) and is strictly not intended for diagnostic or therapeutic procedures. While BenchChem strives to provide accurate protocols, we make no warranties, express or implied, regarding the fitness of this product for every specific experimental setup.

**Technical Support:** The protocols provided are for reference purposes. Unsure if this reagent suits your experiment? [[Contact our Ph.D. Support Team for a compatibility check](#)]

**Need Industrial/Bulk Grade?** [Request Custom Synthesis Quote](#)

## BenchChem

Our mission is to be the trusted global source of essential and advanced chemicals, empowering scientists and researchers to drive progress in science and industry.

### Contact

Address: 3281 E Guasti Rd  
Ontario, CA 91761, United States  
Phone: (601) 213-4426  
Email: [info@benchchem.com](mailto:info@benchchem.com)