

Application Notes and Protocols: WAY-262611 and CRISPR/Cas9 DKK1 Knockout Studies

Author: BenchChem Technical Support Team. **Date:** December 2025

Compound of Interest

Compound Name: WAY-262611

Cat. No.: B611799

[Get Quote](#)

For Researchers, Scientists, and Drug Development Professionals

These application notes provide a detailed overview and experimental protocols for studying the effects of the small molecule DKK1 inhibitor, **WAY-262611**, and for generating DKK1 knockout cell lines using the CRISPR/Cas9 system. This document is intended to guide researchers in comparing pharmacological inhibition versus genetic knockout of DKK1, a key negative regulator of the Wnt/ β -catenin signaling pathway.

Introduction

Dickkopf-1 (DKK1) is a secreted protein that antagonizes the Wnt/ β -catenin signaling pathway by binding to the LRP5/6 co-receptor, thereby preventing the formation of the Wnt-Frizzled-LRP5/6 receptor complex. Dysregulation of DKK1 has been implicated in various diseases, including cancer and bone disorders. Understanding the precise role of DKK1 is crucial for the development of novel therapeutics. Two primary methods for interrogating DKK1 function are through pharmacological inhibition using small molecules like **WAY-262611**, and genetic ablation using tools such as CRISPR/Cas9.

WAY-262611 is a potent and specific small molecule inhibitor of DKK1 that has been shown to activate Wnt/ β -catenin signaling.[1] In contrast, CRISPR/Cas9-mediated gene knockout offers a method for the complete and permanent removal of DKK1 function. This document provides a comparative framework and detailed protocols for both approaches.

Data Presentation

The following tables summarize quantitative data from studies utilizing **WAY-262611** and DKK1 knockout.

Table 1: In Vitro Efficacy of **WAY-262611**

Cell Line	Assay	Endpoint	Value	Citation
TCF-Luciferase Reporter	Wnt/ β -catenin signaling activation	EC50	0.63 μ M	[1]
U2OS (Osteosarcoma)	Cell Viability (CCK8)	IC50	3 μ M	[2]
HOS (Osteosarcoma)	Cell Viability (CCK8)	IC50	8 μ M	[2]
SaOS2 (Osteosarcoma)	Cell Viability (CCK8)	IC50	8 μ mol/L	[2]
RD (Rhabdomyosarcoma)	Cell Proliferation	IC50	\sim 0.2 μ M	
CW9019 (Rhabdomyosarcoma)	Cell Proliferation	IC50	\sim 0.2 μ M	

Table 2: Effects of DKK1 Knockout on Bone Phenotype in Mice

Parameter	Genotype	Fold Change vs. Wild Type	Citation
Trabecular Bone Volume (Distal Femur)	Dkk1 KO	Up to 3-fold increase	
Trabecular Bone Volume (Vertebrae)	Dkk1 KO	Up to 2-fold increase	
Whole Body Bone Density	Dkk1 KO	Increased	

Table 3: Comparison of **WAY-262611** and DKK1 Knockout on β -catenin Nuclear Localization in SaOS2 Osteosarcoma Cells

Condition	Treatment	Outcome	Citation
Scramble Control (SC) Cells	Vehicle	Baseline nuclear β -catenin	
Scramble Control (SC) Cells	WAY-262611 (6 μ M)	Increased nuclear localization of β -catenin	
DKK1 Knockout (KO) Cells	Vehicle	Baseline nuclear β -catenin	
DKK1 Knockout (KO) Cells	WAY-262611 (6 μ M)	No increase in nuclear localization of β -catenin	

Experimental Protocols

Protocol 1: In Vitro Treatment of Cancer Cells with **WAY-262611**

This protocol describes the general procedure for treating adherent cancer cell lines with **WAY-262611** to assess its effects on cell viability, proliferation, and signaling pathways.

Materials:

- **WAY-262611** (dissolved in DMSO to create a stock solution, e.g., 10 mM)
- Adherent cancer cell line of interest (e.g., SaOS2, U2OS, HOS)
- Complete cell culture medium (e.g., DMEM or McCoy's 5A with 10% FBS)
- Phosphate-buffered saline (PBS)
- Trypsin-EDTA
- 96-well and 6-well tissue culture plates
- Cell viability reagent (e.g., CCK8, MTT)
- Reagents for downstream analysis (e.g., lysis buffer for Western blot, fixation and permeabilization buffers for immunofluorescence)

Procedure:

- Cell Seeding:
 - For viability assays, seed cells in a 96-well plate at a density of 5,000-10,000 cells per well.
 - For protein or RNA analysis, seed cells in a 6-well plate at a density that will result in 70-80% confluency at the time of harvest.
 - Allow cells to adhere overnight in a humidified incubator at 37°C and 5% CO₂.
- **WAY-262611** Treatment:
 - Prepare serial dilutions of **WAY-262611** in complete culture medium from the stock solution. A typical concentration range for IC₅₀ determination is 0.1 to 10 μM.
 - Include a vehicle control (DMSO) at the same final concentration as the highest concentration of **WAY-262611** used.

- Remove the old medium from the cells and replace it with the medium containing the desired concentrations of **WAY-262611** or vehicle.
- Incubation:
 - Incubate the cells for the desired period (e.g., 24, 48, or 72 hours for viability assays; shorter times may be used for signaling pathway analysis).
- Downstream Analysis:
 - Cell Viability Assay (e.g., CCK8): Add the reagent to each well according to the manufacturer's instructions and measure the absorbance at the appropriate wavelength.
 - Western Blot Analysis: Wash cells with ice-cold PBS, lyse the cells, and collect the protein lysates. Determine protein concentration and proceed with SDS-PAGE and immunoblotting for proteins of interest (e.g., DKK1, β -catenin, downstream targets).
 - Immunofluorescence for β -catenin Localization: Grow cells on coverslips. After treatment, fix, permeabilize, and stain with a primary antibody against β -catenin and a fluorescently labeled secondary antibody. Counterstain nuclei with DAPI or Hoechst. Analyze by fluorescence microscopy.

Protocol 2: CRISPR/Cas9-Mediated Knockout of DKK1 in a Cancer Cell Line

This protocol provides a general workflow for generating a DKK1 knockout cell line using the CRISPR/Cas9 system.

Materials:

- Cancer cell line of interest (e.g., SaOS2)
- CRISPR/Cas9 plasmid expressing Cas9 and a guide RNA (gRNA) targeting DKK1 (e.g., pX458 which also expresses GFP for selection).
- Scrambled gRNA control plasmid.
- Lipofectamine-based transfection reagent or electroporation system.

- Complete cell culture medium.
- Puromycin or other selection antibiotic (if the plasmid contains a resistance gene).
- 96-well plates for single-cell cloning.
- Reagents for genomic DNA extraction, PCR, and Sanger sequencing.
- Reagents for Western blot or ELISA to validate DKK1 protein knockout.

Procedure:

- gRNA Design and Plasmid Construction:
 - Design gRNAs targeting an early exon of the DKK1 gene using online tools (e.g., CHOPCHOP). Select gRNAs with high predicted on-target efficiency and low off-target scores.
 - Synthesize and clone the gRNA sequences into a suitable Cas9 expression vector according to the manufacturer's protocol.
- Transfection:
 - Transfect the DKK1-targeting CRISPR/Cas9 plasmid and the scrambled control plasmid into the target cells using a suitable method (e.g., lipid-based transfection or electroporation). Optimize transfection efficiency for the specific cell line.
- Selection and Single-Cell Cloning:
 - For plasmids with a fluorescent marker (e.g., GFP): 48 hours post-transfection, use fluorescence-activated cell sorting (FACS) to isolate single GFP-positive cells into individual wells of a 96-well plate.
 - For plasmids with an antibiotic resistance gene: 48 hours post-transfection, begin selection with the appropriate antibiotic (e.g., puromycin). Once non-transfected cells are eliminated, perform limiting dilution to seed single cells into 96-well plates.
 - Allow single cells to grow into colonies.

- Validation of DKK1 Knockout:
 - Genomic DNA Analysis:
 - Expand individual clones and extract genomic DNA.
 - PCR amplify the region of the DKK1 gene targeted by the gRNA.
 - Perform Sanger sequencing of the PCR products to identify insertions or deletions (indels) that result in a frameshift mutation.
 - Protein Level Validation:
 - Perform Western blot analysis on cell lysates from potential knockout clones to confirm the absence of DKK1 protein.
 - Alternatively, use an ELISA to measure the concentration of secreted DKK1 in the cell culture supernatant.
- Expansion and Banking of Validated Clones:
 - Expand the validated DKK1 knockout and scrambled control clones.
 - Cryopreserve stocks of the validated cell lines for future experiments.

Visualizations

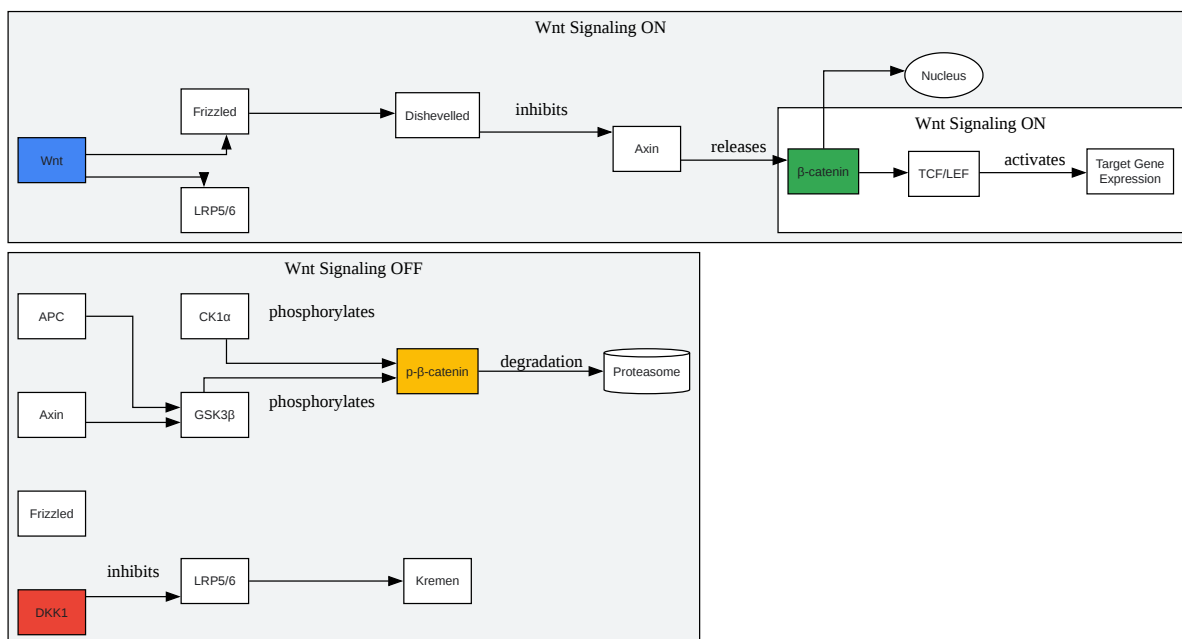

[Click to download full resolution via product page](#)

Caption: DKK1-mediated inhibition of Wnt/ β -catenin signaling.

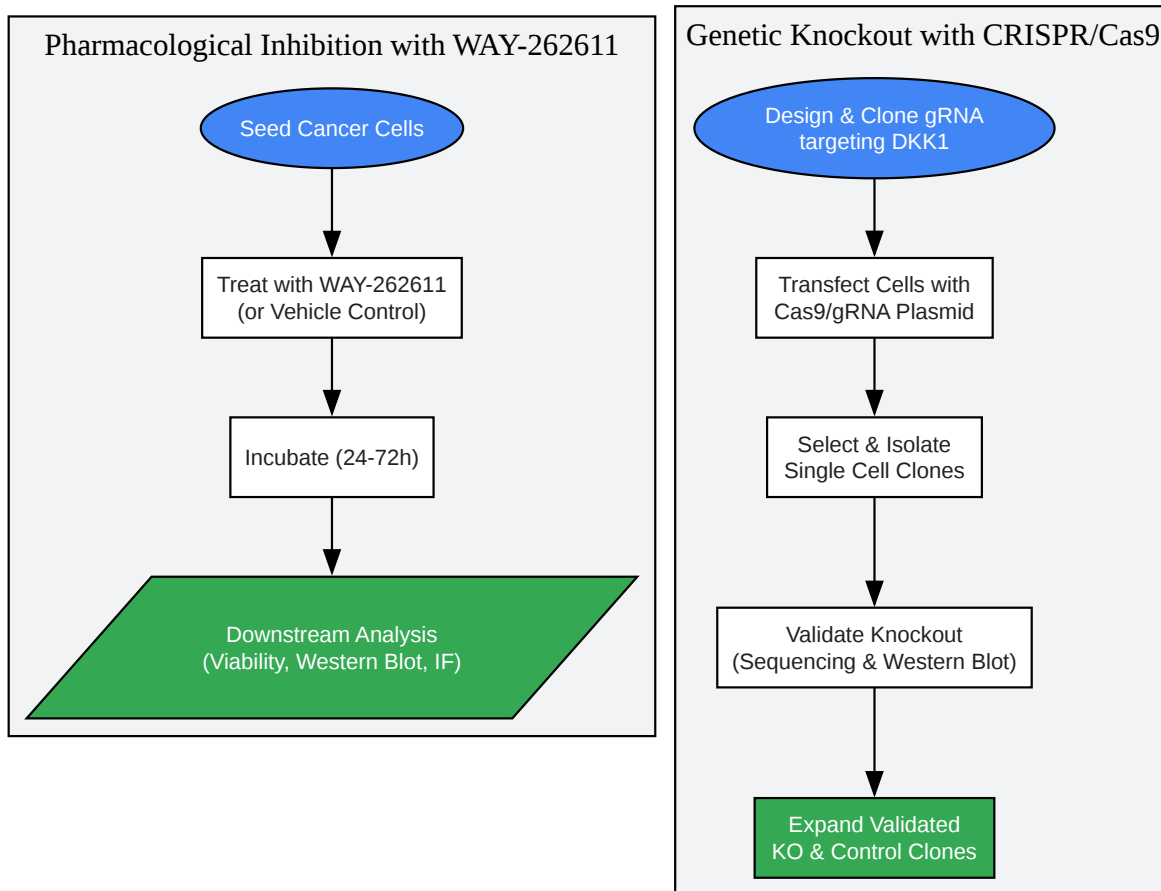

[Click to download full resolution via product page](#)

Caption: Experimental workflows for **WAY-262611** and CRISPR/Cas9 studies.

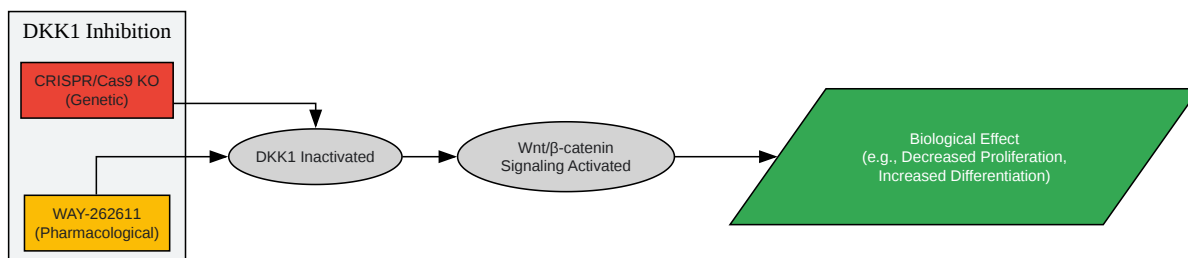

[Click to download full resolution via product page](#)

Caption: Logical relationship of DKK1 inhibition methods and outcomes.

Need Custom Synthesis?

BenchChem offers custom synthesis for rare earth carbides and specific isotopic labeling.

Email: info@benchchem.com or [Request Quote Online](#).

References

- 1. Standardized Relative Quantification of Immunofluorescence Tissue Staining [protocols.io]
- 2. Quantitative Procedure to Analyze Nuclear β-Catenin Using Immunofluorescence Tissue Staining [protocols.io]
- To cite this document: BenchChem. [Application Notes and Protocols: WAY-262611 and CRISPR/Cas9 DKK1 Knockout Studies]. BenchChem, [2025]. [Online PDF]. Available at: [<https://www.benchchem.com/product/b611799#way-262611-and-crispr-cas9-dkk1-knockout-studies>]

Disclaimer & Data Validity:

The information provided in this document is for Research Use Only (RUO) and is strictly not intended for diagnostic or therapeutic procedures. While BenchChem strives to provide

accurate protocols, we make no warranties, express or implied, regarding the fitness of this product for every specific experimental setup.

Technical Support: The protocols provided are for reference purposes. Unsure if this reagent suits your experiment? [[Contact our Ph.D. Support Team for a compatibility check](#)]

Need Industrial/Bulk Grade? [Request Custom Synthesis Quote](#)

BenchChem

Our mission is to be the trusted global source of essential and advanced chemicals, empowering scientists and researchers to drive progress in science and industry.

Contact

Address: 3281 E Guasti Rd

Ontario, CA 91761, United States

Phone: (601) 213-4426

Email: info@benchchem.com