

Application Notes and Protocols: Utilizing Telatinib Mesylate in Combination with Chemotherapy Agents

Author: BenchChem Technical Support Team. **Date:** December 2025

Compound of Interest

Compound Name: *Telatinib Mesylate*

Cat. No.: *B3424068*

[Get Quote](#)

For Researchers, Scientists, and Drug Development Professionals

These application notes provide a comprehensive overview of the preclinical and clinical rationale for combining **Telatinib Mesylate** with conventional chemotherapy agents. Detailed protocols for key experiments are included to facilitate further research and development in this area.

Introduction

Telatinib Mesylate is an orally bioavailable small-molecule inhibitor targeting multiple receptor tyrosine kinases, including Vascular Endothelial Growth Factor Receptors 2 and 3 (VEGFR-2/3), Platelet-Derived Growth Factor Receptor alpha (PDGFR α), and c-Kit.[1][2] These receptors are crucial mediators of tumor angiogenesis and cell proliferation.[1] The antiangiogenic properties of Telatinib, combined with its potential to reverse multidrug resistance, make it a compelling candidate for combination therapies with cytotoxic chemotherapy.

Mechanism of Action and Rationale for Combination Therapy

Telatinib exerts its anti-tumor effects through the inhibition of key signaling pathways involved in tumor growth and survival. By blocking VEGFR-2/3, Telatinib disrupts the formation of new

blood vessels, thereby limiting the supply of oxygen and nutrients to the tumor.[3][4] Inhibition of PDGFR α can impact tumor cell proliferation and the tumor microenvironment.[5][6] The blockade of c-Kit signaling is relevant in malignancies where this receptor is a key driver of oncogenesis.[7][8][9][10]

A significant aspect of Telatinib's potential in combination therapy lies in its ability to inhibit the ATP-binding cassette (ABC) transporter ABCG2.[11][12] ABCG2 is a key mediator of multidrug resistance (MDR) in cancer cells, actively effluxing a wide range of chemotherapeutic drugs and reducing their intracellular concentration and efficacy.[11][12] By inhibiting ABCG2, Telatinib can restore or enhance the sensitivity of cancer cells to conventional chemotherapy agents that are substrates of this transporter, such as doxorubicin and topotecan.[11][12]

Preclinical Data: Telatinib in Combination with Doxorubicin

A preclinical study by Sodani et al. investigated the synergistic effect of Telatinib and doxorubicin in a xenograft model of ABCG2-overexpressing tumors. The combination of Telatinib (15 mg/kg) and doxorubicin (1.8 mg/kg) resulted in a significant decrease in both tumor growth rate and final tumor size.[11][12]

Quantitative Data Summary: Preclinical

Parameter	Telatinib (15 mg/kg) + Doxorubicin (1.8 mg/kg)	Reference
In Vivo Tumor Growth	Significantly decreased growth rate and tumor size	[11][12]
Intracellular Drug Accumulation	Telatinib (1 μ M) significantly enhanced intracellular [3H]-mitoxantrone accumulation in ABCG2-overexpressing cells.	[11]
Drug Efflux	Telatinib (1 μ M) significantly reduced the efflux of [3H]-mitoxantrone from ABCG2-overexpressing cells.	[11]

Clinical Data: Telatinib in Combination with Capecitabine and Irinotecan

A Phase I clinical trial by Langenberg et al. evaluated the safety, tolerability, and preliminary efficacy of Telatinib in combination with capecitabine and irinotecan in patients with advanced solid tumors.[13][14] The study established a recommended Phase II dose and demonstrated anti-tumor activity in a heavily pretreated patient population.[13][14]

Quantitative Data Summary: Clinical

Dose Escalation Cohort	Telatinib Dose	Irinotecan Dose (mg/m ²)	Capecitabine Dose (mg/m ² twice daily)	Number of Patients	Key Grade 3/4 Toxicities	Response (Partial Remission / Stable Disease)
1	300 mg twice daily	125	1000	3	Diarrhea (1)	0 / 2
2	600 mg twice daily	125	1000	4	Diarrhea (1), Vomiting (1)	1 / 2
3	900 mg twice daily	125	1000	7	Diarrhea (2), Hand-foot syndrome (1)	2 / 3
4	900 mg twice daily	180	1000	9	Diarrhea (3), Neutropenia (2)	2 / 2
Total	23	5 / 9				

Data compiled from Langenberg et al., Clinical Cancer Research, 2010.[13][14]

Recommended Phase II Dose: Telatinib 900 mg twice daily continuously, combined with irinotecan 180 mg/m² every 3 weeks and capecitabine 1000 mg/m² twice daily on days 1-14 of a 21-day cycle.[13][14]

Experimental Protocols

In Vitro Cytotoxicity Assay (MTT Assay)

This protocol is adapted for determining the cytotoxic effects of Telatinib in combination with a chemotherapy agent.

Materials:

- Cancer cell line of interest (e.g., ABCG2-overexpressing and parental cells)
- Complete cell culture medium
- **Telatinib Mesylate**
- Chemotherapy agent (e.g., doxorubicin)
- MTT (3-(4,5-dimethylthiazol-2-yl)-2,5-diphenyltetrazolium bromide) solution (5 mg/mL in PBS)[15]
- Solubilization solution (e.g., DMSO or 0.01 N HCl in 10% SDS)[15]
- 96-well plates
- Microplate reader

Procedure:

- Seed cells in a 96-well plate at a predetermined optimal density and incubate overnight.[16][17][18]
- Prepare serial dilutions of Telatinib and the chemotherapy agent, both alone and in combination, in complete culture medium.

- Remove the overnight culture medium from the cells and add the drug-containing media. Include wells with untreated cells as a control.
- Incubate the plates for a specified period (e.g., 72 hours).[19]
- Add 10 μ L of MTT solution to each well and incubate for 2-4 hours at 37°C.[16]
- Add 100 μ L of solubilization solution to each well and mix thoroughly to dissolve the formazan crystals.[16]
- Measure the absorbance at 570 nm using a microplate reader.[15]
- Calculate the percentage of cell viability relative to the untreated control and determine IC50 values. Synergy can be assessed using methods such as the Combination Index (CI).[19][20][21]

Intracellular Drug Accumulation Assay

This protocol is designed to measure the effect of Telatinib on the intracellular accumulation of a fluorescent or radiolabeled chemotherapy drug that is an ABCG2 substrate.

Materials:

- ABCG2-overexpressing and parental cells
- **Telatinib Mesylate**
- Radiolabeled ABCG2 substrate (e.g., [³H]-mitoxantrone)[11][12]
- Ice-cold phosphate-buffered saline (PBS)
- Lysis buffer
- Scintillation counter and scintillation fluid

Procedure:

- Seed cells in multi-well plates and grow to confluence.

- Pre-incubate the cells with or without Telatinib at a specified concentration (e.g., 1 μ M) for a defined period (e.g., 1 hour) at 37°C.[11]
- Add the radiolabeled ABCG2 substrate to the wells and incubate for various time points.
- To terminate the assay, rapidly wash the cells three times with ice-cold PBS.
- Lyse the cells with lysis buffer.
- Measure the radioactivity in the cell lysates using a scintillation counter.
- Determine the protein concentration of the lysates to normalize the radioactivity counts.
- Compare the intracellular accumulation of the substrate in the presence and absence of Telatinib.

In Vivo Xenograft Study

This protocol outlines a general procedure for evaluating the in vivo efficacy of Telatinib in combination with a chemotherapy agent in a tumor xenograft model.

Materials:

- Immunocompromised mice (e.g., nude mice)
- Cancer cell line known to form tumors in mice (e.g., ABCG2-overexpressing cells)
- **Telatinib Mesylate** formulated for oral administration
- Chemotherapy agent formulated for administration (e.g., doxorubicin for intravenous or intraperitoneal injection)
- Calipers for tumor measurement

Procedure:

- Subcutaneously inject a suspension of cancer cells into the flank of each mouse.

- Monitor the mice for tumor growth. Once tumors reach a palpable size (e.g., 100-200 mm³), randomize the mice into treatment groups (e.g., vehicle control, Telatinib alone, chemotherapy alone, combination therapy).
- Administer Telatinib orally according to the desired dosing schedule (e.g., daily).
- Administer the chemotherapy agent according to its established protocol (e.g., once weekly). [\[11\]](#)
- Measure tumor dimensions with calipers at regular intervals (e.g., twice weekly) and calculate tumor volume (e.g., Volume = (length x width²)/2).
- Monitor the body weight of the mice as an indicator of toxicity.
- At the end of the study, euthanize the mice and excise the tumors for further analysis (e.g., weight, immunohistochemistry).
- Compare tumor growth inhibition among the different treatment groups.

Signaling Pathways and Experimental Workflows

Telatinib Mesylate Signaling Inhibition

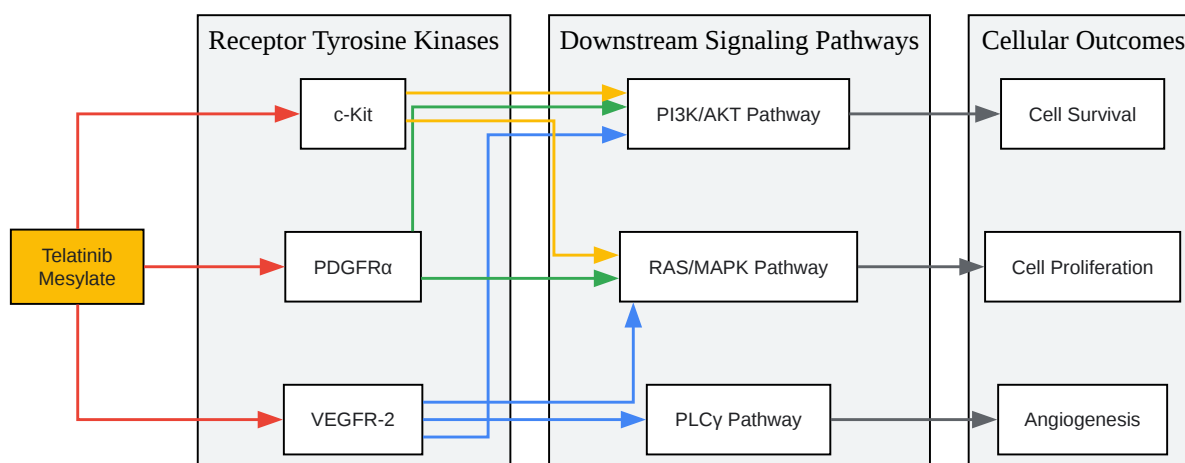

[Click to download full resolution via product page](#)

Caption: Telatinib inhibits VEGFR-2, PDGFR α , and c-Kit, blocking downstream signaling.

Synergistic Action of Telatinib and Doxorubicin

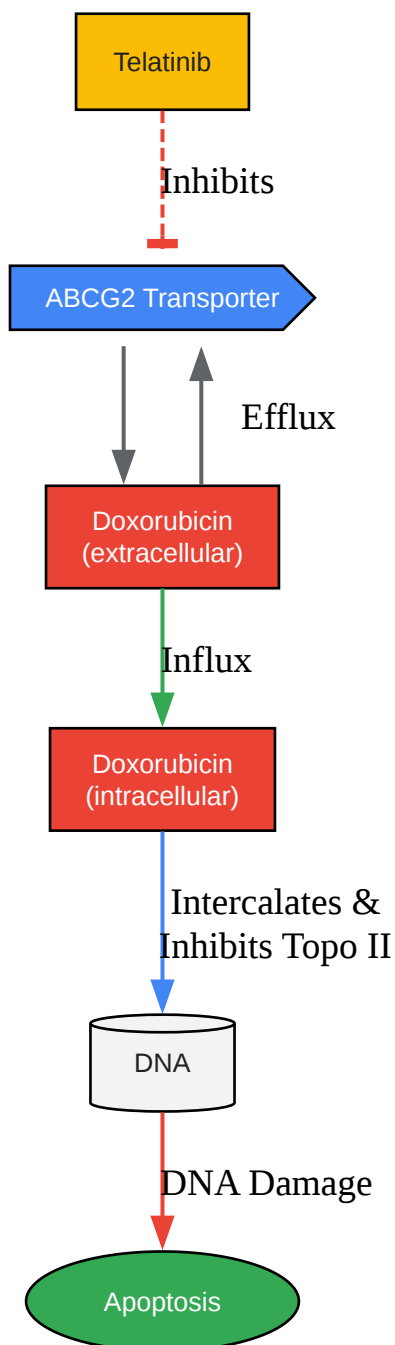

[Click to download full resolution via product page](#)

Caption: Telatinib enhances doxorubicin efficacy by inhibiting ABCG2-mediated efflux.

Combination Chemotherapy Experimental Workflow

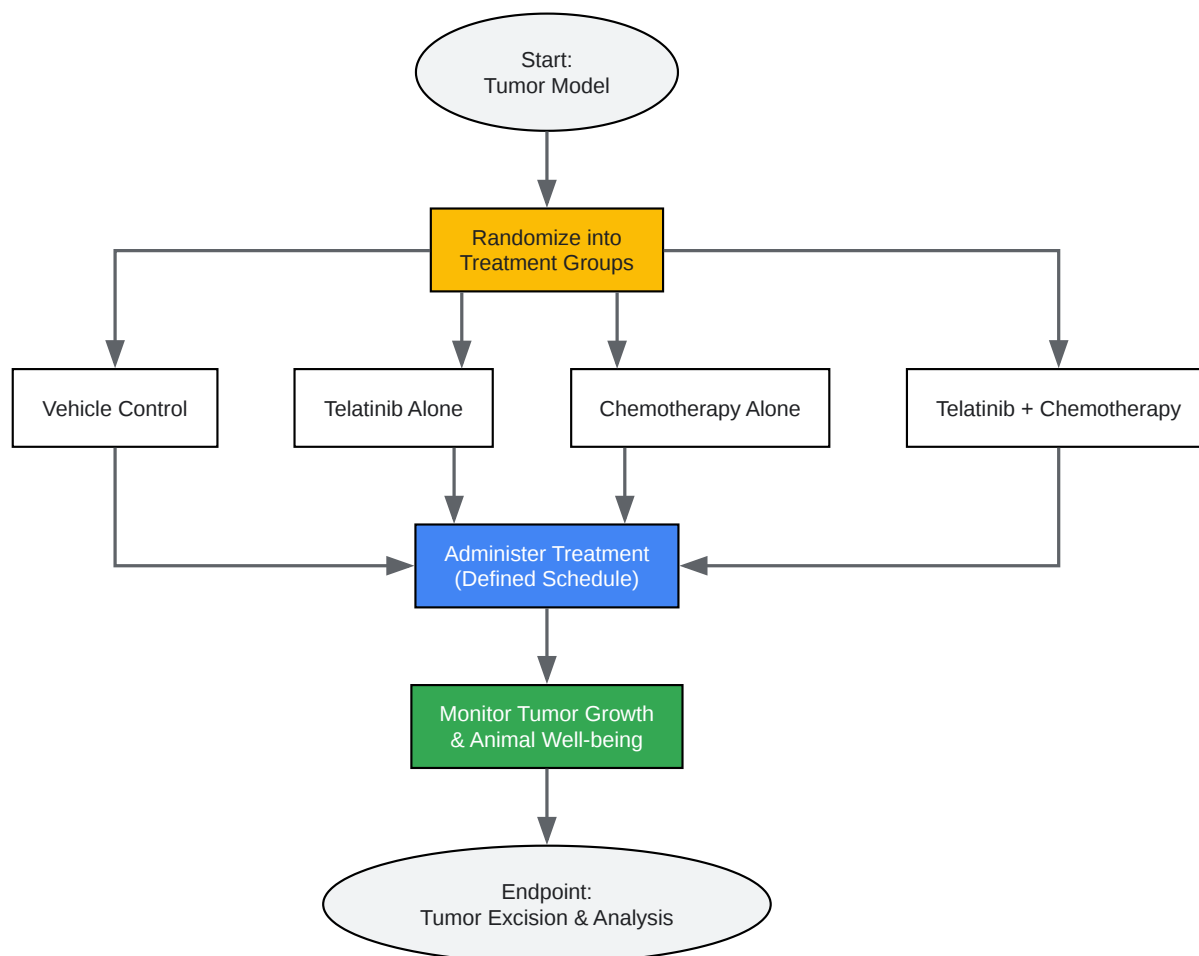

[Click to download full resolution via product page](#)

Caption: Workflow for in vivo evaluation of Telatinib and chemotherapy combination.

Conclusion

The combination of **Telatinib Mesylate** with conventional chemotherapy agents presents a promising therapeutic strategy. Its dual mechanism of inhibiting tumor angiogenesis and reversing multidrug resistance provides a strong rationale for further investigation. The

provided data and protocols offer a foundation for researchers to explore and validate the clinical potential of Telatinib-based combination therapies in various cancer types.

Need Custom Synthesis?

BenchChem offers custom synthesis for rare earth carbides and specific isotopic labeling.

Email: info@benchchem.com or [Request Quote Online](#).

References

- 1. Doxorubicin - Wikipedia [en.wikipedia.org]
- 2. researchgate.net [researchgate.net]
- 3. Modulation of VEGF Receptor 2 signaling by Protein Phosphatases - PMC [pmc.ncbi.nlm.nih.gov]
- 4. VEGF-A/VEGFR2 signaling network in endothelial cells relevant to angiogenesis - PMC [pmc.ncbi.nlm.nih.gov]
- 5. researchgate.net [researchgate.net]
- 6. Roles of PDGF/PDGFR signaling in various organs - PMC [pmc.ncbi.nlm.nih.gov]
- 7. researchgate.net [researchgate.net]
- 8. researchgate.net [researchgate.net]
- 9. C-KIT signaling in cancer treatment. | Semantic Scholar [semanticscholar.org]
- 10. The C-Kit Receptor-Mediated Signal Transduction and Tumor-Related Diseases - PMC [pmc.ncbi.nlm.nih.gov]
- 11. Telatinib reverses chemotherapeutic multidrug resistance mediated by ABCG2 efflux transporter in vitro and in vivo - PubMed [pubmed.ncbi.nlm.nih.gov]
- 12. Telatinib reverses chemotherapeutic multidrug resistance mediated by ABCG2 efflux transporter in vitro and in vivo - PMC [pmc.ncbi.nlm.nih.gov]
- 13. aacrjournals.org [aacrjournals.org]
- 14. Phase I evaluation of telatinib, a vascular endothelial growth factor receptor tyrosine kinase inhibitor, in combination with irinotecan and capecitabine in patients with advanced solid tumors - PubMed [pubmed.ncbi.nlm.nih.gov]
- 15. MTT assay protocol | Abcam [abcam.com]

- 16. Cell Viability Assays - Assay Guidance Manual - NCBI Bookshelf [ncbi.nlm.nih.gov]
- 17. texaschildrens.org [texaschildrens.org]
- 18. MTT Assay Protocol for Cell Viability and Proliferation [merckmillipore.com]
- 19. Methods for High-throughput Drug Combination Screening and Synergy Scoring - PMC [pmc.ncbi.nlm.nih.gov]
- 20. Quantitative Methods for Assessing Drug Synergism - PMC [pmc.ncbi.nlm.nih.gov]
- 21. Evaluation of synergism in drug combinations and reference models for future orientations in oncology - PMC [pmc.ncbi.nlm.nih.gov]
- To cite this document: BenchChem. [Application Notes and Protocols: Utilizing Telatinib Mesylate in Combination with Chemotherapy Agents]. BenchChem, [2025]. [Online PDF]. Available at: [https://www.benchchem.com/product/b3424068#using-telatinib-mesylate-in-combination-with-chemotherapy-agents]

Disclaimer & Data Validity:

The information provided in this document is for Research Use Only (RUO) and is strictly not intended for diagnostic or therapeutic procedures. While BenchChem strives to provide accurate protocols, we make no warranties, express or implied, regarding the fitness of this product for every specific experimental setup.

Technical Support: The protocols provided are for reference purposes. Unsure if this reagent suits your experiment? [[Contact our Ph.D. Support Team for a compatibility check](#)]

Need Industrial/Bulk Grade? [Request Custom Synthesis Quote](#)

BenchChem

Our mission is to be the trusted global source of essential and advanced chemicals, empowering scientists and researchers to drive progress in science and industry.

Contact

Address: 3281 E Guasti Rd
Ontario, CA 91761, United States
Phone: (601) 213-4426
Email: info@benchchem.com