

# Application Notes and Protocols: Utilizing MM-401 in MLL-rearranged Leukemia Cell Lines

**Author:** BenchChem Technical Support Team. **Date:** December 2025

## Compound of Interest

Compound Name: MM-401

Cat. No.: B15579438

[Get Quote](#)

Audience: Researchers, scientists, and drug development professionals.

## Introduction

Mixed-lineage leukemia (MLL)-rearranged (MLLr) leukemias are aggressive hematological malignancies with a generally poor prognosis, particularly in infants.[1][2] These leukemias are characterized by chromosomal translocations involving the KMT2A (MLL1) gene, leading to the expression of oncogenic MLL fusion proteins.[3][4] The catalytic activity of the wild-type MLL1 protein, a histone H3 lysine 4 (H3K4) methyltransferase, is crucial for the initiation and maintenance of MLLr leukemia.[5] **MM-401** is a potent and specific inhibitor of MLL1 methyltransferase activity.[5][6] These application notes provide a comprehensive overview and detailed protocols for the use of **MM-401** in MLL-rearranged leukemia cell lines.

## Mechanism of Action

**MM-401** functions by disrupting the critical protein-protein interaction between MLL1 and WD repeat-containing protein 5 (WDR5).[5][6] WDR5 is an essential component of the MLL1 core complex, and its interaction with MLL1 is required for the histone methyltransferase activity of the complex.[5][7][8][9] By binding to WDR5 with high affinity, **MM-401** competitively inhibits the binding of MLL1, leading to the disassembly of the MLL1 core complex and a subsequent reduction in H3K4 methylation at MLL1 target genes, such as HOXA9 and MEIS1.[5][10] This targeted inhibition of MLL1's catalytic activity selectively induces cell cycle arrest, apoptosis, and myeloid differentiation in MLL-rearranged leukemia cells, while sparing non-MLL leukemia cells and normal hematopoietic progenitors.[5]

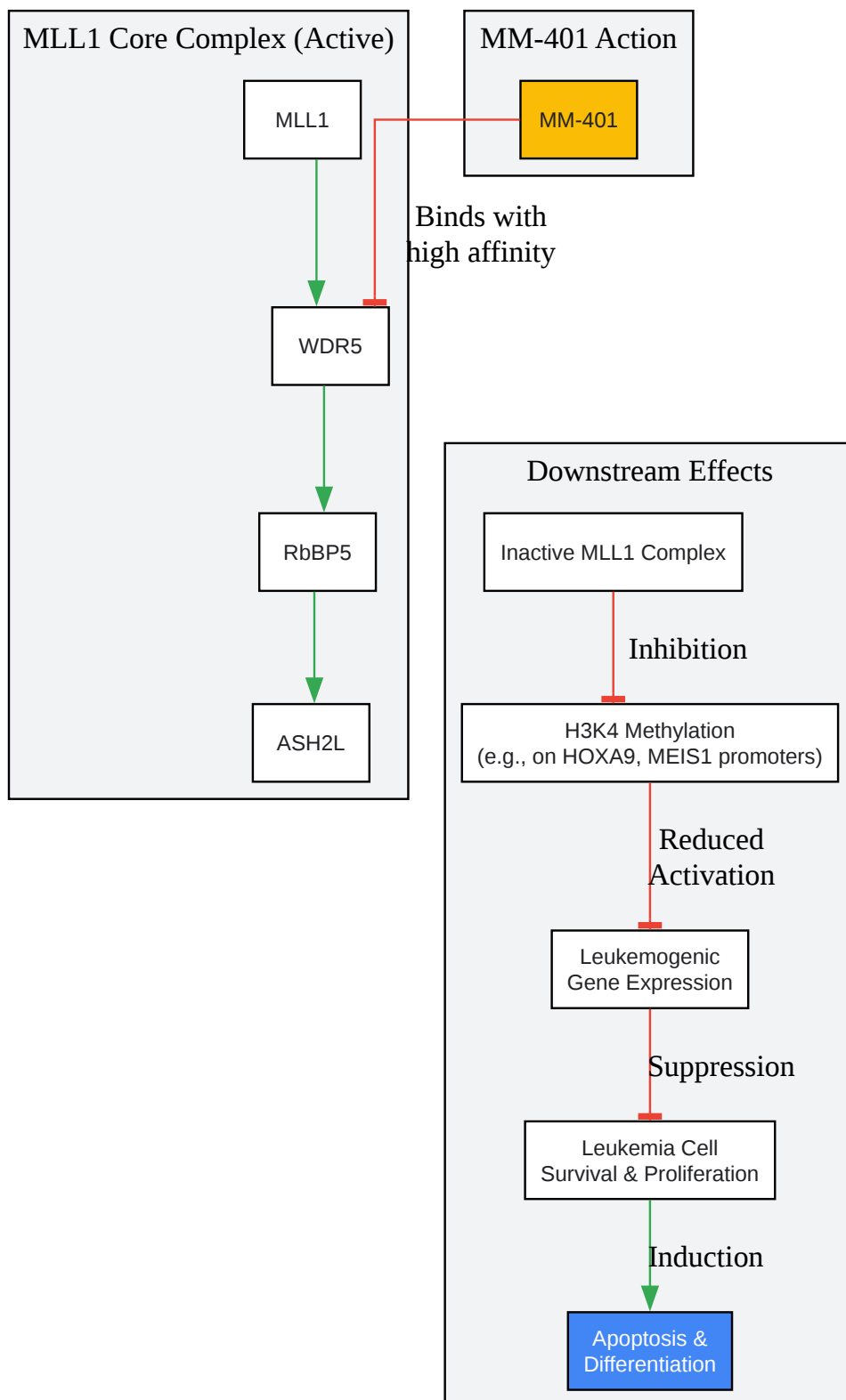

[Click to download full resolution via product page](#)

**Figure 1:** Mechanism of action of MM-401.

## Quantitative Data Summary

The following tables summarize the reported inhibitory concentrations of **MM-401** in various MLL-rearranged and non-MLL leukemia cell lines.

Table 1: In Vitro Inhibitory Activity of **MM-401**

Parameter	Target	Value	Reference
IC50	MLL1 H3K4 Methyltransferase Activity	0.32 $\mu$ M	[6]
IC50	WDR5-MLL1 Interaction	0.9 nM	[6][11]
Ki	WDR5 Binding Affinity	< 1 nM	[6]

Table 2: Growth Inhibition (GI50) of **MM-401** in Human MLL-rearranged Leukemia Cell Lines

Cell Line	MLL Fusion	GI50 ( $\mu$ M)
MV4;11	MLL-AF4	~10
MOLM13	MLL-AF9	~10
KOPN8	MLL-ENL	~10

Data compiled from a study by Cao et al., which states the GI50 value is approximately 10 $\mu$ M for MLL-AF9 cells and provides a figure showing similar efficacy in MV4;11, MOLM13, and KOPN8 cell lines.[5]

Table 3: Growth Inhibition (GI50) of **MM-401** in Murine MLL-rearranged Leukemia Cell Lines

Cell Line	Oncogenic Driver	GI50 ( $\mu\text{M}$ )
MLL-AF9	MLL-AF9	~10
MLL-ENL	MLL-ENL	~10
MLL-AF1	MLL-AF1	~10
Hoxa9/Meis1	Hoxa9/Meis1	No Inhibition

Data compiled from a study by Cao et al.[5]

## Experimental Protocols

Herein are detailed protocols for key experiments to assess the efficacy and mechanism of **MM-401** in MLL-rearranged leukemia cell lines.

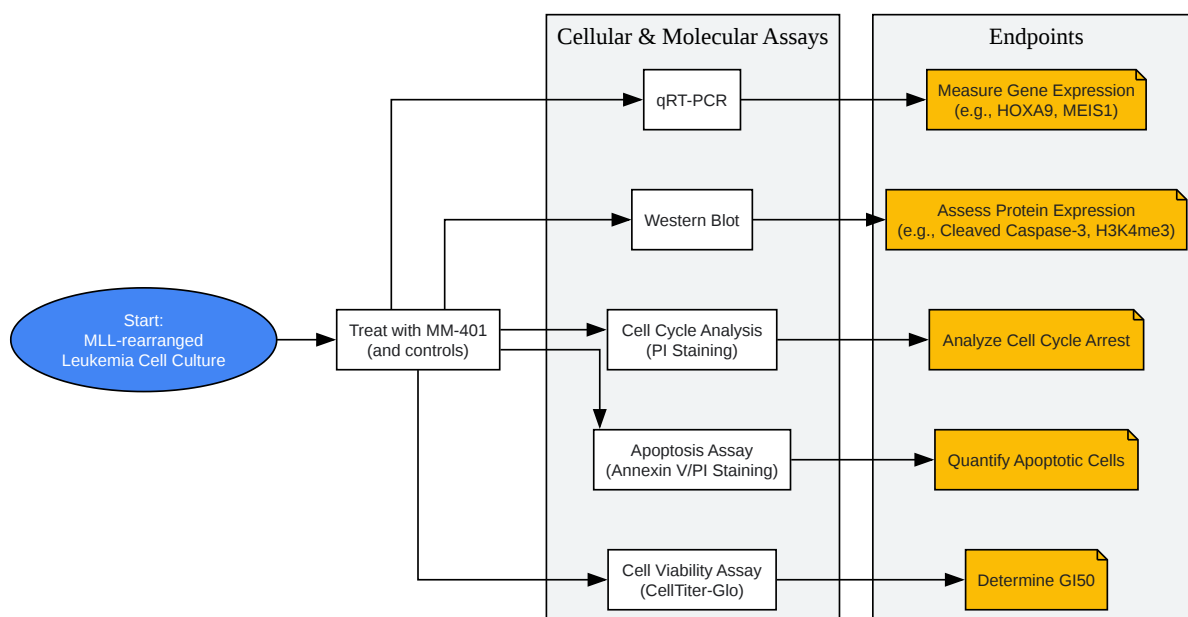

[Click to download full resolution via product page](#)

**Figure 2:** General experimental workflow.

## Cell Viability Assay (CellTiter-Glo®)

This protocol determines the number of viable cells in culture based on the quantification of ATP.

Materials:

- MLL-rearranged leukemia cell lines (e.g., MV4;11, MOLM13)
- RPMI-1640 medium with 10% FBS and 1% Penicillin-Streptomycin
- **MM-401** (and enantiomer control MM-NC-401)
- DMSO (vehicle control)
- Opaque-walled 96-well plates
- CellTiter-Glo® Luminescent Cell Viability Assay kit
- Luminometer

Procedure:

- Cell Seeding:
  - Culture MLL-rearranged leukemia cells to logarithmic growth phase.
  - Count the cells and adjust the density to  $1 \times 10^5$  cells/mL in fresh culture medium.
  - Seed 100  $\mu$ L of the cell suspension (10,000 cells) into each well of an opaque-walled 96-well plate.
  - Include wells with medium only for background measurement.
- Compound Treatment:

- Prepare serial dilutions of **MM-401** and the negative control MM-NC-401 in culture medium. A typical concentration range would be from 0.1  $\mu\text{M}$  to 50  $\mu\text{M}$ .
- Prepare a vehicle control (DMSO) at the same final concentration as in the highest **MM-401** concentration.
- Add the desired volume of the compound dilutions to the wells.
- Incubate the plate for 72 hours at 37°C in a 5% CO<sub>2</sub> incubator.
- Luminescence Measurement:
  - Equilibrate the plate to room temperature for approximately 30 minutes.[\[4\]](#)[\[12\]](#)[\[13\]](#)
  - Add 100  $\mu\text{L}$  of CellTiter-Glo® Reagent to each well.[\[12\]](#)[\[14\]](#)
  - Mix the contents on an orbital shaker for 2 minutes to induce cell lysis.[\[4\]](#)[\[13\]](#)
  - Incubate at room temperature for 10 minutes to stabilize the luminescent signal.[\[4\]](#)[\[13\]](#)
  - Measure the luminescence using a plate luminometer.
- Data Analysis:
  - Subtract the average background luminescence from all readings.
  - Normalize the data by expressing the luminescence of treated wells as a percentage of the vehicle-treated control wells.
  - Plot the percentage of cell viability against the logarithm of the compound concentration and determine the GI50 value using non-linear regression analysis.

## Apoptosis Assay (Annexin V and Propidium Iodide Staining)

This flow cytometry-based assay quantifies the percentage of apoptotic and necrotic cells following treatment with **MM-401**.

#### Materials:

- Treated and control MLL-rearranged leukemia cells
- Annexin V-FITC Apoptosis Detection Kit (or similar, containing Annexin V-FITC, Propidium Iodide (PI), and Binding Buffer)
- Phosphate-Buffered Saline (PBS)
- Flow cytometer

#### Procedure:

- Cell Preparation:
  - Treat cells with **MM-401** (e.g., 20  $\mu$ M and 40  $\mu$ M) and controls for 48 hours.
  - Harvest approximately  $1-5 \times 10^5$  cells by centrifugation at 300 x g for 5 minutes.
  - Wash the cells once with cold PBS and centrifuge again.[\[5\]](#)
- Staining:
  - Resuspend the cell pellet in 100  $\mu$ L of 1X Binding Buffer.
  - Add 5  $\mu$ L of Annexin V-FITC and 5  $\mu$ L of PI to the cell suspension.
  - Gently vortex the cells.
- Incubation:
  - Incubate the cells for 15 minutes at room temperature in the dark.[\[5\]](#)[\[11\]](#)
- Flow Cytometry Analysis:
  - Add 400  $\mu$ L of 1X Binding Buffer to each tube.[\[5\]](#)
  - Analyze the cells by flow cytometry within 1 hour.

- Use unstained, Annexin V-FITC only, and PI only stained cells for compensation and to set the quadrants.
- Healthy cells will be Annexin V-negative and PI-negative. Early apoptotic cells will be Annexin V-positive and PI-negative. Late apoptotic/necrotic cells will be Annexin V-positive and PI-positive.

## Cell Cycle Analysis (Propidium Iodide Staining)

This protocol is for analyzing the distribution of cells in different phases of the cell cycle using PI staining and flow cytometry.

Materials:

- Treated and control MLL-rearranged leukemia cells
- Cold 70% ethanol
- PBS
- PI staining solution (containing PI and RNase A)
- Flow cytometer

Procedure:

- Cell Fixation:
  - Treat cells with **MM-401** (e.g., 10, 20, 40  $\mu$ M) and controls for 48 hours.
  - Harvest approximately  $1 \times 10^6$  cells by centrifugation.
  - Wash the cells with cold PBS.
  - Resuspend the cell pellet in 1 mL of cold PBS.
  - While gently vortexing, add 4 mL of cold 70% ethanol dropwise to fix the cells.
  - Incubate at  $-20^{\circ}\text{C}$  for at least 2 hours (or overnight).



- Staining:
  - Centrifuge the fixed cells at a higher speed (e.g., 850 x g) for 5-10 minutes.
  - Discard the ethanol and wash the cell pellet with PBS.
  - Resuspend the pellet in 500  $\mu$ L of PI staining solution.
- Incubation:
  - Incubate for 30 minutes at room temperature in the dark.
- Flow Cytometry Analysis:
  - Analyze the samples on a flow cytometer.
  - Use a dot plot of PI-Area versus PI-Width to gate out doublets and aggregates.
  - Analyze the DNA content histogram to determine the percentage of cells in G0/G1, S, and G2/M phases of the cell cycle.

## Western Blotting

This protocol is for detecting changes in protein expression and post-translational modifications following **MM-401** treatment.

Materials:

- Treated and control MLL-rearranged leukemia cells
- RIPA lysis buffer supplemented with protease and phosphatase inhibitors
- BCA Protein Assay Kit
- SDS-PAGE gels, running buffer, and transfer buffer
- PVDF or nitrocellulose membrane
- Blocking buffer (e.g., 5% non-fat dry milk or BSA in TBST)

- Primary antibodies (e.g., anti-H3K4me3, anti-cleaved caspase-3, anti-PARP, anti-MLL1, anti-WDR5, anti- $\beta$ -actin as a loading control)
- HRP-conjugated secondary antibodies
- Chemiluminescent substrate
- Imaging system

Procedure:

- Protein Extraction:
  - Treat cells with **MM-401** for the desired time.
  - Harvest and wash the cells with cold PBS.
  - Lyse the cells in RIPA buffer on ice for 30 minutes.
  - Centrifuge at 14,000 x g for 15 minutes at 4°C to pellet cell debris.
  - Collect the supernatant (cell lysate) and determine the protein concentration using a BCA assay.
- SDS-PAGE and Protein Transfer:
  - Denature 20-30  $\mu$ g of protein per sample by boiling in Laemmli buffer.
  - Separate the proteins on an SDS-PAGE gel.
  - Transfer the separated proteins to a PVDF or nitrocellulose membrane.
- Immunoblotting:
  - Block the membrane in blocking buffer for 1 hour at room temperature.
  - Incubate the membrane with the primary antibody (diluted in blocking buffer) overnight at 4°C with gentle agitation.

- Wash the membrane three times for 10 minutes each with TBST.
- Incubate with the appropriate HRP-conjugated secondary antibody for 1 hour at room temperature.
- Wash the membrane again three times for 10 minutes each with TBST.
- Detection:
  - Incubate the membrane with a chemiluminescent substrate.
  - Capture the signal using an imaging system.
  - Quantify the band intensities and normalize to the loading control.

## Quantitative Reverse Transcription PCR (qRT-PCR)

This protocol is for measuring the mRNA expression levels of MLL1 target genes.

Materials:

- Treated and control MLL-rearranged leukemia cells
- RNA extraction kit (e.g., RNeasy Kit)
- cDNA synthesis kit
- SYBR Green or TaqMan master mix
- Primers for target genes (HOXA9, MEIS1) and a housekeeping gene (GAPDH or ACTB)
- qPCR instrument

Procedure:

- RNA Extraction and cDNA Synthesis:
  - Treat cells with **MM-401** (e.g., 20  $\mu$ M) for 48 hours.

- Extract total RNA from the cells using an RNA extraction kit according to the manufacturer's instructions.
- Synthesize cDNA from 1-2 µg of total RNA using a cDNA synthesis kit.
- qPCR:
  - Set up the qPCR reaction by mixing cDNA, forward and reverse primers for the gene of interest, and SYBR Green/TaqMan master mix.
  - Run the qPCR reaction in a thermal cycler with appropriate cycling conditions.
- Data Analysis:
  - Determine the cycle threshold (Ct) values for each gene.
  - Calculate the relative gene expression using the  $\Delta\Delta C_t$  method, normalizing the expression of the target genes to the housekeeping gene.

### *Need Custom Synthesis?*

*BenchChem offers custom synthesis for rare earth carbides and specific isotopic labeling.*

*Email: [info@benchchem.com](mailto:info@benchchem.com) or [Request Quote Online](#).*

## References

- 1. [bio-rad-antibodies.com](https://www.bio-rad-antibodies.com) [[bio-rad-antibodies.com](https://www.bio-rad-antibodies.com)]
- 2. [promega.com](https://www.promega.com) [[promega.com](https://www.promega.com)]
- 3. [vet.cornell.edu](https://vet.cornell.edu) [[vet.cornell.edu](https://vet.cornell.edu)]
- 4. [scribd.com](https://www.scribd.com) [[scribd.com](https://www.scribd.com)]
- 5. [bosterbio.com](https://www.bosterbio.com) [[bosterbio.com](https://www.bosterbio.com)]
- 6. Protocol for Apoptosis Assay by Flow Cytometry Using Annexin V Staining Method - PMC [[pmc.ncbi.nlm.nih.gov](https://pubmed.ncbi.nlm.nih.gov)]
- 7. WDR5 Interacts with Mixed Lineage Leukemia (MLL) Protein via the Histone H3-binding Pocket - PMC [[pmc.ncbi.nlm.nih.gov](https://pubmed.ncbi.nlm.nih.gov)]

- 8. uniprot.org [uniprot.org]
- 9. Analysis of the Binding of Mixed Lineage Leukemia 1 (MLL1) and Histone 3 Peptides to WD Repeat Domain 5 (WDR5) for the Design of Inhibitors of the MLL1–WDR5 Interaction - PMC [pmc.ncbi.nlm.nih.gov]
- 10. Direct and Indirect Targeting of HOXA9 Transcription Factor in Acute Myeloid Leukemia | MDPI [mdpi.com]
- 11. kumc.edu [kumc.edu]
- 12. benchchem.com [benchchem.com]
- 13. Cell Viability Assays - Assay Guidance Manual - NCBI Bookshelf [ncbi.nlm.nih.gov]
- 14. CellTiter-Glo® Luminescent Cell Viability Assay Protocol [promega.com]
- To cite this document: BenchChem. [Application Notes and Protocols: Utilizing MM-401 in MLL-rearranged Leukemia Cell Lines]. BenchChem, [2025]. [Online PDF]. Available at: [https://www.benchchem.com/product/b15579438#using-mm-401-in-ml-1-rearranged-leukemia-cell-lines]

---

### Disclaimer & Data Validity:

The information provided in this document is for Research Use Only (RUO) and is strictly not intended for diagnostic or therapeutic procedures. While BenchChem strives to provide accurate protocols, we make no warranties, express or implied, regarding the fitness of this product for every specific experimental setup.

**Technical Support:** The protocols provided are for reference purposes. Unsure if this reagent suits your experiment? [[Contact our Ph.D. Support Team for a compatibility check](#)]

**Need Industrial/Bulk Grade?** [Request Custom Synthesis Quote](#)

## BenchChem

Our mission is to be the trusted global source of essential and advanced chemicals, empowering scientists and researchers to drive progress in science and industry.

### Contact

Address: 3281 E Guasti Rd  
Ontario, CA 91761, United States  
Phone: (601) 213-4426  
Email: [info@benchchem.com](mailto:info@benchchem.com)

