

Application Notes and Protocols: Tris-Based Buffer Systems in Native Gel Electrophoresis

Author: BenchChem Technical Support Team. **Date:** December 2025

Compound of Interest

Compound Name: *Tris succinate*

Cat. No.: *B3430625*

[Get Quote](#)

For Researchers, Scientists, and Drug Development Professionals

Introduction

Native gel electrophoresis is a powerful technique for the separation and analysis of proteins and protein complexes in their folded, active state. The choice of buffer system is critical for maintaining the native conformation and activity of the target molecules. While a specific "Tris-succinate" buffer system for native polyacrylamide gel electrophoresis (PAGE) is not widely documented in standard laboratory protocols, Tris-based buffer systems are fundamental to this technique. This document provides detailed application notes and protocols for the two most common Tris-based systems: Tris-Glycine and Bis-Tris.

Furthermore, it will detail a key application of succinate in the context of native PAGE: its use as a substrate for in-gel activity assays of mitochondrial Complex II (Succinate Dehydrogenase). This application is crucial for researchers studying mitochondrial function and related diseases.

I. Tris-Based Native PAGE Systems: An Overview

Tris (tris(hydroxymethyl)aminomethane) is a common buffering agent in electrophoresis due to its pKa of approximately 8.1 at 25°C, which is suitable for maintaining a stable pH in the physiological range.[1] In native PAGE, Tris is typically paired with a trailing ion, such as glycine or tricine, to create a discontinuous buffer system that facilitates protein stacking and separation.

Key Applications of Tris-Based Native PAGE:

- Analysis of protein-protein interactions.
- Determination of protein oligomeric state.
- Assessment of protein purity and integrity under non-denaturing conditions.
- Separation of protein isoforms.
- Enzyme activity assays following electrophoretic separation.
- Analysis of mitochondrial protein complexes.[\[2\]](#)[\[3\]](#)

Comparison of Common Tris-Based Native PAGE Systems

Feature	Tris-Glycine System	Bis-Tris System
Operating pH	Alkaline (pH 8.3-9.5)	Neutral (pH ~7.5)
Key Advantage	Widely used, cost-effective. [4]	Minimizes protein modifications, sharper bands. [5]
Best Suited For	Robust, general-purpose native protein separation.	Proteins sensitive to high pH, high-resolution analysis.
Trailing Ion	Glycine	MOPS or MES

II. Experimental Protocols

A. Tris-Glycine Native PAGE

This system utilizes a discontinuous buffer system with a higher pH, which is effective for the separation of a broad range of proteins.[\[4\]](#)

1. Buffer and Reagent Preparation

Buffer/Reagent	Stock Concentration	Recipe for 1 L	Storage
Resolving Gel Buffer	1.5 M Tris-HCl, pH 8.8	181.71 g Tris base, adjust pH with HCl, bring to 1 L with deionized water.	4°C
Stacking Gel Buffer	0.5 M Tris-HCl, pH 6.8	60.57 g Tris base, adjust pH with HCl, bring to 1 L with deionized water.	4°C
Running Buffer	10X (250 mM Tris, 1.92 M Glycine)	30.3 g Tris base, 144.1 g Glycine, bring to 1 L with deionized water. Do not adjust pH.	Room Temperature
Sample Buffer	2X	1.25 mL 0.5 M Tris-HCl, pH 6.8, 4 mL Glycerol, 0.2 mL 1% Bromophenol Blue, 4.75 mL deionized water.	4°C
Acrylamide/Bis-acrylamide	30% (29:1 or 37.5:1)	Commercially available.	4°C, protected from light
Ammonium Persulfate (APS)	10% (w/v)	1 g APS in 10 mL deionized water. Prepare fresh.	4°C (for a few days)
TEMED	N/A	Commercially available.	Room Temperature

2. Gel Casting

- Resolving Gel (e.g., 10%): For 10 mL, mix 3.33 mL of 30% Acrylamide/Bis-acrylamide, 2.5 mL of 1.5 M Tris-HCl, pH 8.8, and 4.07 mL of deionized water. Add 100 µL of 10% APS and

10 μ L of TEMED. Swirl to mix and pour immediately. Overlay with water or isopropanol. Allow to polymerize for 30-60 minutes.

- Stacking Gel (4%): For 5 mL, mix 0.67 mL of 30% Acrylamide/Bis-acrylamide, 1.25 mL of 0.5 M Tris-HCl, pH 6.8, and 3.0 mL of deionized water. Add 50 μ L of 10% APS and 5 μ L of TEMED. Swirl to mix, pour over the resolving gel after removing the overlay, and insert the comb. Allow to polymerize for 30-60 minutes.

3. Sample Preparation and Electrophoresis

- Mix protein samples with an equal volume of 2X Native PAGE Sample Buffer. Do not heat the samples.
- Assemble the gel cassette in the electrophoresis tank and fill the inner and outer chambers with 1X Tris-Glycine Running Buffer.
- Load the samples into the wells.
- Run the gel at a constant voltage (e.g., 100-150 V) until the dye front reaches the bottom of the gel. Keep the apparatus cool to prevent protein denaturation.

B. Bis-Tris Native PAGE (Blue Native PAGE)

This system operates at a near-neutral pH, which is advantageous for maintaining the stability and activity of protein complexes, particularly membrane proteins.[5] Coomassie Blue G-250 is often included in the cathode buffer and sample to impart a negative charge on the proteins for migration.[6]

1. Buffer and Reagent Preparation

Buffer/Reagent	Stock Concentration	Recipe for 1 L	Storage
Anode Buffer	1X (50 mM Bis-Tris, pH 7.0)	10.46 g Bis-Tris, adjust pH with HCl, bring to 1 L with deionized water.	4°C
Cathode Buffer (Dark Blue)	1X (50 mM Tricine, 15 mM Bis-Tris, 0.02% Coomassie G-250)	8.96 g Tricine, 3.14 g Bis-Tris, 0.2 g Coomassie G-250, bring to 1 L with deionized water. Adjust pH to 7.0.	4°C
Cathode Buffer (Light Blue)	1X (50 mM Tricine, 15 mM Bis-Tris, 0.002% Coomassie G-250)	8.96 g Tricine, 3.14 g Bis-Tris, 0.02 g Coomassie G-250, bring to 1 L with deionized water. Adjust pH to 7.0.	4°C
Sample Buffer	4X (200 mM Bis-Tris, pH 7.0, 40% Glycerol, 0.04% Bromophenol Blue)	41.8 g Bis-Tris, 400 mL Glycerol, 0.4 g Bromophenol Blue, adjust pH to 7.0, bring to 1 L with deionized water.	4°C
G-250 Sample Additive	5% (w/v)	5 g Coomassie G-250 in 100 mL deionized water.	Room Temperature
Acrylamide/Bis-acrylamide	30% or 40%	Commercially available.	4°C, protected from light

2. Gel Casting (Gradient Gels are common)

Precast gradient gels (e.g., 4-16%) are often used for Bis-Tris native PAGE to resolve a wide range of molecular weights. If casting your own, a gradient maker is required.

3. Sample Preparation and Electrophoresis

- For samples containing detergent, add the 5% G-250 Sample Additive to a final concentration that is one-fourth of the detergent concentration.
- Mix your sample with 4X Sample Buffer and the G-250 additive. Do not heat.
- Assemble the precast or hand-cast gel in the electrophoresis apparatus.
- Fill the inner (cathode) chamber with Dark Blue Cathode Buffer and the outer (anode) chamber with Anode Buffer.
- Load samples and run the gel at 150 V for approximately 90-120 minutes.
- For applications like Western blotting, it is recommended to replace the Dark Blue Cathode Buffer with the Light Blue Cathode Buffer after the dye front has migrated about one-third of the way down the gel to reduce background.

III. Application of Succinate in Native PAGE: In-Gel Activity Assay for Complex II

Following separation by native PAGE, the enzymatic activity of specific proteins can be assessed directly within the gel. Succinate is used as a substrate to specifically measure the activity of mitochondrial Complex II (Succinate Dehydrogenase).

Protocol for In-Gel Complex II Activity Staining

- Following native PAGE, rinse the gel briefly in deionized water.
- Incubate the gel in a freshly prepared staining solution.
- Staining Solution (for 10 mL):
 - 50 μ L of 1 M Tris-HCl, pH 7.4 (final concentration 5 mM)
 - 200 μ L of 1 M Sodium Succinate (final concentration 20 mM)
 - 2.5 mg Nitrotetrazolium Blue (NTB)

- 8 μ L of 250 mM Phenazine Methosulfate (PMS)
- Bring to 10 mL with deionized water.[2]
- Incubate the gel in the staining solution at room temperature, protected from light.
- The appearance of a dark blue/purple precipitate (formazan) indicates the location of active Complex II.
- Stop the reaction by washing the gel extensively with deionized water once the desired band intensity is reached.

IV. Visualizations

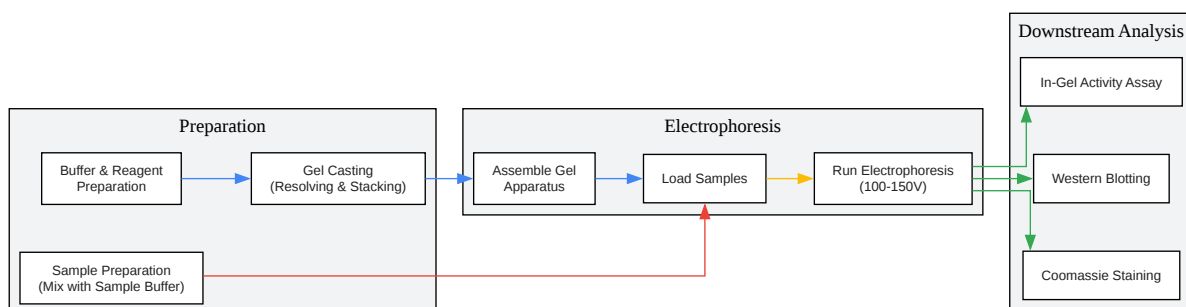

[Click to download full resolution via product page](#)

Caption: Workflow for Tris-Glycine Native PAGE.

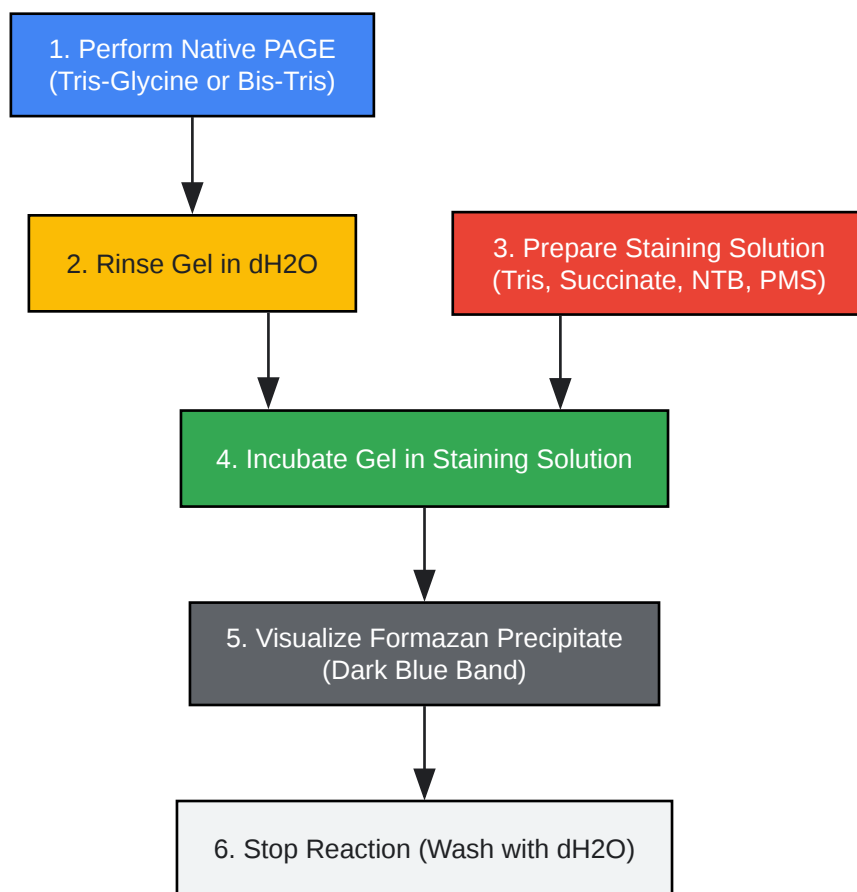

[Click to download full resolution via product page](#)

Caption: Workflow for In-Gel Succinate Dehydrogenase Activity Assay.

Need Custom Synthesis?

BenchChem offers custom synthesis for rare earth carbides and specific isotopic labeling.

Email: info@benchchem.com or [Request Quote Online](#).

References

- 1. nbinno.com [nbinno.com]
- 2. Analysis of mitochondrial respiratory chain supercomplexes using blue native polyacrylamide gel electrophoresis (BN-PAGE) - PMC [pmc.ncbi.nlm.nih.gov]
- 3. Respiratory supercomplexes act as a platform for complex III-mediated maturation of human mitochondrial complexes I and IV - PMC [pmc.ncbi.nlm.nih.gov]

- 4. docs.abcam.com [docs.abcam.com]
- 5. Tris Buffer (1 M, pH 7.2) Preparation and Recipe | AAT Bioquest [aatbio.com]
- 6. Native PAGE Gels | Thermo Fisher Scientific - SG [thermofisher.com]
- To cite this document: BenchChem. [Application Notes and Protocols: Tris-Based Buffer Systems in Native Gel Electrophoresis]. BenchChem, [2025]. [Online PDF]. Available at: [https://www.benchchem.com/product/b3430625#tris-succinate-in-native-gel-electrophoresis]

Disclaimer & Data Validity:

The information provided in this document is for Research Use Only (RUO) and is strictly not intended for diagnostic or therapeutic procedures. While BenchChem strives to provide accurate protocols, we make no warranties, express or implied, regarding the fitness of this product for every specific experimental setup.

Technical Support: The protocols provided are for reference purposes. Unsure if this reagent suits your experiment? [[Contact our Ph.D. Support Team for a compatibility check](#)]

Need Industrial/Bulk Grade? [Request Custom Synthesis Quote](#)

BenchChem

Our mission is to be the trusted global source of essential and advanced chemicals, empowering scientists and researchers to drive progress in science and industry.

Contact

Address: 3281 E Guasti Rd
Ontario, CA 91761, United States
Phone: (601) 213-4426
Email: info@benchchem.com