

# Application Notes and Protocols: Transwell Invasion Assay with Berberine Treatment

**Author:** BenchChem Technical Support Team. **Date:** December 2025

## Compound of Interest

Compound Name: Wilfordine

Cat. No.: B1197929

[Get Quote](#)

## For Researchers, Scientists, and Drug Development Professionals

These application notes provide a detailed protocol for assessing the anti-invasive properties of Berberine, a natural isoquinoline alkaloid, on cancer cells using a Transwell invasion assay. Berberine has been shown to inhibit cancer cell invasion by modulating key signaling pathways involved in metastasis.

## Introduction

Cancer cell invasion is a critical step in the metastatic cascade, allowing tumor cells to penetrate the basement membrane and surrounding tissues. The Transwell invasion assay, also known as the Boyden chamber assay, is a widely used in vitro method to quantify the invasive potential of cancer cells. This assay utilizes a two-chamber system separated by a porous membrane coated with a reconstituted basement membrane matrix, such as Matrigel™. Invasive cells degrade and migrate through this matrix towards a chemoattractant in the lower chamber.

Berberine has demonstrated significant anti-cancer effects, including the inhibition of cell invasion and metastasis.<sup>[1][2][3][4]</sup> Its mechanism of action involves the suppression of matrix metalloproteinases (MMPs), key enzymes responsible for extracellular matrix degradation, and the reversal of the epithelial-mesenchymal transition (EMT), a process that endows cancer cells with migratory and invasive capabilities.<sup>[3][5][6]</sup> Furthermore, Berberine has been shown

to modulate critical signaling pathways implicated in cancer progression, including the PI3K/Akt and MAPK pathways.<sup>[7][8][9][10][11]</sup>

This document provides a comprehensive protocol for conducting a Transwell invasion assay to evaluate the inhibitory effects of Berberine on cancer cell invasion.

## Data Presentation

The following table summarizes quantitative data from representative studies on the effect of Berberine on cancer cell invasion.

Cancer Cell Line	Berberine Concentration ( $\mu\text{M}$ )	Incubation Time (h)	Percent Inhibition of Invasion (%)	Reference
T24 (Bladder Cancer)	10, 20, 40	24	Dose-dependent decrease	[12]
SW620 (Colorectal Cancer)	10, 20, 40	48	Dose-dependent decrease	[13]
LoVo (Colorectal Cancer)	10, 20, 40	48	Dose-dependent decrease	[13]
HCT116 (Colorectal Cancer)	Not specified	Not specified	Significant decrease	[14]
SW480 (Colorectal Cancer)	Not specified	Not specified	Significant decrease	[14]
A549 (Lung Cancer)	5, 10, 20	24	Dose-dependent decrease	[15]
HepG2 (Liver Cancer)	Not specified	Not specified	Significant decrease	[6]
MGC803 (Gastric Cancer)	Not specified	Not specified	Dose-dependent decrease	[6]
SGC7901 (Gastric Cancer)	Not specified	Not specified	Dose-dependent decrease	[6]

## Experimental Protocols

### Transwell Invasion Assay Protocol

This protocol is a generalized guideline and should be optimized for specific cell lines and experimental conditions.

#### Materials:

- Cancer cell line of interest
- Berberine (dissolved in a suitable solvent, e.g., DMSO)
- Complete cell culture medium
- Serum-free cell culture medium
- Fetal Bovine Serum (FBS) as a chemoattractant
- Transwell inserts (8  $\mu\text{m}$  pore size) for 24-well plates
- Matrigel™ Basement Membrane Matrix
- Cold, serum-free medium
- Phosphate-Buffered Saline (PBS)
- Cotton swabs
- Fixation solution (e.g., 4% paraformaldehyde or methanol)
- Staining solution (e.g., 0.5% Crystal Violet in 25% methanol)
- Microscope

#### Procedure:

- Coating of Transwell Inserts:
  - Thaw Matrigel™ on ice overnight.
  - Dilute Matrigel™ with cold, serum-free medium to the desired concentration (typically 0.5-1 mg/mL). The optimal concentration should be determined empirically for each cell line.
  - Add 100  $\mu\text{L}$  of the diluted Matrigel™ solution to the upper chamber of each Transwell insert.

- Incubate the plates at 37°C for 4-6 hours to allow the gel to solidify.
- Cell Preparation:
  - Culture cancer cells to 70-80% confluency.
  - The day before the assay, serum-starve the cells by replacing the complete medium with serum-free medium. This enhances the chemoattractant response.
  - On the day of the assay, harvest the cells using trypsin-EDTA and resuspend them in serum-free medium.
  - Perform a cell count and adjust the cell suspension to the desired concentration (e.g.,  $1 \times 10^5$  cells/mL). The optimal cell number should be determined for each cell line.
- Assay Setup:
  - In the lower chamber of the 24-well plate, add 600  $\mu$ L of complete medium containing 10% FBS (chemoattractant).
  - In the upper chamber (the Transwell insert), add 200  $\mu$ L of the cell suspension in serum-free medium.
  - To the cell suspension in the upper chamber, add different concentrations of Berberine (e.g., 0, 10, 20, 40  $\mu$ M). Include a vehicle control (e.g., DMSO) corresponding to the highest concentration of the solvent used.
- Incubation:
  - Incubate the plate at 37°C in a humidified incubator with 5% CO<sub>2</sub> for 24-48 hours. The incubation time should be optimized based on the invasive capacity of the cell line.
- Fixation and Staining:
  - After incubation, carefully remove the medium from the upper chamber.
  - Using a cotton swab, gently remove the non-invaded cells and the Matrigel™ from the upper surface of the membrane.

- Fix the invaded cells on the lower surface of the membrane by immersing the inserts in a fixation solution for 20 minutes at room temperature.
- Wash the inserts with PBS.
- Stain the invaded cells by immersing the inserts in a staining solution for 15-20 minutes.
- Gently wash the inserts with water to remove excess stain and allow them to air dry.
- Quantification:
  - Visualize the stained, invaded cells using an inverted microscope.
  - Count the number of invaded cells in several random fields of view (e.g., 5-10 fields) for each insert.
  - Calculate the average number of invaded cells per field.
  - Alternatively, the stain can be eluted (e.g., with 10% acetic acid), and the absorbance can be measured using a plate reader.

## Mandatory Visualizations

### Signaling Pathways

The following diagrams illustrate the key signaling pathways involved in cancer cell invasion and how Berberine may exert its inhibitory effects.

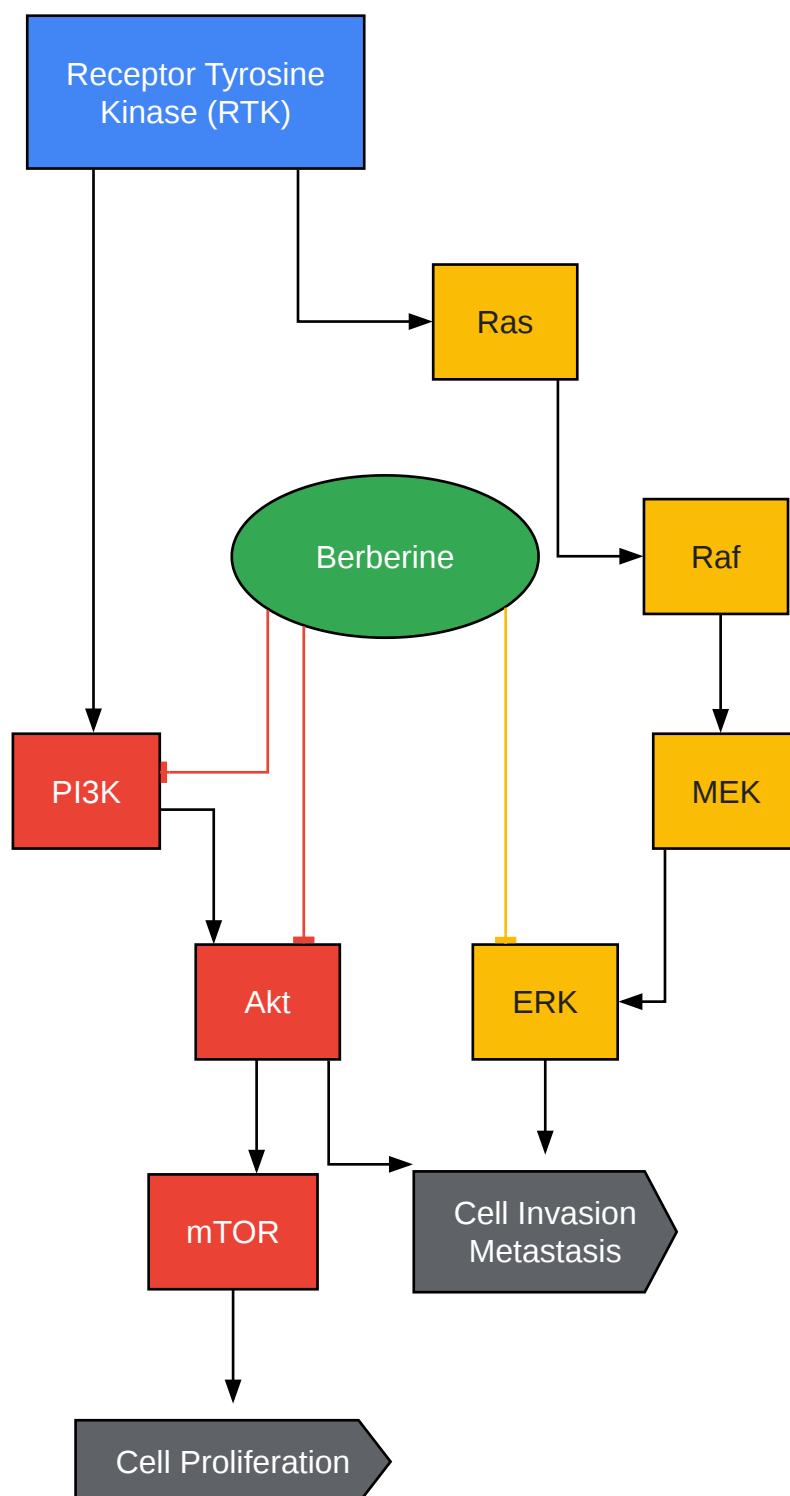

[Click to download full resolution via product page](#)

Berberine inhibits the PI3K/Akt and MAPK signaling pathways.

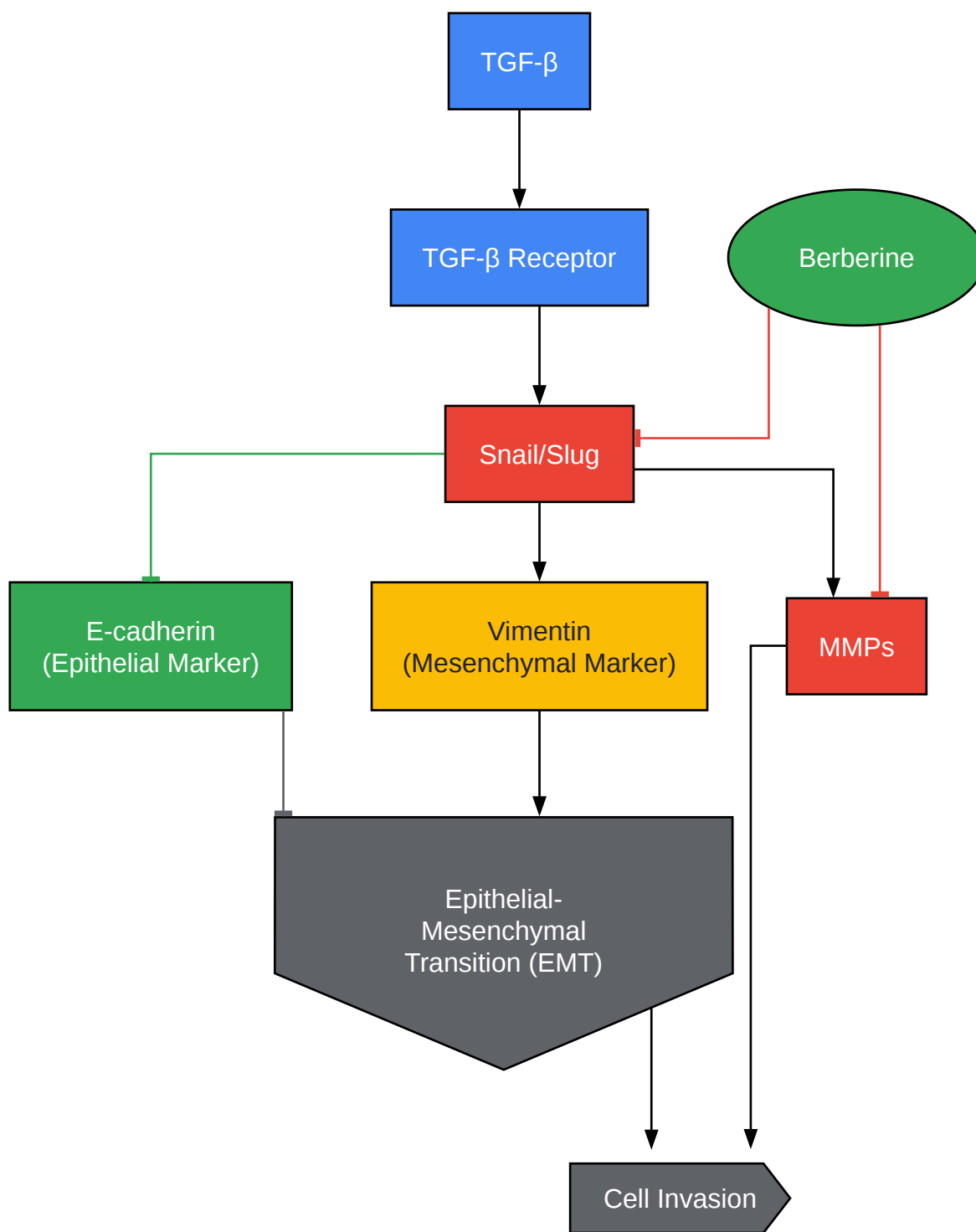

[Click to download full resolution via product page](#)

Berberine suppresses EMT and MMPs to inhibit invasion.

## Experimental Workflow



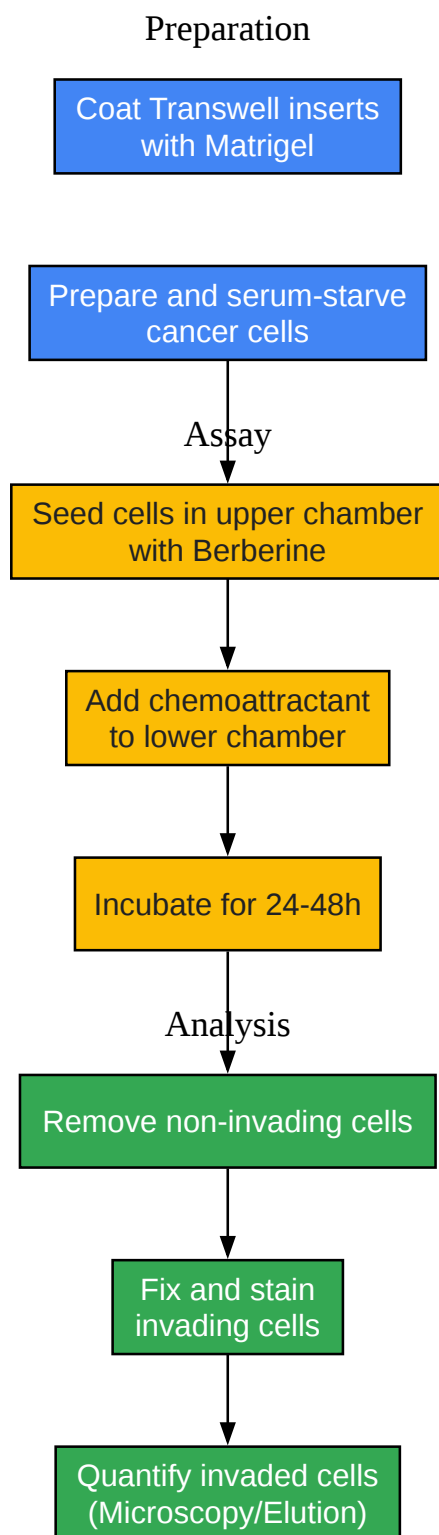

[Click to download full resolution via product page](#)

Workflow for the Transwell Invasion Assay with Berberine.

**Need Custom Synthesis?**

BenchChem offers custom synthesis for rare earth carbides and specific isotopic labeling.

Email: [info@benchchem.com](mailto:info@benchchem.com) or [Request Quote Online](#).

## References

- 1. mdpi.com [mdpi.com]
- 2. Frontiers | Effects of Berberine and Its Derivatives on Cancer: A Systems Pharmacology Review [frontiersin.org]
- 3. The Anti-Cancer Mechanisms of Berberine: A Review - PMC [pmc.ncbi.nlm.nih.gov]
- 4. mdpi.com [mdpi.com]
- 5. researchgate.net [researchgate.net]
- 6. Berberine Suppresses EMT in Liver and Gastric Carcinoma Cells through Combination with TGF $\beta$ R Regulating TGF- $\beta$ /Smad Pathway - PMC [pmc.ncbi.nlm.nih.gov]
- 7. researchgate.net [researchgate.net]
- 8. Berberine: An Important Emphasis on Its Anticancer Effects through Modulation of Various Cell Signaling Pathways - PMC [pmc.ncbi.nlm.nih.gov]
- 9. Regulation of Cell Signaling Pathways by Berberine in Different Cancers: Searching for Missing Pieces of an Incomplete Jig-Saw Puzzle for an Effective Cancer Therapy - PMC [pmc.ncbi.nlm.nih.gov]
- 10. tandfonline.com [tandfonline.com]
- 11. researchgate.net [researchgate.net]
- 12. Berberine inhibits the migration and invasion of T24 bladder cancer cells via reducing the expression of heparanase - PubMed [pubmed.ncbi.nlm.nih.gov]
- 13. Berberine Inhibits Invasion and Metastasis of Colorectal Cancer Cells via COX-2/PGE2 Mediated JAK2/STAT3 Signaling Pathway - PMC [pmc.ncbi.nlm.nih.gov]
- 14. researchgate.net [researchgate.net]
- 15. Epithelial-to-mesenchymal transition markers to predict response of Berberine in suppressing lung cancer invasion and metastasis - PMC [pmc.ncbi.nlm.nih.gov]
- To cite this document: BenchChem. [Application Notes and Protocols: Transwell Invasion Assay with Berberine Treatment]. BenchChem, [2025]. [Online PDF]. Available at:

[<https://www.benchchem.com/product/b1197929#transwell-invasion-assay-with-wilfordine-treatment>]

---

**Disclaimer & Data Validity:**

The information provided in this document is for Research Use Only (RUO) and is strictly not intended for diagnostic or therapeutic procedures. While BenchChem strives to provide accurate protocols, we make no warranties, express or implied, regarding the fitness of this product for every specific experimental setup.

**Technical Support:** The protocols provided are for reference purposes. Unsure if this reagent suits your experiment? [[Contact our Ph.D. Support Team for a compatibility check](#)]

**Need Industrial/Bulk Grade?** [Request Custom Synthesis Quote](#)

## BenchChem

Our mission is to be the trusted global source of essential and advanced chemicals, empowering scientists and researchers to drive progress in science and industry.

### Contact

Address: 3281 E Guasti Rd  
Ontario, CA 91761, United States  
Phone: (601) 213-4426  
Email: [info@benchchem.com](mailto:info@benchchem.com)