

# Application Notes and Protocols: Thallium(III) Chloride Catalyzed Aromatic Acylation

**Author:** BenchChem Technical Support Team. **Date:** December 2025

## Compound of Interest

Compound Name: *Thallium(III) chloride tetrahydrate*

Cat. No.: *B12060300*

[Get Quote](#)

For Researchers, Scientists, and Drug Development Professionals

These application notes provide a comprehensive overview of the mechanism and application of Thallium(III) chloride ( $TlCl_3$ ) as a catalyst in aromatic acylation, a key reaction in the synthesis of aromatic ketones. The protocols detailed below are based on established research and are intended to serve as a guide for laboratory implementation.

## Introduction

Aromatic acylation, a cornerstone of Friedel-Crafts chemistry, is an essential method for the formation of carbon-carbon bonds and the synthesis of aryl ketones, which are pivotal intermediates in the pharmaceutical and fine chemical industries. While aluminum chloride ( $AlCl_3$ ) is the conventional catalyst for this transformation, its high reactivity can lead to undesired side reactions and harsh reaction conditions. Thallium(III) chloride has emerged as a milder Lewis acid catalyst, offering an alternative with potentially different selectivities and milder reaction parameters.

## Mechanism of Catalysis

The catalytic cycle of Thallium(III) chloride in aromatic acylation is analogous to the general mechanism of Friedel-Crafts acylation.  $TlCl_3$  functions as a Lewis acid, activating the acylating agent to generate a highly electrophilic acylium ion.

Key Mechanistic Steps:

- **Formation of the Acylium Ion:** Thallium(III) chloride coordinates with the acyl halide (or anhydride), polarizing the carbon-halogen bond and facilitating its cleavage to form a resonance-stabilized acylium ion ( $R-C\equiv O^+$ ) and the tetrachlorothallate(III) anion ( $[TlCl_4]^-$ ).
- **Electrophilic Aromatic Substitution:** The electron-rich aromatic ring attacks the electrophilic carbon of the acylium ion, forming a sigma complex (also known as an arenium ion). This step is typically the rate-determining step of the reaction.
- **Deprotonation and Catalyst Regeneration:** A weak base, often the  $[TlCl_4]^-$  anion, abstracts a proton from the sigma complex, restoring the aromaticity of the ring and yielding the final aryl ketone product. This step also regenerates the Thallium(III) chloride catalyst, allowing it to participate in subsequent catalytic cycles.

Research indicates that Thallium(III) chloride is a milder Lewis acid compared to aluminum chloride and ferric chloride, with its catalytic activity being more comparable to that of zinc chloride.<sup>[1][2][3][4][5]</sup> Notably, the hydrated form of the catalyst, **Thallium(III) chloride tetrahydrate** ( $TlCl_3 \cdot 4H_2O$ ), has been reported to be more effective in some cases, suggesting that water may play a role in the catalytic cycle, possibly by influencing the catalyst's solubility or Lewis acidity.<sup>[1][2][3][4][5]</sup>

## Visualizing the Catalytic Cycle

The following diagram illustrates the proposed mechanism for Thallium(III) chloride catalyzed aromatic acylation.

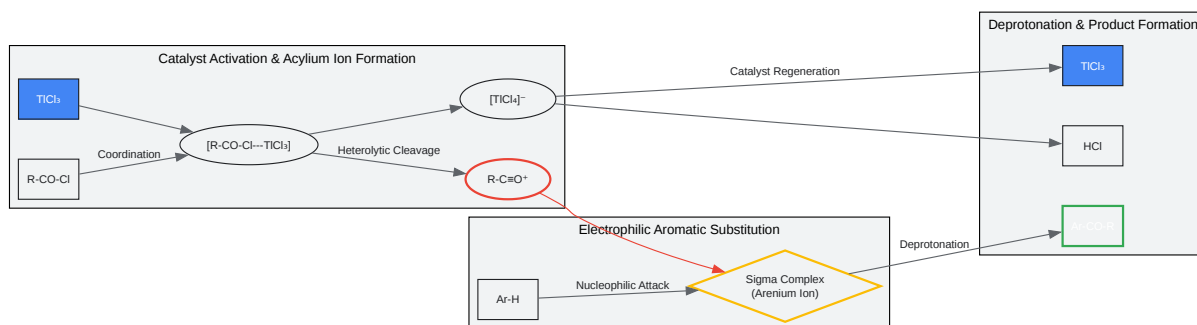

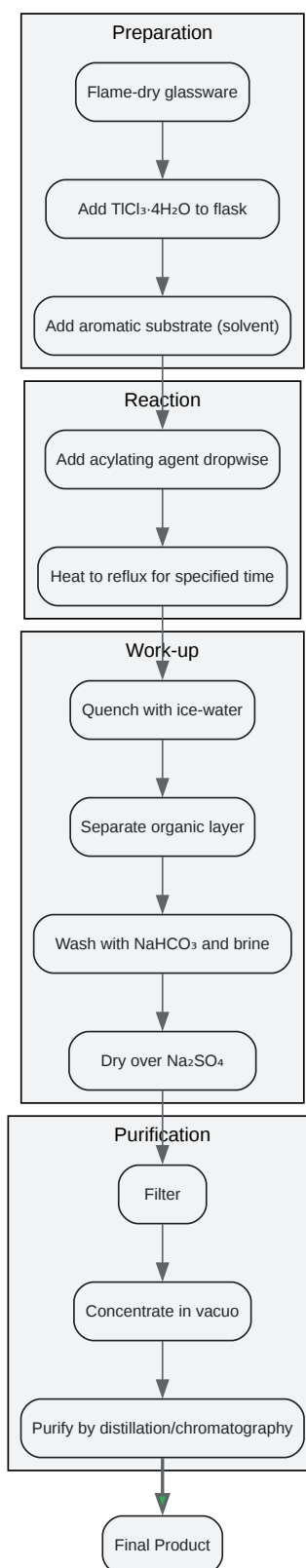

[Click to download full resolution via product page](#)

### Need Custom Synthesis?

BenchChem offers custom synthesis for rare earth carbides and specific isotopic labeling.

Email: [info@benchchem.com](mailto:info@benchchem.com) or [Request Quote Online](#).

## References

- 1. [pubs.acs.org](https://pubs.acs.org) [[pubs.acs.org](https://pubs.acs.org)]
- 2. [researchgate.net](https://researchgate.net) [[researchgate.net](https://researchgate.net)]
- 3. [researchgate.net](https://researchgate.net) [[researchgate.net](https://researchgate.net)]
- 4. [researchgate.net](https://researchgate.net) [[researchgate.net](https://researchgate.net)]
- 5. [researchgate.net](https://researchgate.net) [[researchgate.net](https://researchgate.net)]
- To cite this document: BenchChem. [Application Notes and Protocols: Thallium(III) Chloride Catalyzed Aromatic Acylation]. BenchChem, [2025]. [Online PDF]. Available at: [<https://www.benchchem.com/product/b12060300#mechanism-of-thallium-iii-chloride-catalyzed-aromatic-acylation>]

---

### Disclaimer & Data Validity:

The information provided in this document is for Research Use Only (RUO) and is strictly not intended for diagnostic or therapeutic procedures. While BenchChem strives to provide accurate protocols, we make no warranties, express or implied, regarding the fitness of this product for every specific experimental setup.

**Technical Support:** The protocols provided are for reference purposes. Unsure if this reagent suits your experiment? [[Contact our Ph.D. Support Team for a compatibility check](#)]

**Need Industrial/Bulk Grade?** [Request Custom Synthesis Quote](#)

# BenchChem

Our mission is to be the trusted global source of essential and advanced chemicals, empowering scientists and researchers to drive progress in science and industry.

## Contact

Address: 3281 E Guasti Rd  
Ontario, CA 91761, United States  
Phone: (601) 213-4426  
Email: [info@benchchem.com](mailto:info@benchchem.com)