

Application Notes and Protocols: Testing Synergistic Effects of Halomicin B with Other Drugs

Author: BenchChem Technical Support Team. **Date:** December 2025

Compound of Interest

Compound Name: *Halomicin B*

Cat. No.: *B1236205*

[Get Quote](#)

For Researchers, Scientists, and Drug Development Professionals

Introduction

Halomicin B is an ansamycin antibiotic with documented activity against both Gram-positive and Gram-negative bacteria[1]. As the challenge of antimicrobial resistance grows, combination therapies that exhibit synergistic effects are of increasing interest. Synergism occurs when the combined effect of two or more drugs is greater than the sum of their individual effects, potentially leading to lower required doses, reduced toxicity, and a decreased likelihood of resistance development[2][3][4].

These application notes provide a comprehensive protocol for evaluating the synergistic potential of **Halomicin B** when used in combination with other antimicrobial agents. The primary methodologies detailed are the checkerboard microdilution assay and the subsequent analysis of the interaction through the calculation of the Fractional Inhibitory Concentration Index (FICI) and isobologram analysis.

Rationale for Synergy Testing

Combining antimicrobial agents can result in one of three outcomes:

- Synergy: The combined effect is significantly greater than the sum of the individual effects[2][3].

- Additivity (or Indifference): The combined effect is equal to the sum of the individual effects[5].
- Antagonism: The combined effect is less than the sum of the individual effects[2][3].

The primary goal of synergy testing is to identify drug combinations that are more potent than the individual drugs alone, a crucial strategy in combating multi-drug resistant (MDR) pathogens[6][7][8].

Key Methodologies for Synergy Testing

Checkerboard Microdilution Assay

The checkerboard assay is a widely used in vitro method to assess the synergistic, additive, or antagonistic effects of antimicrobial combinations[9][10][11]. This technique involves a two-dimensional array of serial dilutions of two drugs, tested against a standardized bacterial inoculum.

Data Analysis and Interpretation

The interaction between **Halomicin B** and a second drug is quantified by calculating the Fractional Inhibitory Concentration (FIC) Index. The FIC is calculated for each drug in the combination that results in the inhibition of bacterial growth (the Minimum Inhibitory Concentration, or MIC, of the combination).

The FIC Index is the sum of the individual FICs:

$$\text{FIC Index} = \text{FIC of Drug A} + \text{FIC of Drug B}$$

Where:

- FIC of Drug A = (MIC of Drug A in combination) / (MIC of Drug A alone)
- FIC of Drug B = (MIC of Drug B in combination) / (MIC of Drug B alone)

The interpretation of the FIC Index is summarized in the table below.

FIC Index	Interpretation
≤ 0.5	Synergy
> 0.5 to ≤ 1.0	Additivity
> 1.0 to < 4.0	Indifference
≥ 4.0	Antagonism

Source:[12][13][14]

Experimental Protocols

Materials

- **Halomicin B**
- Second antimicrobial agent(s) for testing
- 96-well microtiter plates
- Bacterial strain(s) of interest
- Appropriate broth medium (e.g., Mueller-Hinton Broth)
- Sterile multichannel pipettes and reservoirs
- Incubator
- Microplate reader (optional, for quantitative growth assessment)

Preparation of Reagents

- **Bacterial Inoculum:** Prepare a bacterial suspension equivalent to a 0.5 McFarland standard. This should then be diluted to achieve a final concentration of approximately 5×10^5 CFU/mL in the test wells[12].
- **Drug Stock Solutions:** Prepare stock solutions of **Halomicin B** and the second drug at a concentration that is a multiple of the highest concentration to be tested (e.g., 4x the highest

desired concentration) in the appropriate broth medium[10].

Checkerboard Assay Protocol

- Plate Setup: Add a sterile liquid medium to all wells of a 96-well plate.
- Drug A (**Halomicin B**) Dilution: Serially dilute **Halomicin B** horizontally across the plate.
- Drug B Dilution: Serially dilute the second drug vertically down the plate.
- Inoculation: Inoculate each well with the prepared bacterial suspension.
- Controls: Include wells with bacteria and no drugs (positive growth control) and wells with medium only (negative control). Also, include rows and columns with each drug individually to determine their standalone MICs.
- Incubation: Incubate the plates under appropriate conditions (e.g., 35-37°C for 18-24 hours).
- Reading Results: Determine the MIC for each drug alone and in combination by visually inspecting for turbidity or by using a microplate reader. The MIC is the lowest concentration of the drug(s) that inhibits visible bacterial growth.

Data Presentation and Visualization

Tabular Representation of Results

The results of the checkerboard assay should be recorded in a table, with the concentrations of **Halomicin B** along one axis and the concentrations of the second drug along the other. The wells showing inhibition of bacterial growth should be clearly marked.

Example Data Table:

Halomicin B (µg/mL)	Drug B - 16 µg/mL	Drug B - 8 µg/mL	Drug B - 4 µg/mL	Drug B - 2 µg/mL	Drug B - 1 µg/mL	Drug B - 0.5 µg/mL	Drug B - 0 µg/mL (MIC of Halomicin B alone)
8	-	-	-	-	-	-	-
4	-	-	-	-	-	+	+
2	-	-	-	+	+	+	+
1	-	-	+	+	+	+	+
0.5	-	+	+	+	+	+	+
0.25	+	+	+	+	+	+	+
0 (MIC of Drug B alone)	-	-	-	+	+	+	N/A

(+) indicates growth, (-) indicates no growth.

From this table, the MIC of each drug alone and in combination can be determined, and the FIC Index can be calculated.

Isobologram Analysis

An isobologram is a graphical representation of drug interactions[2][3][15][16]. It plots the concentrations of two drugs that produce a specific effect (e.g., inhibition of bacterial growth).

- The x-axis represents the concentration of **Halomicin B**.
- The y-axis represents the concentration of the second drug.
- A straight line connecting the MICs of the individual drugs represents additivity.
- Data points falling below this line indicate synergy.

- Data points falling above this line indicate antagonism.

Visualizations

Experimental Workflow

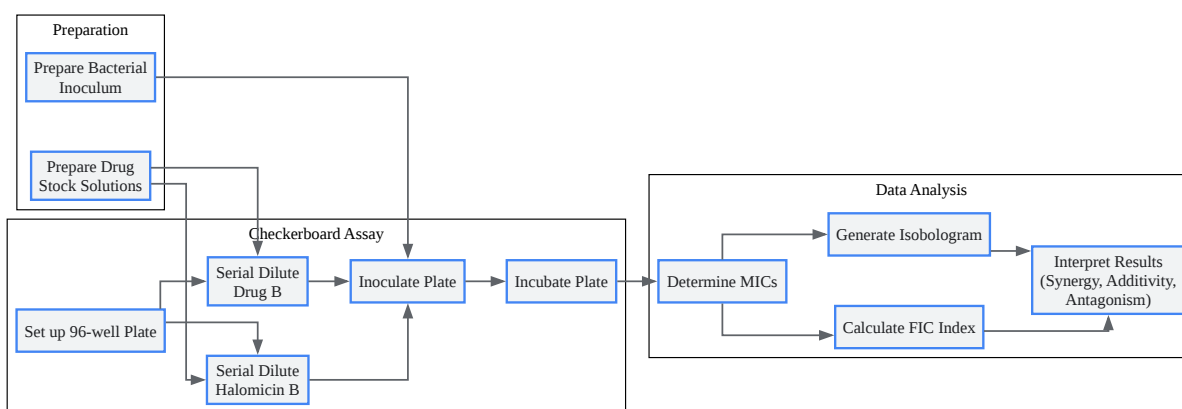

[Click to download full resolution via product page](#)

Caption: Workflow for assessing drug synergy using the checkerboard assay.

Conceptual Diagram of Drug Synergy

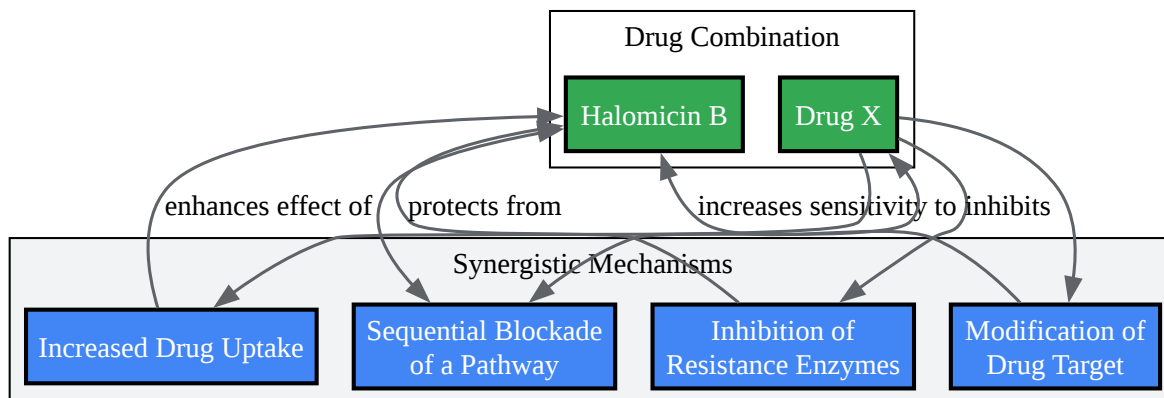

[Click to download full resolution via product page](#)

Caption: Potential mechanisms of synergistic action between two antimicrobial drugs.

Need Custom Synthesis?

BenchChem offers custom synthesis for rare earth carbides and specific isotopic labeling.

Email: info@benchchem.com or [Request Quote Online](#).

References

- 1. medchemexpress.com [medchemexpress.com]
- 2. Frontiers | Isobologram Analysis: A Comprehensive Review of Methodology and Current Research [frontiersin.org]
- 3. Isobologram Analysis: A Comprehensive Review of Methodology and Current Research - PMC [pmc.ncbi.nlm.nih.gov]
- 4. researchgate.net [researchgate.net]
- 5. punnettsquare.org [punnettsquare.org]
- 6. Species-specific activity of antibacterial drug combinations - PMC [pmc.ncbi.nlm.nih.gov]
- 7. Surprising synergy of dual translation inhibition vs. *Acinetobacter baumannii* and other multidrug-resistant bacterial pathogens - PMC [pmc.ncbi.nlm.nih.gov]

- 8. cdn.fraserlab.com [cdn.fraserlab.com]
- 9. Miniaturized Checkerboard Assays to Measure Antibiotic Interactions | Springer Nature Experiments [experiments.springernature.com]
- 10. New and simplified method for drug combination studies by checkerboard assay - PMC [pmc.ncbi.nlm.nih.gov]
- 11. When Does 2 Plus 2 Equal 5? A Review of Antimicrobial Synergy Testing - PMC [pmc.ncbi.nlm.nih.gov]
- 12. Antimicrobial Synergy Testing/Checkerboard Assay - Creative Diagnostics [antiviral.creative-diagnostics.com]
- 13. journals.asm.org [journals.asm.org]
- 14. Synergistic effect of clinically used antibiotics and peptide antibiotics against Gram-positive and Gram-negative bacteria - PMC [pmc.ncbi.nlm.nih.gov]
- 15. An overview of drug combination analysis with isobolograms - PubMed [pubmed.ncbi.nlm.nih.gov]
- 16. SynergyFinder™ Drug Combination Studies | Oncolines B.V. [oncolines.com]
- To cite this document: BenchChem. [Application Notes and Protocols: Testing Synergistic Effects of Halomicin B with Other Drugs]. BenchChem, [2025]. [Online PDF]. Available at: [<https://www.benchchem.com/product/b1236205#protocol-for-testing-synergistic-effects-of-halomicin-b-with-other-drugs>]

Disclaimer & Data Validity:

The information provided in this document is for Research Use Only (RUO) and is strictly not intended for diagnostic or therapeutic procedures. While BenchChem strives to provide accurate protocols, we make no warranties, express or implied, regarding the fitness of this product for every specific experimental setup.

Technical Support: The protocols provided are for reference purposes. Unsure if this reagent suits your experiment? [[Contact our Ph.D. Support Team for a compatibility check](#)]

Need Industrial/Bulk Grade? [Request Custom Synthesis Quote](#)

BenchChem

Our mission is to be the trusted global source of essential and advanced chemicals, empowering scientists and researchers to drive progress in science and industry.

Contact

Address: 3281 E Guasti Rd

Ontario, CA 91761, United States

Phone: (601) 213-4426

Email: info@benchchem.com