

Application Notes and Protocols: Synthesis of Brefonalol

Author: BenchChem Technical Support Team. **Date:** December 2025

Compound of Interest

Compound Name: *Brefonalol*

Cat. No.: *B1667777*

[Get Quote](#)

For Researchers, Scientists, and Drug Development Professionals

Abstract

Brefonalol is a beta-adrenergic antagonist with vasodilating properties, positioning it as a compound of interest for cardiovascular research.[1][2][3] These application notes provide a detailed, plausible synthetic pathway for **Brefonalol**, based on established methodologies for the synthesis of analogous aryloxypropanolamine beta-blockers.[4][5] The protocols herein offer a comprehensive guide for the laboratory-scale synthesis, purification, and characterization of **Brefonalol**.

Introduction

Brefonalol, with the IUPAC name 6-[1-Hydroxy-2-[(2-methyl-4-phenylbutan-2-yl)amino]ethyl]-3,4-dihydro-1H-quinolin-2-one, is a beta-blocker that has been studied for its potential in treating hypertension.[1][3][6] Like many beta-blockers, its structure features an aryloxypropanolamine moiety, which is crucial for its pharmacological activity.[5][7] This document outlines a retro-synthetic analysis and a forward synthetic protocol for **Brefonalol**, providing researchers with a practical guide for its preparation.

Retrosynthetic Analysis

The synthesis of **Brefonalol** can be approached through a convergent strategy, starting from commercially available precursors. The key disconnection lies at the ether and amine bonds of

the propanolamine side chain. This leads to three primary starting materials: a substituted quinolinone, epichlorohydrin, and a specific substituted amine.

Synthesis Pathway

A proposed synthetic pathway for **Brefonalol** is a two-step process common for this class of compounds. The first step involves the formation of an epoxide intermediate via the reaction of 6-hydroxy-3,4-dihydro-1H-quinolin-2-one with epichlorohydrin. The second step is the nucleophilic opening of the epoxide ring by 2-methyl-4-phenylbutan-2-amine to yield the final product, **Brefonalol**.

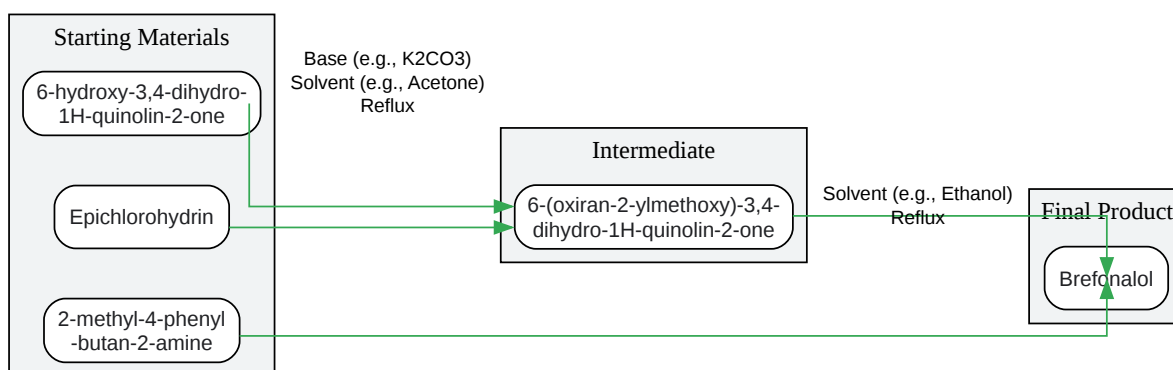

[Click to download full resolution via product page](#)

Caption: Proposed two-step synthesis pathway for **Brefonalol**.

Experimental Protocols

Step 1: Synthesis of 6-(oxiran-2-ylmethoxy)-3,4-dihydro-1H-quinolin-2-one (Intermediate 1)

Materials:

- 6-hydroxy-3,4-dihydro-1H-quinolin-2-one

- Epichlorohydrin
- Potassium carbonate (K₂CO₃), anhydrous
- Acetone, anhydrous

Procedure:

- To a stirred solution of 6-hydroxy-3,4-dihydro-1H-quinolin-2-one in anhydrous acetone, add anhydrous potassium carbonate.
- Add epichlorohydrin dropwise to the suspension at room temperature.
- Heat the reaction mixture to reflux and maintain for 12-18 hours. Monitor the reaction progress by Thin Layer Chromatography (TLC).
- After completion, cool the mixture to room temperature and filter to remove the inorganic salts.
- Evaporate the solvent from the filtrate under reduced pressure to obtain the crude product.
- Purify the crude product by column chromatography on silica gel using a suitable eluent system (e.g., ethyl acetate/hexane gradient) to yield the pure epoxide intermediate.

Step 2: Synthesis of Brefonalol

Materials:

- 6-(oxiran-2-ylmethoxy)-3,4-dihydro-1H-quinolin-2-one (Intermediate 1)
- 2-methyl-4-phenylbutan-2-amine
- Ethanol

Procedure:

- Dissolve the epoxide intermediate in ethanol.
- Add 2-methyl-4-phenylbutan-2-amine to the solution.

- Heat the reaction mixture to reflux and maintain for 6-10 hours. Monitor the reaction progress by TLC.
- Upon completion, cool the reaction mixture and evaporate the solvent under reduced pressure.
- The crude product can be purified by recrystallization from a suitable solvent (e.g., ethanol/water mixture) or by column chromatography to yield pure **Brefonalol**.

Quantitative Data Summary

The following table summarizes the expected quantitative data for the synthesis of **Brefonalol**, based on typical yields for analogous reactions in the synthesis of other beta-blockers.

Step	Reactants	Product	Molar Ratio	Solvent	Temperature (°C)	Time (h)	Yield (%)
1	6-hydroxy-3,4-dihydro-1H-quinolin-2-one, Epichlorohydrin, K ₂ CO ₃	6-(oxiran-2-ylmethoxy)-3,4-dihydro-1H-quinolin-2-one	1 : 1.2 : 2	Acetone	56 (Reflux)	12-18	85-95
2	6-(oxiran-2-ylmethoxy)-3,4-dihydro-1H-quinolin-2-one, 2-methyl-4-phenylbutan-2-amine	Brefonalol	1 : 1.1	Ethanol	78 (Reflux)	6-10	70-85

Experimental Workflow

The overall experimental workflow for the synthesis and purification of **Brefonalol** is depicted below.

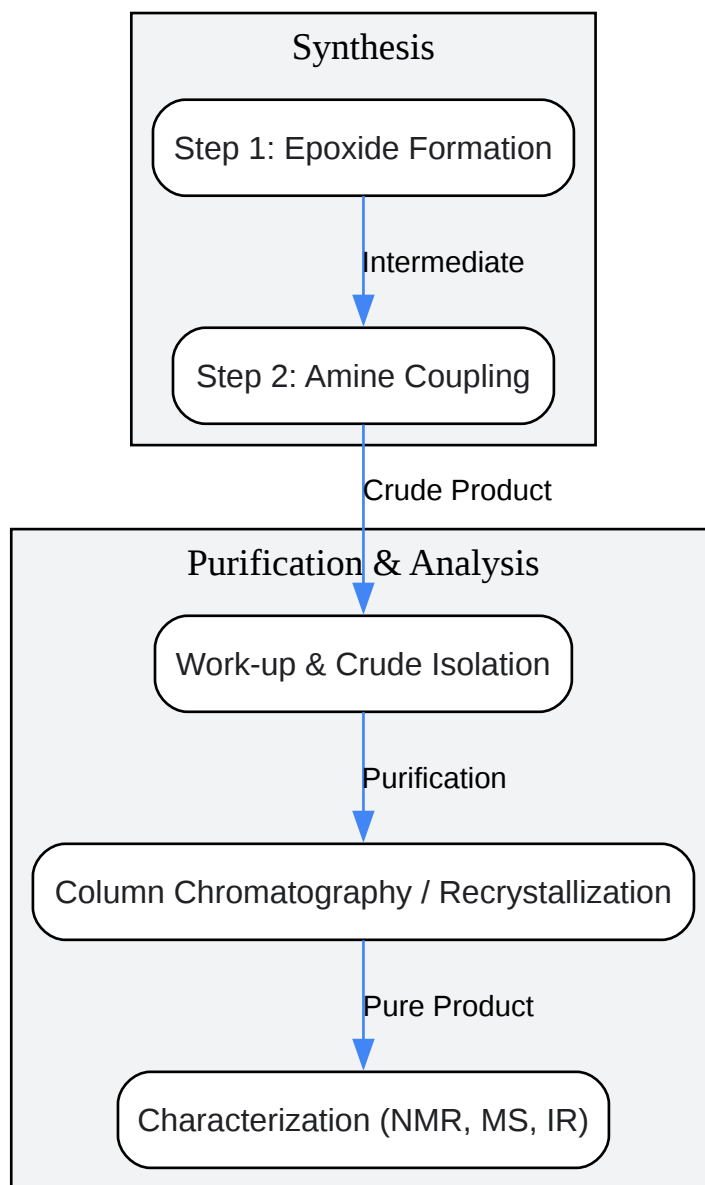

[Click to download full resolution via product page](#)

Caption: General experimental workflow for **Brefonalol** synthesis.

Characterization

The final product, **Brefonalol**, should be characterized using standard analytical techniques to confirm its identity and purity.

- ^1H NMR and ^{13}C NMR: To confirm the chemical structure and the presence of all expected functional groups.

- Mass Spectrometry (MS): To determine the molecular weight of the synthesized compound.
- Infrared (IR) Spectroscopy: To identify the key functional groups (e.g., -OH, -NH, C=O).
- High-Performance Liquid Chromatography (HPLC): To assess the purity of the final compound.

Safety Precautions

- All experimental procedures should be carried out in a well-ventilated fume hood.
- Personal protective equipment (PPE), including safety glasses, lab coat, and gloves, should be worn at all times.
- Epichlorohydrin is a carcinogen and should be handled with extreme care.
- Consult the Safety Data Sheets (SDS) for all chemicals used in the synthesis.

These protocols provide a robust framework for the synthesis of **Brefonalol**, enabling further research into its pharmacological properties and potential therapeutic applications.

Need Custom Synthesis?

BenchChem offers custom synthesis for rare earth carbides and specific isotopic labeling.

Email: info@benchchem.com or [Request Quote Online](#).

References

1. Brefonalol - Wikipedia [en.wikipedia.org]
2. medchemexpress.com [medchemexpress.com]
3. Hemodynamic effects of brefanolol and propranolol assessed by noninvasive methods in patients with arterial hypertension - PubMed [pubmed.ncbi.nlm.nih.gov]
4. Synthesis and pharmacology of potential beta-blockers - PubMed [pubmed.ncbi.nlm.nih.gov]
5. Brefonalol | 104051-20-9 | Benchchem [benchchem.com]

- 6. Brefonalol | C₂₂H₂₈N₂O₂ | CID 65880 - PubChem [pubchem.ncbi.nlm.nih.gov]
- 7. SAR and Synthesis of adrenergic blockers | PPTX [slideshare.net]
- To cite this document: BenchChem. [Application Notes and Protocols: Synthesis of Brefonalol]. BenchChem, [2025]. [Online PDF]. Available at: [https://www.benchchem.com/product/b1667777#brefonalol-synthesis-pathway-and-methodology]

Disclaimer & Data Validity:

The information provided in this document is for Research Use Only (RUO) and is strictly not intended for diagnostic or therapeutic procedures. While BenchChem strives to provide accurate protocols, we make no warranties, express or implied, regarding the fitness of this product for every specific experimental setup.

Technical Support: The protocols provided are for reference purposes. Unsure if this reagent suits your experiment? [[Contact our Ph.D. Support Team for a compatibility check](#)]

Need Industrial/Bulk Grade? [Request Custom Synthesis Quote](#)

BenchChem

Our mission is to be the trusted global source of essential and advanced chemicals, empowering scientists and researchers to drive progress in science and industry.

Contact

Address: 3281 E Guasti Rd
Ontario, CA 91761, United States
Phone: (601) 213-4426
Email: info@benchchem.com