

Application Notes and Protocols: Synthesis and Purification of Antiproliferative Agent-25

Author: BenchChem Technical Support Team. **Date:** December 2025

Compound of Interest

Compound Name: *Antiproliferative agent-25*

Cat. No.: *B12380952*

[Get Quote](#)

These application notes provide a detailed overview of the synthesis and purification techniques for **Antiproliferative Agent-25**, a novel quinoxaline derivative with demonstrated antiproliferative properties. The protocols outlined below are intended for researchers and scientists in the field of drug development and medicinal chemistry.

Overview of Antiproliferative Agent-25

Antiproliferative Agent-25 belongs to a class of quinoxaline derivatives that have shown significant potential in cancer research. These compounds exert their effects through various mechanisms, including the inhibition of topoisomerase II β , a critical enzyme in cell division. The specific compound detailed in these notes, a non-aromatic substituted epoxide derivative of quinoxaline, has exhibited notable bioavailability in in silico studies.[1]

Synthesis of Antiproliferative Agent-25

The synthesis of **Antiproliferative Agent-25** is achieved through a multi-step process involving the formation of a quinoxaline core, followed by the addition of an arylethynyl moiety and subsequent epoxidation. The general synthetic scheme is depicted below.

Diagram of Synthesis Workflow

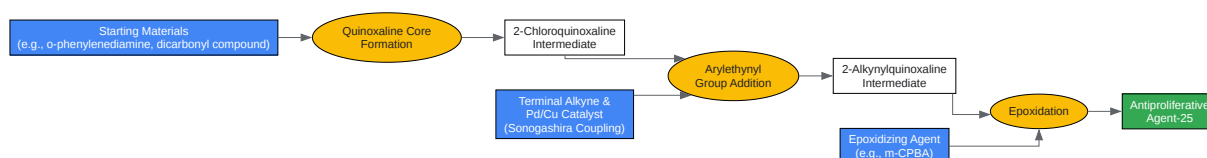

[Click to download full resolution via product page](#)

Caption: A generalized workflow for the synthesis of **Antiproliferative Agent-25**.

Experimental Protocol: Synthesis of a Quinoxaline Derivative (Illustrative Example)

This protocol is a representative example for the synthesis of a quinoxaline derivative, based on general methodologies.

Step 1: Quinoxaline Core Synthesis

- Dissolve o-phenylenediamine in a suitable solvent such as ethanol.
- Add an equimolar amount of a dicarbonyl compound (e.g., glyoxal) dropwise at room temperature.
- Reflux the reaction mixture for 2-4 hours.
- Monitor the reaction progress by Thin Layer Chromatography (TLC).
- Upon completion, cool the mixture and remove the solvent under reduced pressure.
- Purify the crude product by recrystallization from ethanol to obtain the quinoxaline core.

Step 2: Chlorination

- Treat the quinoxaline core with a chlorinating agent (e.g., POCl₃) at elevated temperature.

- After the reaction is complete, carefully quench the reaction mixture with ice-water.
- Extract the product with an organic solvent (e.g., dichloromethane).
- Dry the organic layer over anhydrous sodium sulfate and concentrate to yield the 2-chloroquinoxaline intermediate.

Step 3: Sonogashira Coupling

- To a solution of the 2-chloroquinoxaline intermediate in a solvent system like triethylamine and THF, add a terminal alkyne.
- Add catalytic amounts of a palladium catalyst (e.g., Pd(PPh₃)₂Cl₂) and a copper(I) co-catalyst (e.g., CuI).
- Stir the reaction mixture at room temperature under an inert atmosphere (e.g., nitrogen or argon) until the starting material is consumed.
- Filter the reaction mixture to remove the catalyst and concentrate the filtrate.
- Purify the residue by column chromatography.

Step 4: Epoxidation

- Dissolve the 2-alkynylquinoxaline intermediate in a chlorinated solvent (e.g., dichloromethane).
- Add an epoxidizing agent, such as meta-chloroperoxybenzoic acid (m-CPBA), portion-wise at 0 °C.
- Allow the reaction to warm to room temperature and stir for 12-24 hours.
- Wash the reaction mixture with a saturated sodium bicarbonate solution to remove excess acid.
- Extract the aqueous layer with dichloromethane.

- Combine the organic layers, dry over anhydrous sodium sulfate, and concentrate to yield the crude final product, **Antiproliferative Agent-25**.

Purification of Antiproliferative Agent-25

Purification of the synthesized agent is crucial to remove impurities, byproducts, and unreacted reagents. A combination of chromatographic and crystallization techniques is typically employed.

Diagram of Purification Workflow

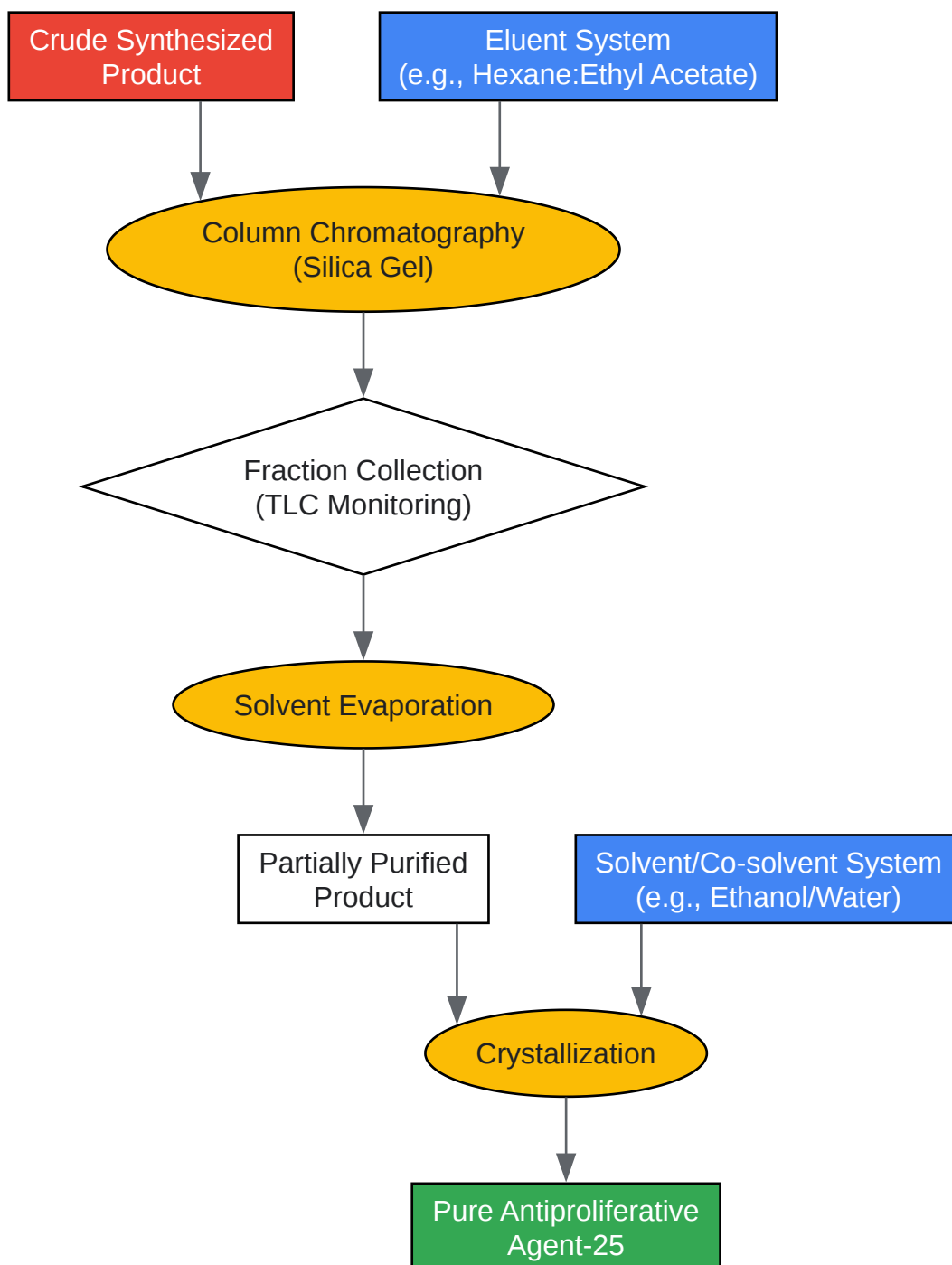

[Click to download full resolution via product page](#)

Caption: A standard workflow for the purification of **Antiproliferative Agent-25**.

Experimental Protocol: Purification

1. Flash Column Chromatography

- Prepare a silica gel slurry in the chosen eluent system (e.g., a gradient of hexane and ethyl acetate).
- Pack a glass column with the slurry.
- Dissolve the crude product in a minimal amount of the eluent or a suitable solvent and load it onto the column.
- Elute the column with the solvent system, gradually increasing the polarity.
- Collect fractions and monitor them by TLC to identify those containing the pure product.
- Combine the pure fractions and evaporate the solvent under reduced pressure.

2. Crystallization

- Dissolve the partially purified product from chromatography in a minimum amount of a hot solvent (e.g., ethanol).
- If necessary, add a co-solvent (e.g., water) dropwise until turbidity persists.
- Allow the solution to cool slowly to room temperature, then place it in a refrigerator or ice bath to facilitate crystal formation.
- Collect the crystals by vacuum filtration.
- Wash the crystals with a small amount of cold solvent.
- Dry the purified crystals under vacuum.

Quantitative Data Summary

The following table summarizes typical quantitative data for the synthesis and activity of quinoxaline derivatives similar to **Antiproliferative Agent-25**.

Parameter	Value	Reference
Synthesis Yield (trans isomer)	32% - 49%	[1]
Synthesis Yield (cis isomer)	48%	[1]
Purity (Post-Purification)	>95%	General laboratory standard
Bioavailability (F value, in silico)	89.24%	[1]
IC ₅₀ (SK-N-SH cell line, related compounds)	2.49 ± 1.33 μM - 5.3 ± 2.12 μM	[1]
IC ₅₀ (IMR-32 cell line, related compounds)	3.96 ± 2.03 μM - 7.12 ± 1.59 μM	[1]

Postulated Signaling Pathway

Many antiproliferative agents function by inhibiting key signaling pathways involved in cell growth and proliferation. While the specific pathway for **Antiproliferative Agent-25** is under investigation, a common target for such compounds is the receptor tyrosine kinase (RTK) pathway.

Diagram of a Representative Signaling Pathway

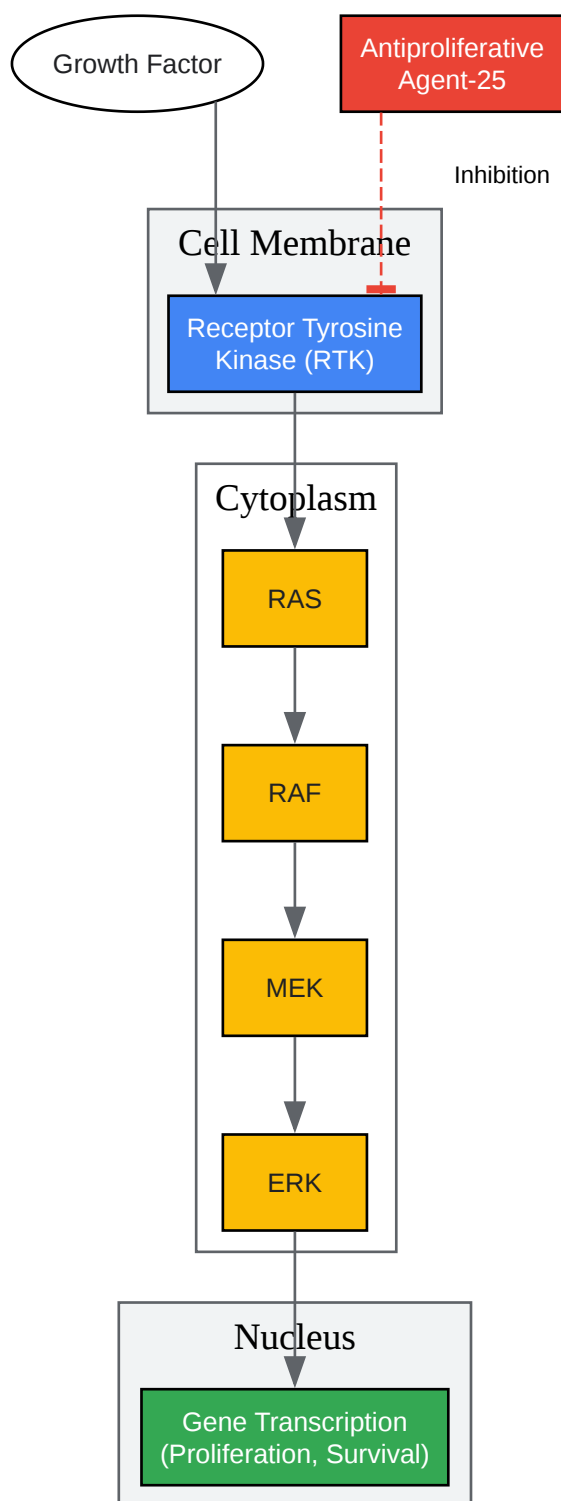

[Click to download full resolution via product page](#)

Caption: A representative RTK signaling pathway potentially inhibited by antiproliferative agents.

Need Custom Synthesis?

BenchChem offers custom synthesis for rare earth carbides and specific isotopic labeling.

Email: info@benchchem.com or [Request Quote Online](#).

References

- 1. [mdpi.com](https://www.mdpi.com) [[mdpi.com](https://www.mdpi.com)]
- To cite this document: BenchChem. [Application Notes and Protocols: Synthesis and Purification of Antiproliferative Agent-25]. BenchChem, [2025]. [Online PDF]. Available at: [<https://www.benchchem.com/product/b12380952#antiproliferative-agent-25-synthesis-and-purification-techniques>]

Disclaimer & Data Validity:

The information provided in this document is for Research Use Only (RUO) and is strictly not intended for diagnostic or therapeutic procedures. While BenchChem strives to provide accurate protocols, we make no warranties, express or implied, regarding the fitness of this product for every specific experimental setup.

Technical Support: The protocols provided are for reference purposes. Unsure if this reagent suits your experiment? [[Contact our Ph.D. Support Team for a compatibility check](#)]

Need Industrial/Bulk Grade? [Request Custom Synthesis Quote](#)

BenchChem

Our mission is to be the trusted global source of essential and advanced chemicals, empowering scientists and researchers to drive progress in science and industry.

Contact

Address: 3281 E Guasti Rd

Ontario, CA 91761, United States

Phone: (601) 213-4426

Email: info@benchchem.com