

Application Notes and Protocols: (S)-1-Boc-3-aminopiperidine in Medicinal Chemistry

Author: BenchChem Technical Support Team. **Date:** December 2025

Compound of Interest

Compound Name: (S)-1-Boc-3-aminopiperidine

Cat. No.: B046749

[Get Quote](#)

(S)-1-Boc-3-aminopiperidine is a versatile, chiral building block of significant interest to researchers, scientists, and drug development professionals. Its unique structural features, including a protected amine and a chiral center within a piperidine scaffold, make it an invaluable component in the synthesis of complex molecular architectures for novel therapeutics. This document provides detailed application notes and experimental protocols for its use in medicinal chemistry, with a focus on the development of kinase inhibitors.

Application Notes

(S)-1-Boc-3-aminopiperidine serves as a crucial intermediate in the synthesis of a variety of bioactive molecules. The tert-butoxycarbonyl (Boc) protecting group offers stability and allows for selective deprotection under acidic conditions, facilitating subsequent synthetic transformations. The chiral amine at the 3-position of the piperidine ring is a key pharmacophoric element in many drug candidates, enabling specific interactions with biological targets.

Key applications of **(S)-1-Boc-3-aminopiperidine** in medicinal chemistry include:

- **Synthesis of Kinase Inhibitors:** This building block is prominently used in the development of inhibitors for various kinases, which are critical targets in oncology and immunology. Notably, it has been incorporated into inhibitors of Checkpoint Kinase 1 (CHK1) and Phosphoinositide 3-kinase delta (PI3K δ).^[1]

- **Development of Drugs for Neurological Disorders:** The piperidine scaffold is a common motif in centrally active agents, and **(S)-1-Boc-3-aminopiperidine** provides a synthetically accessible route to novel drug candidates targeting neurological diseases.
- **Peptide Synthesis:** It can be used to introduce conformational constraints and improve the metabolic stability and bioactivity of peptide-based therapeutics.
- **Structure-Activity Relationship (SAR) Studies:** Researchers utilize this compound to systematically explore the SAR of a lead compound by modifying the piperidine moiety, aiding in the design of more potent and selective drug candidates.

Featured Application: Synthesis of a CHK1 Inhibitor (AZD7762 Analog)

Checkpoint Kinase 1 (CHK1) is a critical component of the DNA damage response pathway, and its inhibition can sensitize cancer cells to chemotherapy and radiation. **(S)-1-Boc-3-aminopiperidine** is a key structural component of potent CHK1 inhibitors such as AZD7762.^[2]^[3]

Experimental Protocol: Synthesis of (S)-5-(3-Fluorophenyl)-N-(piperidin-3-yl)-3-ureidothiophene-2-carboxamide (AZD7762)

This protocol outlines the key steps in the synthesis of AZD7762, a potent CHK1 inhibitor, utilizing **(S)-1-Boc-3-aminopiperidine**. The synthesis involves a Weinreb amidation, followed by a Suzuki cross-coupling reaction and final deprotection of the Boc group.^[2]

Step 1: Weinreb Amidation

- To a solution of methyl 3-ureido-2-thiophenecarboxylate in a suitable solvent (e.g., THF), add a solution of trimethylaluminum in hexanes at 0 °C.
- After stirring for 30 minutes, add **(S)-1-Boc-3-aminopiperidine** to the reaction mixture.
- Allow the reaction to warm to room temperature and stir for 12-16 hours.

- Quench the reaction by the slow addition of a saturated aqueous solution of sodium bicarbonate.
- Extract the product with ethyl acetate, dry the organic layer over anhydrous sodium sulfate, and concentrate under reduced pressure to yield the thiophene amide intermediate.

Step 2: Suzuki Cross-Coupling

- To a solution of the thiophene amide from Step 1 in a mixture of toluene and ethanol, add 3-fluorophenylboronic acid, potassium carbonate, and tetrakis(triphenylphosphine)palladium(0).
- Heat the reaction mixture to reflux (approximately 80-90 °C) for 4-6 hours.
- Cool the reaction to room temperature and filter through a pad of celite.
- Concentrate the filtrate under reduced pressure and purify the residue by column chromatography to afford the arylthiophene product.

Step 3: Boc Deprotection

- Dissolve the arylthiophene product from Step 2 in a solution of hydrochloric acid in dioxane (e.g., 4 M).
- Stir the reaction mixture at room temperature for 1-2 hours.
- Concentrate the reaction mixture under reduced pressure.
- Triturate the resulting solid with diethyl ether and collect the precipitate by filtration to yield the final product, (S)-5-(3-Fluorophenyl)-N-(piperidin-3-yl)-3-ureidothiophene-2-carboxamide hydrochloride.

Quantitative Data

The following table summarizes the in vitro activity of AZD7762 and related analogs, synthesized using **(S)-1-Boc-3-aminopiperidine**, against CHK1.

Compound	CHK1 IC ₅₀ (nM)
AZD7762 (4)	<1
Analog 12a	<1
Analog 12b	2
Analog 12c	1
Analog 12d	1
Analog 12e	2
Analog 12f	1
Analog 12g	2
Analog 12h	1
Analog 12i	2
Analog 12j	1

Data sourced from the Journal of Medicinal Chemistry.[2]

Signaling Pathway Diagrams

CHK1 Signaling Pathway in DNA Damage Response

The following diagram illustrates the central role of CHK1 in the DNA damage response (DDR) pathway. Upon DNA damage, ATR kinase is activated and subsequently phosphorylates and activates CHK1. Activated CHK1 then phosphorylates downstream targets to induce cell cycle arrest, allowing time for DNA repair.[4][5][6][7][8]

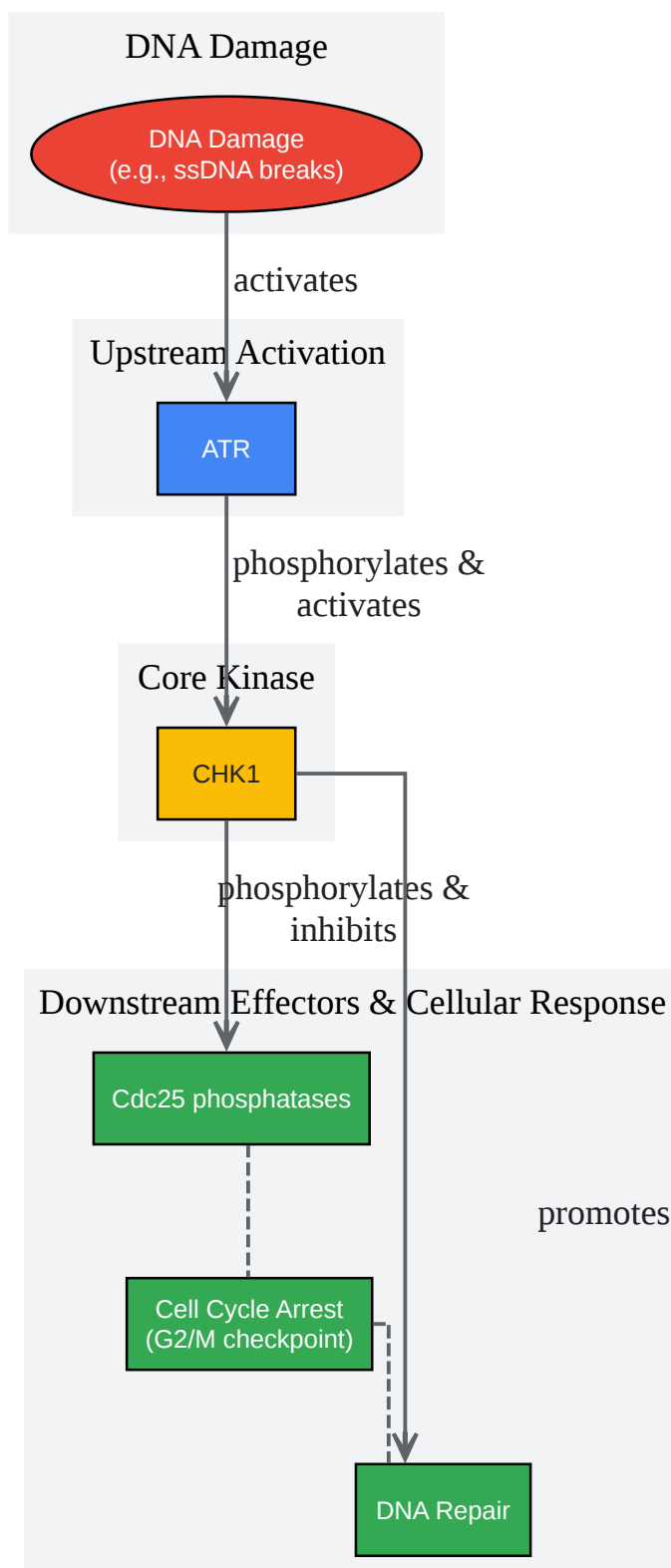

[Click to download full resolution via product page](#)

Caption: Simplified CHK1 signaling pathway in response to DNA damage.

PI3K δ Signaling Pathway in B-Cells

The diagram below depicts a simplified representation of the PI3K δ signaling pathway in B-cells. Activation of the B-cell receptor (BCR) leads to the activation of PI3K δ , which in turn triggers a cascade of downstream signaling events, ultimately promoting cell survival, proliferation, and differentiation.[\[9\]](#)[\[10\]](#)[\[11\]](#)[\[12\]](#)[\[13\]](#)

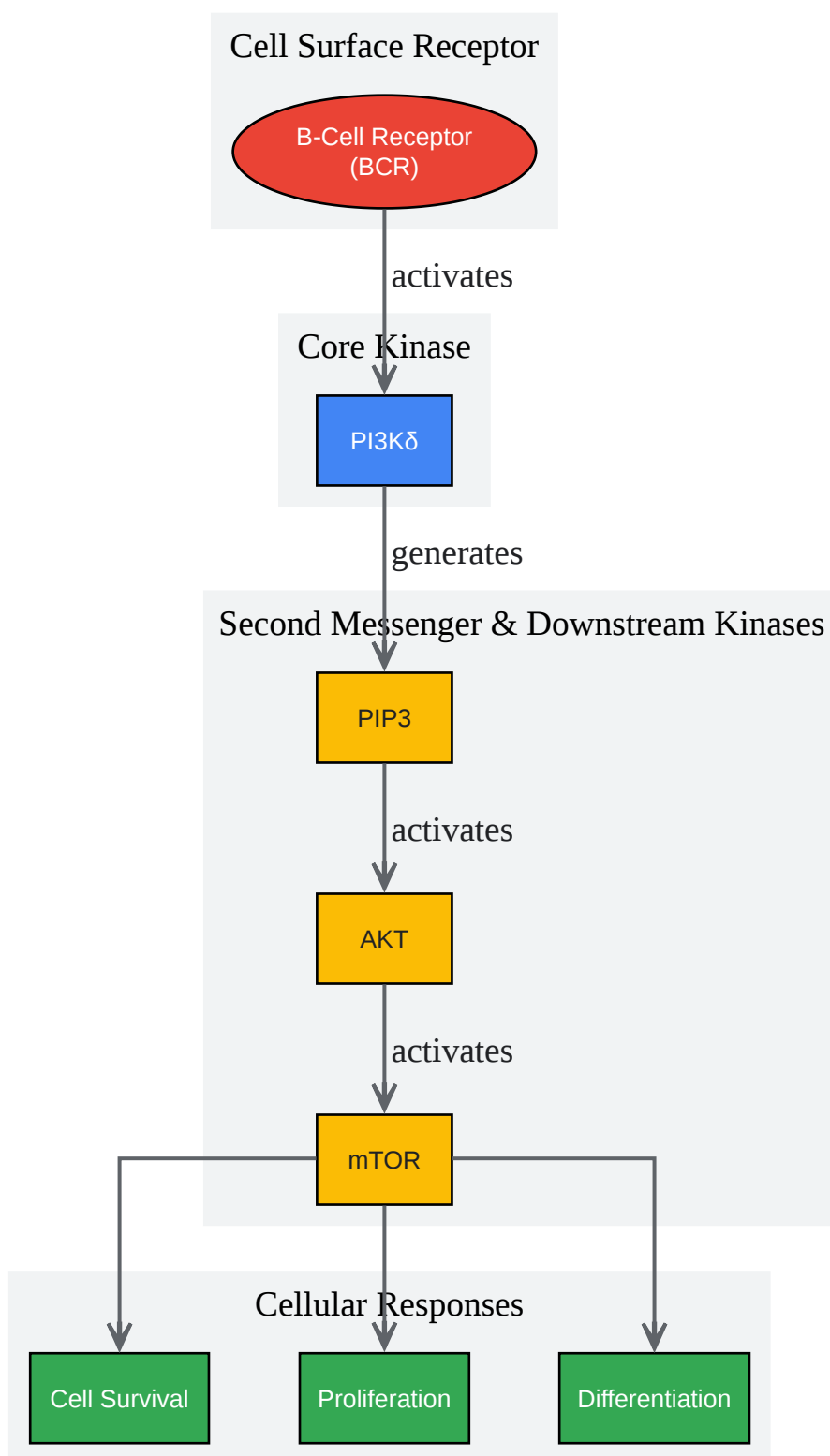

[Click to download full resolution via product page](#)

Caption: Simplified PI3K δ signaling pathway in B-cell activation.

Need Custom Synthesis?

BenchChem offers custom synthesis for rare earth carbides and specific isotopic labeling.

Email: info@benchchem.com or [Request Quote Online](#).

References

- 1. medchemexpress.com [medchemexpress.com]
- 2. pubs.acs.org [pubs.acs.org]
- 3. researchgate.net [researchgate.net]
- 4. Checkpoint kinase 1 in DNA damage response and cell cycle regulation - PMC [pmc.ncbi.nlm.nih.gov]
- 5. The ATM-Chk2 and ATR-Chk1 pathways in DNA damage signaling and cancer - PubMed [pubmed.ncbi.nlm.nih.gov]
- 6. New Insights into Checkpoint Kinase 1 (Chk1) in the DNA Damage Response (DDR) Signaling Network: Rationale for Employing Chk1 Inhibitors in Cancer Therapeutics - PMC [pmc.ncbi.nlm.nih.gov]
- 7. creative-diagnostics.com [creative-diagnostics.com]
- 8. CHEK1 - Wikipedia [en.wikipedia.org]
- 9. medchemexpress.com [medchemexpress.com]
- 10. Modulating the PI3K Signalling Pathway in Activated PI3K Delta Syndrome: a Clinical Perspective - PubMed [pubmed.ncbi.nlm.nih.gov]
- 11. researchgate.net [researchgate.net]
- 12. The PI3K pathway in human disease - PMC [pmc.ncbi.nlm.nih.gov]
- 13. Akt/PKB signaling pathway - Wikipedia [en.wikipedia.org]
- To cite this document: BenchChem. [Application Notes and Protocols: (S)-1-Boc-3-aminopiperidine in Medicinal Chemistry]. BenchChem, [2025]. [Online PDF]. Available at: [https://www.benchchem.com/product/b046749#s-1-boc-3-aminopiperidine-in-medicinal-chemistry-applications]

Disclaimer & Data Validity:

The information provided in this document is for Research Use Only (RUO) and is strictly not intended for diagnostic or therapeutic procedures. While BenchChem strives to provide accurate protocols, we make no warranties, express or implied, regarding the fitness of this product for every specific experimental setup.

Technical Support: The protocols provided are for reference purposes. Unsure if this reagent suits your experiment? [[Contact our Ph.D. Support Team for a compatibility check](#)]

Need Industrial/Bulk Grade? [Request Custom Synthesis Quote](#)

BenchChem

Our mission is to be the trusted global source of essential and advanced chemicals, empowering scientists and researchers to drive progress in science and industry.

Contact

Address: 3281 E Guasti Rd
Ontario, CA 91761, United States
Phone: (601) 213-4426
Email: info@benchchem.com