

Application Notes and Protocols: Fungicidal Activity of Modified Cyclopenta[c]pyridines

Author: BenchChem Technical Support Team. **Date:** December 2025

Compound of Interest

Compound Name: 5H-Cyclopenta[c]pyridin-7(6H)-one

Cat. No.: B1590900

[Get Quote](#)

For Researchers, Scientists, and Drug Development Professionals

These application notes provide a comprehensive overview of the fungicidal activity of modified cyclopenta[c]pyridine derivatives, a promising class of compounds with potential applications in agriculture and medicine. This document includes a summary of their biological activity, detailed experimental protocols for their evaluation, and a proposed mechanism of action.

Introduction

Cyclopenta[c]pyridine derivatives, particularly those with aryl modifications, have emerged as a significant area of interest in the development of novel agrochemicals.^{[1][2]} Inspired by the natural product cerbinal, these compounds have demonstrated a broad spectrum of biological activities, including antiviral, insecticidal, and notably, fungicidal properties.^{[1][2]} This document focuses on the fungicidal applications of these compounds, providing researchers with the necessary information to explore their potential further.

Data Presentation: Fungicidal Activity

The fungicidal efficacy of modified cyclopenta[c]pyridines has been demonstrated against several economically important plant pathogens. The following table summarizes the available quantitative data for a representative compound.

Compound ID	Fungal Species	Concentration (µg/mL)	Inhibition Ratio (%)	Reference
4i (3,4,5-trifluorophenyl derivative)	Sclerotinia sclerotiorum	50	91.9	[3]
Botrytis cinerea	50	75.0	[3]	
Phytophthora infestans	50	62.5	[3]	

Experimental Protocols

Detailed methodologies are crucial for the accurate assessment and comparison of the fungicidal activity of novel compounds. The following protocols are based on established methods for antifungal susceptibility testing and can be adapted for the evaluation of modified cyclopenta[c]pyridines.

Protocol 1: In Vitro Antifungal Susceptibility Testing using the Poisoned Food Technique

This method is suitable for determining the inhibitory effects of the compounds on the mycelial growth of filamentous fungi such as *Sclerotinia sclerotiorum* and *Botrytis cinerea*.

Materials:

- Potato Dextrose Agar (PDA)
- Test compounds (modified cyclopenta[c]pyridines)
- Dimethyl sulfoxide (DMSO) for stock solution preparation
- Sterile Petri dishes (90 mm)
- Cultures of *Sclerotinia sclerotiorum* and *Botrytis cinerea* on PDA
- Sterile cork borer (5 mm diameter)

- Incubator

Procedure:

- Preparation of Stock Solutions: Dissolve the test compounds in DMSO to a concentration of 10 mg/mL.
- Preparation of Poisoned Media: Autoclave the PDA medium and allow it to cool to approximately 50-60°C. Add the appropriate volume of the stock solution of the test compound to the molten PDA to achieve the desired final concentrations (e.g., 10, 25, 50, 100 µg/mL). Also, prepare a control plate containing the same concentration of DMSO without the test compound.
- Pouring Plates: Pour the amended and control PDA into sterile Petri dishes and allow them to solidify.
- Inoculation: Using a sterile cork borer, take a 5 mm mycelial disc from the edge of an actively growing fungal culture and place it in the center of each test and control plate.
- Incubation: Incubate the plates at 25 ± 2°C in the dark.
- Data Collection: Measure the radial growth of the fungal colony in two perpendicular directions at regular intervals (e.g., 24, 48, 72 hours) until the colony in the control plate reaches the edge of the dish.
- Calculation of Inhibition: Calculate the percentage of mycelial growth inhibition using the following formula: $\text{Inhibition (\%)} = [(C - T) / C] \times 100$ Where C is the average diameter of the fungal colony in the control plate, and T is the average diameter of the fungal colony in the treated plate.

Protocol 2: In Vitro Antifungal Susceptibility Testing for *Phytophthora infestans*

A modified poisoned food technique is often used for oomycetes like *Phytophthora infestans*.

Materials:

- Rye A agar or V8 juice agar
- Test compounds
- DMSO
- Sterile Petri dishes
- Actively growing cultures of *Phytophthora infestans*
- Sterile cork borer
- Incubator

Procedure:

- Media and Compound Preparation: Follow steps 1 and 2 from Protocol 1, using Rye A agar or V8 juice agar instead of PDA.
- Inoculation: Inoculate the center of the plates with a 5 mm mycelial plug from a 7-10 day old culture of *P. infestans*.
- Incubation: Incubate the plates at 18-20°C in the dark.
- Data Analysis: Measure the colony diameter and calculate the inhibition percentage as described in Protocol 1.

Protocol 3: Broth Microdilution Method for MIC Determination

This method is used to determine the Minimum Inhibitory Concentration (MIC) of the compounds and is particularly useful for high-throughput screening. This protocol is based on the guidelines from the Clinical and Laboratory Standards Institute (CLSI) M38-A2 for filamentous fungi.^{[2][4]}

Materials:

- RPMI-1640 medium with L-glutamine, without bicarbonate, buffered with MOPS.

- Test compounds
- DMSO
- Sterile 96-well microtiter plates
- Fungal spore suspension (e.g., *Botrytis cinerea*)
- Spectrophotometer or microplate reader

Procedure:

- Preparation of Fungal Inoculum: Prepare a spore suspension from a 7-10 day old culture in sterile saline with 0.05% Tween 80. Adjust the spore concentration to 0.4×10^4 to 5×10^4 CFU/mL in RPMI-1640 medium.
- Preparation of Compound Dilutions: Perform serial two-fold dilutions of the test compounds in RPMI-1640 in the 96-well plates to achieve a range of concentrations.
- Inoculation: Add the fungal inoculum to each well. Include a growth control (medium with inoculum and DMSO) and a sterility control (medium only).
- Incubation: Incubate the plates at 25-28°C for 48-72 hours.
- MIC Determination: The MIC is the lowest concentration of the compound that causes complete inhibition of visible growth. This can be determined visually or by measuring the absorbance at a specific wavelength (e.g., 530 nm).

Synthesis of Modified Cyclopenta[c]pyridines

The synthesis of 5-aryl-cyclopenta[c]pyridine derivatives typically starts from the natural product carbinal.^[5] A general synthetic scheme is outlined below.

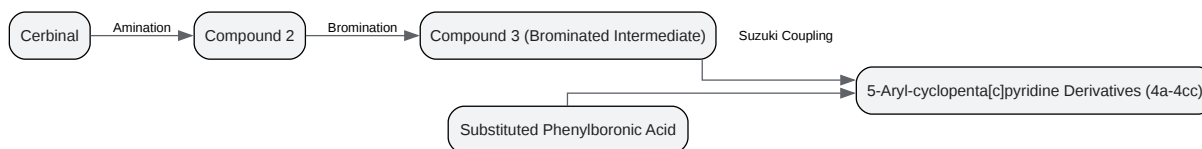

[Click to download full resolution via product page](#)

General synthetic workflow for 5-aryl-cyclopenta[c]pyridines.

Proposed Mechanism of Action

The precise molecular target for the fungicidal activity of modified cyclopenta[c]pyridines has not yet been fully elucidated. However, based on the known mechanisms of other pyridine-based fungicides, a plausible hypothesis is the inhibition of key fungal enzymes.[6] Many pyridine derivatives are known to target the fungal respiratory chain, specifically the succinate dehydrogenase (SDH) complex (Complex II).[6]

The proposed mechanism involves the binding of the cyclopenta[c]pyridine derivative to the ubiquinone-binding site of the SDH complex, thereby blocking the electron transport chain. This disruption of cellular respiration leads to a depletion of ATP, ultimately causing fungal cell death.

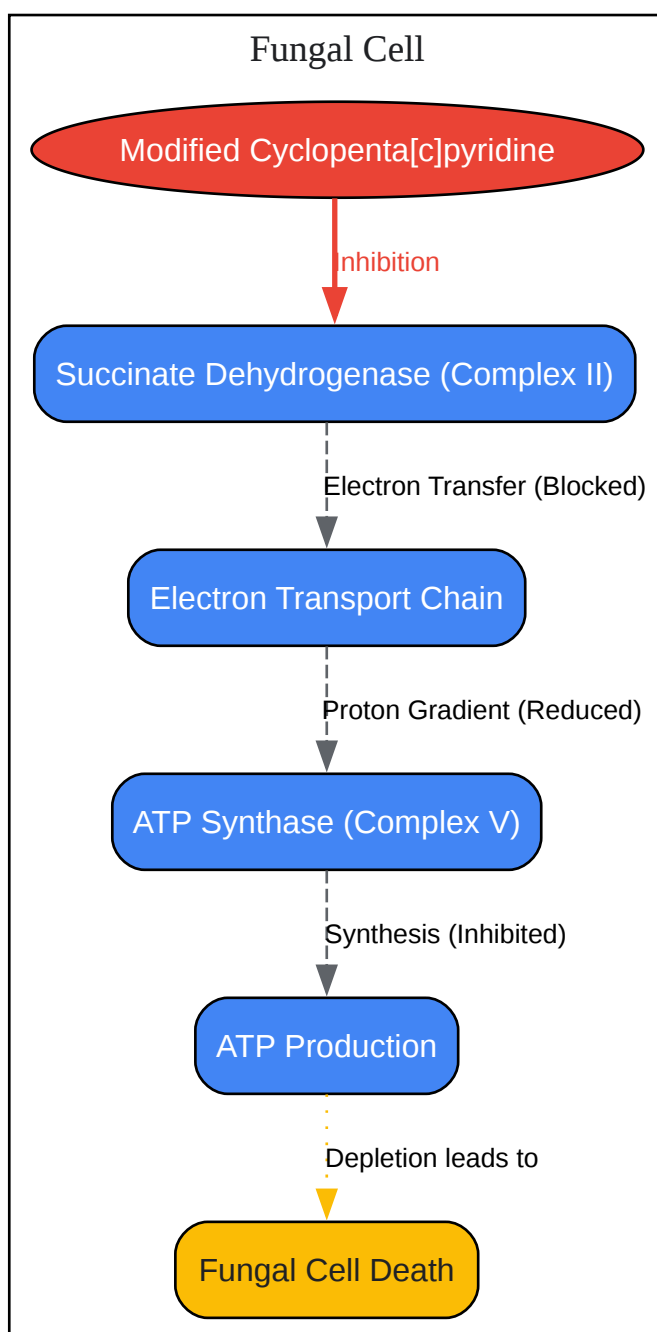

[Click to download full resolution via product page](#)

Proposed mechanism of action via SDH inhibition.

Experimental Workflow Visualization

The following diagram illustrates the logical flow of experiments for the evaluation of the fungicidal activity of novel modified cyclopenta[c]pyridine derivatives.

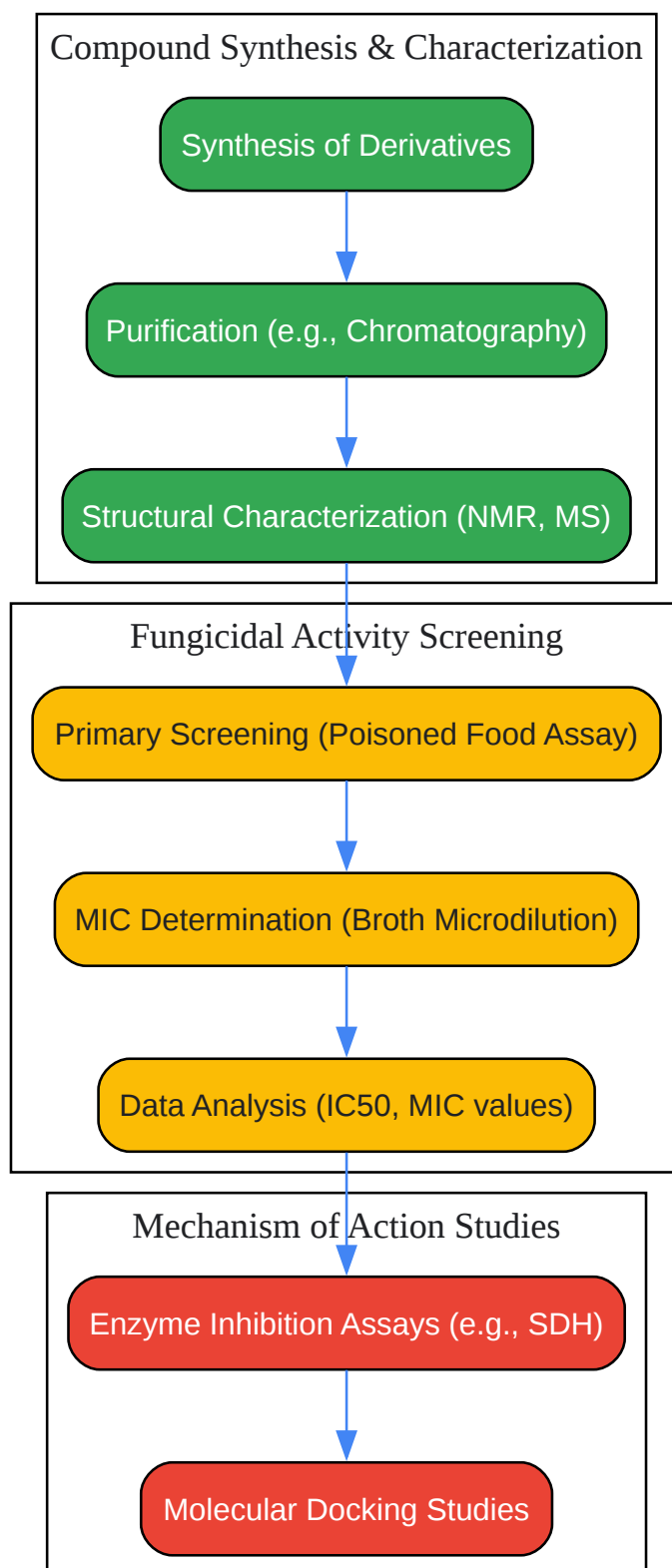

[Click to download full resolution via product page](#)

Workflow for fungicidal evaluation of new compounds.

Need Custom Synthesis?

BenchChem offers custom synthesis for rare earth carbides and specific isotopic labeling.

Email: info@benchchem.com or [Request Quote Online](#).

References

- 1. M51 | Method for Antifungal Disk Diffusion Susceptibility Testing of Nondermatophyte Filamentous Fungi [clsi.org]
- 2. M38 | Reference Method for Broth Dilution Antifungal Susceptibility Testing of Filamentous Fungi [clsi.org]
- 3. scielo.br [scielo.br]
- 4. img.antpedia.com [img.antpedia.com]
- 5. njccwei.com [njccwei.com]
- 6. Discovery of novel pyridine carboxamides with antifungal activity as potential succinate dehydrogenase inhibitors - PMC [pmc.ncbi.nlm.nih.gov]
- To cite this document: BenchChem. [Application Notes and Protocols: Fungicidal Activity of Modified Cyclopenta[c]pyridines]. BenchChem, [2025]. [Online PDF]. Available at: [https://www.benchchem.com/product/b1590900#fungicidal-activity-of-modified-cyclopenta-c-pyridines]

Disclaimer & Data Validity:

The information provided in this document is for Research Use Only (RUO) and is strictly not intended for diagnostic or therapeutic procedures. While BenchChem strives to provide accurate protocols, we make no warranties, express or implied, regarding the fitness of this product for every specific experimental setup.

Technical Support: The protocols provided are for reference purposes. Unsure if this reagent suits your experiment? [[Contact our Ph.D. Support Team for a compatibility check](#)]

Need Industrial/Bulk Grade? [Request Custom Synthesis Quote](#)

BenchChem

Our mission is to be the trusted global source of essential and advanced chemicals, empowering scientists and researchers to drive progress in science and industry.

Contact

Address: 3281 E Guasti Rd

Ontario, CA 91761, United States

Phone: (601) 213-4426

Email: info@benchchem.com