

# Application Notes and Protocols: Evaluating VEGFR-IN-6 in 3D Spheroid Angiogenesis Models

**Author:** BenchChem Technical Support Team. **Date:** December 2025

## Compound of Interest

Compound Name: VEGFR-IN-6

Cat. No.: B2353957

[Get Quote](#)

Audience: Researchers, scientists, and drug development professionals.

## Introduction

Angiogenesis, the formation of new blood vessels from pre-existing ones, is a critical process in tumor growth and metastasis. The Vascular Endothelial Growth Factor (VEGF) signaling pathway is a key regulator of angiogenesis, making it a prime target for anti-cancer therapies. Three-dimensional (3D) spheroid angiogenesis models offer a more physiologically relevant in vitro system to study anti-angiogenic compounds compared to traditional 2D cell cultures. This document provides detailed application notes and protocols for evaluating the efficacy of **VEGFR-IN-6**, a hypothetical inhibitor of VEGF receptors, using a 3D endothelial cell spheroid sprouting assay.

## Mechanism of Action

**VEGFR-IN-6** is designed to inhibit the tyrosine kinase activity of VEGF receptors (VEGFRs), primarily VEGFR-2, which is the main mediator of the pro-angiogenic effects of VEGF-A. By blocking the ATP-binding site of the receptor's intracellular kinase domain, **VEGFR-IN-6** prevents autophosphorylation and the activation of downstream signaling cascades. This ultimately leads to the inhibition of endothelial cell proliferation, migration, and tube formation, which are all critical steps in angiogenesis.

## Quantitative Data

The following tables summarize representative quantitative data on the effect of a VEGFR inhibitor on endothelial cell sprouting in a 3D spheroid angiogenesis model. This data is based on studies with the known VEGFR inhibitor, Sunitinib, and is intended to provide an expected range of activity for a compound like **VEGFR-IN-6**.<sup>[1]</sup>

Table 1: Effect of **VEGFR-IN-6** on Cumulative Sprout Length in VEGF-A Stimulated Endothelial Cell Spheroids<sup>[1]</sup>

VEGFR-IN-6 Concentration ( $\mu\text{M}$ )	Mean Cumulative Sprout Length ( $\mu\text{m}$ ) per Spheroid	Standard Deviation ( $\mu\text{m}$ )	% Inhibition
0 (Vehicle Control)	1250	150	0%
0.01	1100	130	12%
0.1	750	90	40%
1	300	45	76%
10	50	15	96%

Table 2: Effect of **VEGFR-IN-6** on the Number of Sprouts per Spheroid in VEGF-A Stimulated Endothelial Cell Spheroids

VEGFR-IN-6 Concentration ( $\mu\text{M}$ )	Mean Number of Sprouts per Spheroid	Standard Deviation	% Inhibition
0 (Vehicle Control)	25	4	0%
0.01	22	3	12%
0.1	15	2	40%
1	6	1	76%
10	1	0.5	96%

# Experimental Protocols

## Protocol 1: Endothelial Cell Spheroid Formation

This protocol describes the generation of endothelial cell spheroids using the hanging drop method.

Materials:

- Human Umbilical Vein Endothelial Cells (HUVECs)
- Endothelial Cell Growth Medium (EGM-2)
- Phosphate-Buffered Saline (PBS)
- Trypsin-EDTA
- Fetal Bovine Serum (FBS)
- Methylcellulose stock solution
- Sterile petri dishes (10 cm)
- Sterile multichannel pipette reservoir

Procedure:

- Culture HUVECs in EGM-2 medium until they reach 80-90% confluency.
- Wash the cells twice with PBS and detach them using Trypsin-EDTA.
- Neutralize the trypsin with EGM-2 medium containing 10% FBS and centrifuge the cells at 200 x g for 5 minutes.
- Resuspend the cell pellet in EGM-2 medium and count the cells.
- Prepare a cell suspension of  $2.5 \times 10^4$  cells/mL in EGM-2 medium containing 20% (v/v) methylcellulose stock solution. This will result in spheroids of approximately 500 cells when using 20  $\mu$ L drops.

- Pipette 20  $\mu$ L drops of the cell suspension onto the lid of a 10 cm petri dish.
- Carefully invert the lid and place it on top of the petri dish containing 5 mL of PBS to create a humidified chamber.
- Incubate the hanging drops for 24 hours at 37°C in a 5% CO<sub>2</sub> incubator to allow for spheroid formation.

## Protocol 2: 3D Spheroid-Based Sprouting Angiogenesis Assay

This protocol details the embedding of spheroids in an extracellular matrix and the subsequent treatment with **VEGFR-IN-6**.

Materials:

- Endothelial cell spheroids (from Protocol 1)
- Collagen Type I, rat tail
- 10x M199 medium
- 1 N NaOH
- Basal medium (e.g., EBM-2)
- VEGF-A (recombinant human)
- **VEGFR-IN-6** (dissolved in a suitable solvent, e.g., DMSO)
- 24-well tissue culture plate
- Ice

Procedure:

- Prepare the Collagen Gel: On ice, mix 8 parts Collagen Type I, 1 part 10x M199 medium, and 1 part of sterile, distilled water. Neutralize the solution by adding 1 N NaOH dropwise

until the color of the medium turns from yellow to pink. Keep the collagen solution on ice to prevent premature polymerization.

- **Harvest Spheroids:** Gently wash the spheroids from the petri dish lid with 10 mL of PBS and transfer them to a 15 mL conical tube.
- **Centrifuge and Resuspend:** Centrifuge the spheroids at 200 x g for 5 minutes. Carefully aspirate the supernatant and resuspend the spheroid pellet in the prepared neutralized collagen solution. Aim for a concentration of approximately 10-15 spheroids per 100  $\mu$ L of collagen gel.
- **Plate the Spheroid-Collagen Mixture:** Pipette 100  $\mu$ L of the spheroid-collagen mixture into each well of a pre-chilled 24-well plate.
- **Polymerization:** Incubate the plate at 37°C in a 5% CO<sub>2</sub> incubator for 30-60 minutes to allow the collagen to polymerize.
- **Prepare Treatment Media:** Prepare the treatment media by diluting VEGF-A to a final concentration of 50 ng/mL in basal medium. For the experimental groups, add the desired concentrations of **VEGFR-IN-6** to the VEGF-A containing medium. Include a vehicle control (medium with VEGF-A and the same concentration of solvent used for **VEGFR-IN-6**).
- **Add Treatment Media:** Gently add 500  $\mu$ L of the respective treatment media on top of the polymerized collagen gel in each well.
- **Incubation:** Incubate the plate for 24-48 hours at 37°C in a 5% CO<sub>2</sub> incubator.
- **Imaging and Analysis:** After incubation, capture images of the spheroids using an inverted microscope. Quantify the angiogenic response by measuring the number of sprouts per spheroid and the cumulative sprout length for each spheroid using image analysis software (e.g., ImageJ).

## Mandatory Visualizations

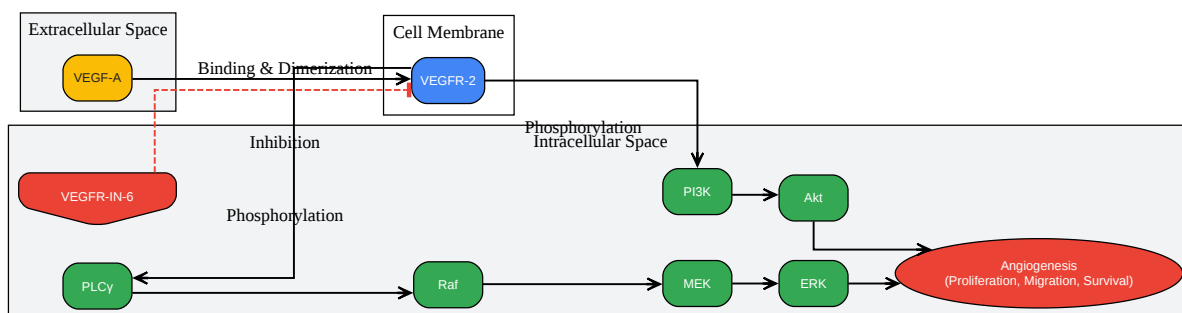

[Click to download full resolution via product page](#)

Caption: VEGFR-2 signaling pathway and the inhibitory action of **VEGFR-IN-6**.

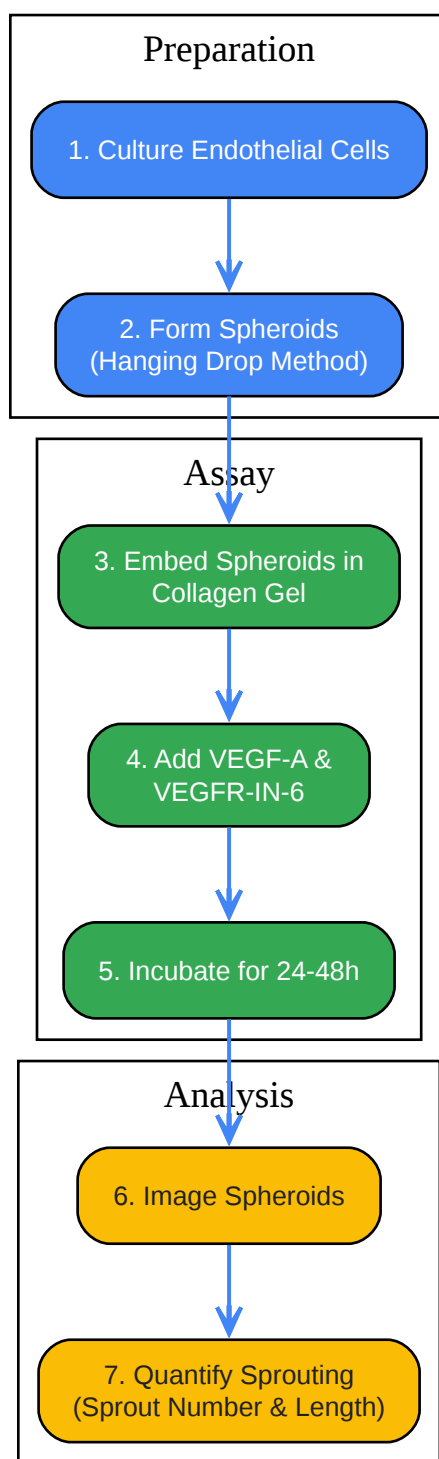

[Click to download full resolution via product page](#)

Caption: Experimental workflow for the 3D spheroid angiogenesis assay.

### Need Custom Synthesis?

BenchChem offers custom synthesis for rare earth carbides and specific isotopic labeling.

Email: [info@benchchem.com](mailto:info@benchchem.com) or [Request Quote Online](#).

## References

- 1. An Automated Quantification Tool for Angiogenic Sprouting From Endothelial Spheroids - PMC [pmc.ncbi.nlm.nih.gov]
- To cite this document: BenchChem. [Application Notes and Protocols: Evaluating VEGFR-IN-6 in 3D Spheroid Angiogenesis Models]. BenchChem, [2025]. [Online PDF]. Available at: [https://www.benchchem.com/product/b2353957#vegfr-in-6-in-3d-spheroid-angiogenesis-models]

### Disclaimer & Data Validity:

The information provided in this document is for Research Use Only (RUO) and is strictly not intended for diagnostic or therapeutic procedures. While BenchChem strives to provide accurate protocols, we make no warranties, express or implied, regarding the fitness of this product for every specific experimental setup.

**Technical Support:** The protocols provided are for reference purposes. Unsure if this reagent suits your experiment? [[Contact our Ph.D. Support Team for a compatibility check](#)]

**Need Industrial/Bulk Grade?** [Request Custom Synthesis Quote](#)

## BenchChem

Our mission is to be the trusted global source of essential and advanced chemicals, empowering scientists and researchers to drive progress in science and industry.

### Contact

Address: 3281 E Guasti Rd  
Ontario, CA 91761, United States  
Phone: (601) 213-4426  
Email: [info@benchchem.com](mailto:info@benchchem.com)