

Application Notes and Protocols: Elucidating Anti-Inflammatory Mechanisms with Curcumin

Author: BenchChem Technical Support Team. **Date:** December 2025

Compound of Interest

Compound Name: *Curcumaromin C*

Cat. No.: B14756242

[Get Quote](#)

For the attention of: Researchers, scientists, and drug development professionals.

Topic: Utilization of Curcumin and its Analogs in the Study of Anti-inflammatory Mechanisms.

Disclaimer: Initial searches for "**Curcumaromin C**" did not yield specific scientific literature or data. The following application notes and protocols are based on the extensive research available for curcumin, a closely related and well-studied anti-inflammatory compound. It is crucial to verify the specific properties of any particular curcumin analog before applying these protocols.

Introduction

Curcumin, a polyphenol extracted from the rhizome of *Curcuma longa*, has garnered significant scientific interest for its potent anti-inflammatory properties.^{[1][2][3][4]} It modulates a wide array of molecular targets and signaling pathways implicated in the inflammatory response, making it a valuable tool for investigating the mechanisms of inflammation and for the development of novel anti-inflammatory therapeutics.^{[1][2][5][6]} This document provides an overview of the key anti-inflammatory mechanisms of curcumin and detailed protocols for its application in *in vitro* and *in vivo* studies.

Key Anti-Inflammatory Mechanisms of Curcumin

Curcumin exerts its anti-inflammatory effects through the modulation of several key signaling pathways and molecular targets:

- **Inhibition of the NF- κ B Signaling Pathway:** Nuclear Factor-kappa B (NF- κ B) is a critical transcription factor that regulates the expression of numerous pro-inflammatory genes, including cytokines, chemokines, and adhesion molecules.[7][8][9][10] Curcumin has been shown to inhibit NF- κ B activation by preventing the phosphorylation and subsequent degradation of its inhibitory subunit, I κ B α . [7][8] This action blocks the nuclear translocation of NF- κ B and subsequent transcription of pro-inflammatory genes.[7][8]
- **Modulation of the MAPK Signaling Pathway:** The Mitogen-Activated Protein Kinase (MAPK) pathway, which includes cascades such as ERK1/2, JNK, and p38, plays a pivotal role in cellular responses to inflammatory stimuli.[11][12][13][14] Curcumin can modulate MAPK signaling, often by inhibiting the phosphorylation of key kinases in these pathways, thereby reducing the expression of inflammatory mediators.[11][12]
- **Inhibition of Pro-inflammatory Enzymes:** Curcumin can directly inhibit the activity of enzymes that are crucial for the synthesis of inflammatory mediators. These include cyclooxygenase-2 (COX-2) and lipoxygenase (LOX), which are involved in the production of prostaglandins and leukotrienes, respectively, and inducible nitric oxide synthase (iNOS), which produces nitric oxide, a pro-inflammatory molecule.[3]
- **Antioxidant Activity:** Curcumin possesses potent antioxidant properties, enabling it to neutralize reactive oxygen species (ROS).[3] By scavenging free radicals, curcumin can mitigate oxidative stress, which is a key contributor to the inflammatory process.

Quantitative Data on the Anti-Inflammatory Effects of Curcumin and its Analogs

The following tables summarize quantitative data from various studies investigating the anti-inflammatory effects of curcumin and its analogs.

Table 1: Inhibition of NF- κ B Activity by Curcumin and its Analogs

Compound	Cell Line	Stimulus	IC50 for NF-κB Inhibition	Reference
Curcumin	RAW264.7 Macrophages	LPS (1 µg/mL)	>50 µM	[9][10]
EF24 (Curcumin Analog)	RAW264.7 Macrophages	LPS (1 µg/mL)	~35 µM	[9][10]
EF31 (Curcumin Analog)	RAW264.7 Macrophages	LPS (1 µg/mL)	~5 µM	[9][10]
BAT3 (Curcumin Analog)	K562 Leukemia Cells	TNF	~6 µM	[7]

Table 2: Effect of Curcumin on Pro-Inflammatory Cytokine Levels

Study Type	Model	Treatment	Cytokine	Result	Reference
In vivo	Mice with Acute Lung Injury	Curcumin	IL-6, TNF- α , CCL7	Significant reduction in serum concentrations	[15]
In vitro	LPS-stimulated RAW 264.7 Macrophages	50 μ M Curcumin	TNF- α (protein)	71% reduction	[16]
In vitro	LPS-stimulated RAW 264.7 Macrophages	100 μ M Curcumin	TNF- α (protein)	99% reduction	[16]
Clinical Trial	Adults Recovered from COVID-19 and Vaccinated	Curcumin	IL-6, MCP-1	Significantly lower post-trial concentrations	[17]
Meta-analysis of RCTs	Adults	Turmeric/Curcumin Supplementat ion	TNF- α	WMD: -3.48 pg/ml	[18]
Meta-analysis of RCTs	Adults	Turmeric/Curcumin Supplementat ion	IL-6	WMD: -1.31 pg/ml	[18]

Experimental Protocols

Protocol 1: In Vitro Assessment of NF- κ B Inhibition using a Reporter Gene Assay

Objective: To determine the inhibitory effect of a test compound (e.g., Curcumin) on NF- κ B activation in response to an inflammatory stimulus.

Materials:

- Cell line stably transfected with an NF- κ B reporter construct (e.g., HEK293-NF- κ B-luc)
- Cell culture medium (e.g., DMEM) with 10% FBS and 1% Penicillin-Streptomycin
- Test compound (Curcumin) dissolved in a suitable solvent (e.g., DMSO)
- Inflammatory stimulus (e.g., TNF- α)
- Luciferase Assay System
- Luminometer
- 96-well white, clear-bottom cell culture plates

Procedure:

- Seed the reporter cells in a 96-well plate at a density of 5×10^4 cells/well and allow them to adhere overnight.
- Prepare serial dilutions of the test compound in cell culture medium. The final solvent concentration should be kept constant across all wells (e.g., $<0.1\%$ DMSO).
- Remove the old medium from the cells and add the medium containing the different concentrations of the test compound. Include a vehicle control (solvent only).
- Incubate the cells with the test compound for a predetermined time (e.g., 1 hour).
- Add the inflammatory stimulus (e.g., TNF- α at a final concentration of 10 ng/mL) to all wells except the unstimulated control.
- Incubate the cells for an appropriate time to allow for reporter gene expression (e.g., 6-8 hours).

- Lyse the cells and measure the luciferase activity using a luminometer according to the manufacturer's protocol for the Luciferase Assay System.
- Normalize the luciferase activity to a measure of cell viability (e.g., using a CellTiter-Glo assay) to account for any cytotoxic effects of the compound.
- Calculate the percentage of NF- κ B inhibition for each concentration of the test compound relative to the stimulated vehicle control.
- Plot the percentage of inhibition against the compound concentration to determine the IC50 value.

Protocol 2: In Vivo Evaluation of Anti-Inflammatory Activity in a Mouse Model of Acute Lung Injury (ALI)

Objective: To assess the in vivo anti-inflammatory efficacy of a test compound (e.g., Curcumin) in a lipopolysaccharide (LPS)-induced ALI mouse model.

Materials:

- Male C57BL/6 mice (8-10 weeks old)
- Lipopolysaccharide (LPS) from *E. coli*
- Test compound (Curcumin) formulated for in vivo administration (e.g., in corn oil)
- Anesthesia (e.g., isoflurane)
- Bronchoalveolar lavage (BAL) fluid collection supplies
- ELISA kits for measuring cytokine levels (e.g., TNF- α , IL-6)
- Myeloperoxidase (MPO) activity assay kit
- Histology supplies (formalin, paraffin, H&E stain)

Procedure:

- Acclimatize the mice for at least one week before the experiment.
- Divide the mice into experimental groups (e.g., Vehicle + Saline, Vehicle + LPS, Curcumin + LPS).
- Pre-treat the mice with the test compound or vehicle at a specified dose and route of administration (e.g., oral gavage) for a defined period before LPS challenge.
- Induce ALI by intratracheal instillation of LPS (e.g., 5 mg/kg) under light anesthesia. Administer sterile saline to the control group.
- At a predetermined time point after LPS challenge (e.g., 24 hours), euthanize the mice.
- Collect blood via cardiac puncture for serum cytokine analysis.
- Perform bronchoalveolar lavage (BAL) to collect BAL fluid.
- Centrifuge the BAL fluid to separate the supernatant (for cytokine analysis) and the cell pellet (for cell counting and differential analysis).
- Harvest the lung tissue. A portion can be snap-frozen for MPO activity measurement, and another portion can be fixed in formalin for histological analysis.
- Measure the levels of pro-inflammatory cytokines (e.g., TNF- α , IL-6) in the serum and BAL fluid supernatant using ELISA kits.
- Determine the MPO activity in the lung homogenates as an indicator of neutrophil infiltration.
- Process the fixed lung tissue for histology and stain with H&E to assess the degree of lung inflammation and injury.
- Statistically analyze the data to compare the effects of the test compound with the vehicle control in the LPS-challenged group.

Visualizations

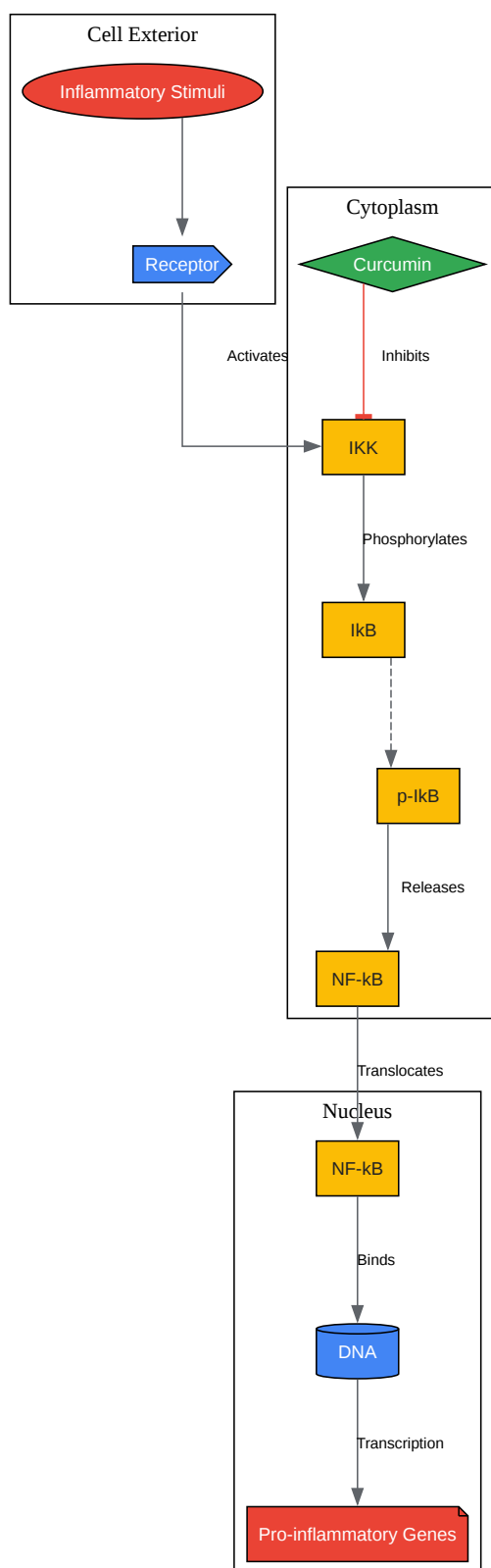

[Click to download full resolution via product page](#)

Caption: Curcumin inhibits the NF-κB signaling pathway.

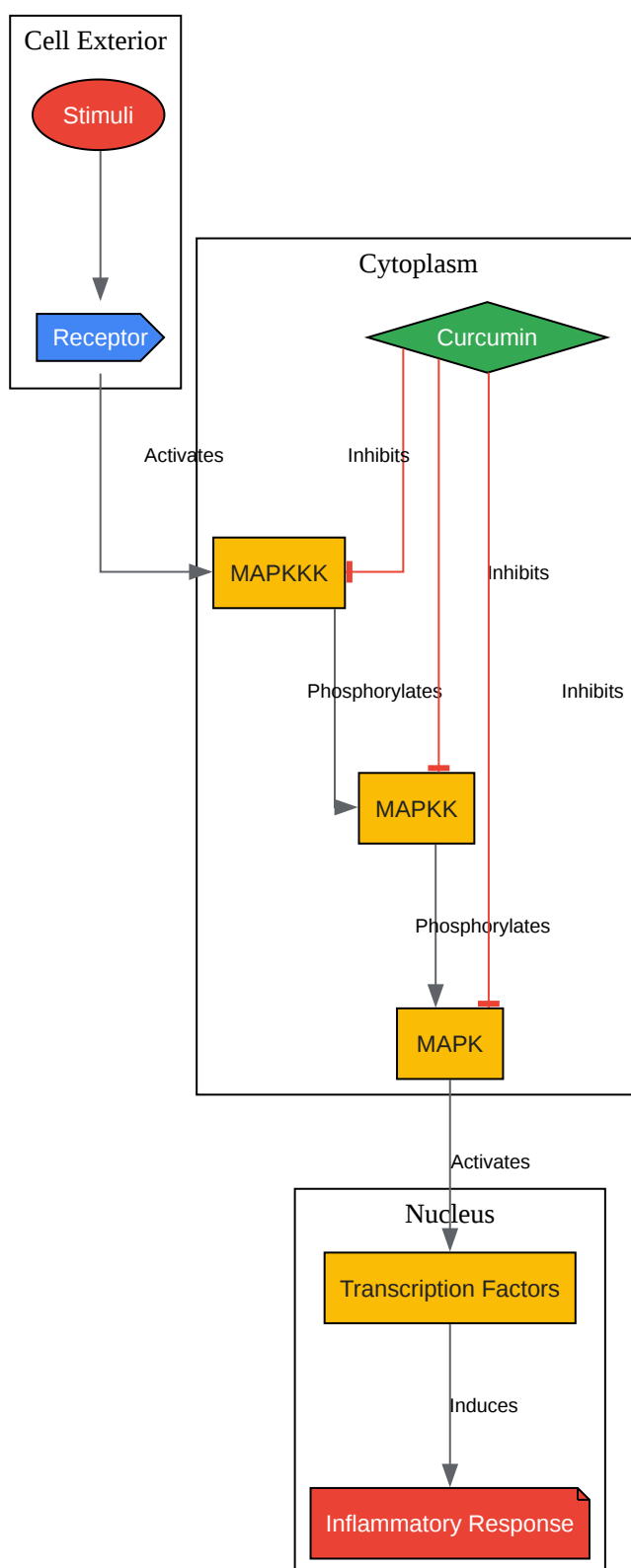

[Click to download full resolution via product page](#)

Caption: Curcumin modulates the MAPK signaling pathway.

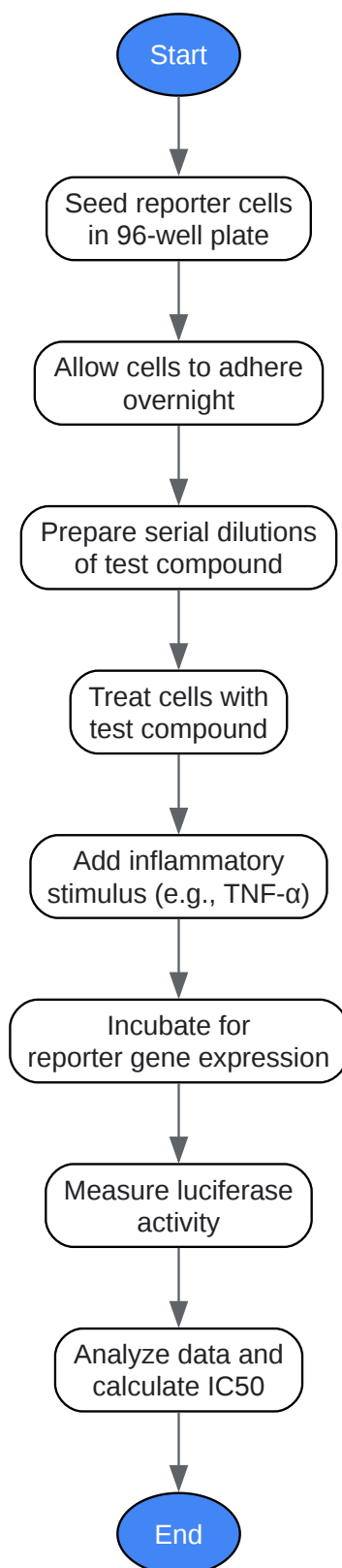

[Click to download full resolution via product page](#)

Caption: Experimental workflow for in vitro NF-κB inhibition assay.

Need Custom Synthesis?

BenchChem offers custom synthesis for rare earth carbides and specific isotopic labeling.

Email: info@benchchem.com or [Request Quote Online](#).

References

- 1. Curcumin: a modulator of inflammatory signaling pathways in the immune system | springermedicine.com [springermedicine.com]
- 2. Curcumin: a modulator of inflammatory signaling pathways in the immune system - PubMed [pubmed.ncbi.nlm.nih.gov]
- 3. Antioxidant and anti-inflammatory properties of curcumin - PubMed [pubmed.ncbi.nlm.nih.gov]
- 4. Anti-Inflammatory Effects of Curcumin in the Inflammatory Diseases: Status, Limitations and Countermeasures - PMC [pmc.ncbi.nlm.nih.gov]
- 5. Curcumin, Inflammation, and Chronic Diseases: How Are They Linked? - PMC [pmc.ncbi.nlm.nih.gov]
- 6. Molecular mechanism of curcumin action in signaling pathways: Review of the latest research - PubMed [pubmed.ncbi.nlm.nih.gov]
- 7. mdpi.com [mdpi.com]
- 8. researchgate.net [researchgate.net]
- 9. Inhibition of the NF- κ B signaling pathway by the curcumin analog, 3,5-Bis(2-pyridinylmethylidene)-4-piperidone (EF31): anti-inflammatory and anti-cancer properties - PMC [pmc.ncbi.nlm.nih.gov]
- 10. Inhibition of the NF- κ B signaling pathway by the curcumin analog, 3,5-Bis(2-pyridinylmethylidene)-4-piperidone (EF31): anti-inflammatory and anti-cancer properties - PubMed [pubmed.ncbi.nlm.nih.gov]
- 11. researchgate.net [researchgate.net]
- 12. Curcumin, a Curcuma longa constituent, acts on MAPK p38 pathway modulating COX-2 and iNOS expression in chronic experimental colitis - PubMed [pubmed.ncbi.nlm.nih.gov]
- 13. cicancer.org [cicancer.org]
- 14. news-medical.net [news-medical.net]
- 15. researchgate.net [researchgate.net]

- 16. Mechanism of the Anti-inflammatory Effect of Curcumin: PPAR- γ Activation - PMC [pmc.ncbi.nlm.nih.gov]
- 17. mdpi.com [mdpi.com]
- 18. Antioxidant and anti-inflammatory effects of curcumin/turmeric supplementation in adults: A GRADE-assessed systematic review and dose-response meta-analysis of randomized controlled trials - PubMed [pubmed.ncbi.nlm.nih.gov]
- To cite this document: BenchChem. [Application Notes and Protocols: Elucidating Anti-Inflammatory Mechanisms with Curcumin]. BenchChem, [2025]. [Online PDF]. Available at: [https://www.benchchem.com/product/b14756242#using-curcumaromin-c-to-study-anti-inflammatory-mechanisms]

Disclaimer & Data Validity:

The information provided in this document is for Research Use Only (RUO) and is strictly not intended for diagnostic or therapeutic procedures. While BenchChem strives to provide accurate protocols, we make no warranties, express or implied, regarding the fitness of this product for every specific experimental setup.

Technical Support: The protocols provided are for reference purposes. Unsure if this reagent suits your experiment? [[Contact our Ph.D. Support Team for a compatibility check](#)]

Need Industrial/Bulk Grade? [Request Custom Synthesis Quote](#)

BenchChem

Our mission is to be the trusted global source of essential and advanced chemicals, empowering scientists and researchers to drive progress in science and industry.

Contact

Address: 3281 E Guasti Rd
Ontario, CA 91761, United States
Phone: (601) 213-4426
Email: info@benchchem.com