

Application Notes and Protocols: DBCO-PEG4-TFP Ester for Live Cell Imaging

Author: BenchChem Technical Support Team. **Date:** December 2025

Compound of Interest

Compound Name: DBCO-PEG4-TFP ester

Cat. No.: B15290342

[Get Quote](#)

For Researchers, Scientists, and Drug Development Professionals

Introduction

DBCO-PEG4-TFP ester is a versatile heterobifunctional crosslinker that has emerged as a powerful tool in chemical biology and live-cell imaging. This reagent facilitates a two-step labeling strategy rooted in bioorthogonal chemistry, specifically the strain-promoted azide-alkyne cycloaddition (SPAAC), also known as copper-free click chemistry.[1][2] This approach allows for the precise and stable labeling of biomolecules in their native environment with minimal perturbation to cellular processes, making it ideal for dynamic studies in living systems. [1][2]

The **DBCO-PEG4-TFP ester** molecule features three key components:

- Dibenzocyclooctyne (DBCO): A cyclooctyne that reacts specifically and efficiently with azide groups without the need for a cytotoxic copper catalyst.[2] This bioorthogonal reaction forms a stable triazole linkage.[3]
- Tetrafluorophenyl (TFP) ester: An amine-reactive functional group that readily forms stable amide bonds with primary amines, such as those found on proteins and other biomolecules. [4]
- Polyethylene glycol (PEG4) spacer: A short, hydrophilic PEG linker that enhances solubility and minimizes steric hindrance, improving conjugation efficiency.[5]

This application note provides detailed protocols for using **DBCO-PEG4-TFP ester** in live-cell imaging applications, including the labeling of proteins and subsequent visualization on the surface of living cells.

Principle of the Two-Step Labeling Strategy

The use of **DBCO-PEG4-TFP ester** for live-cell imaging typically involves a two-step process:

- Modification of a biomolecule of interest with a DBCO group: A protein, antibody, or other amine-containing molecule is first reacted with **DBCO-PEG4-TFP ester**. The TFP ester forms a covalent amide bond with a primary amine on the target molecule, attaching the DBCO moiety.
- Labeling of live cells with an azide-functionalized probe: Live cells are metabolically engineered to express azide groups on their surface glycans by culturing them with an azide-modified sugar, such as N-azidoacetylmannosamine (Ac4ManNAz).^{[6][7]} The DBCO-modified biomolecule is then introduced to the azide-expressing cells, where the DBCO group reacts specifically with the azide via SPAAC, resulting in the covalent attachment of the biomolecule to the cell surface for subsequent imaging.

Data Presentation

Table 1: Recommended Reaction Parameters for Protein Labeling with **DBCO-PEG4-TFP Ester**

Parameter	Recommended Value	Notes
Protein Concentration	1–5 mg/mL[6]	Higher concentrations can improve conjugation efficiency.
Molar Excess of DBCO-PEG4-TFP Ester	10- to 40-fold[8]	The optimal ratio may need to be determined empirically.
Reaction Buffer	Amine-free buffer, pH 7.2-8.0[4]	e.g., Phosphate-Buffered Saline (PBS).
Reaction Time	1-2 hours at room temperature or overnight at 4°C[6][8]	Longer incubation times at lower temperatures can be effective.
Quenching	Addition of Tris buffer	To stop the reaction by consuming unreacted TFP ester.
Purification	Spin desalting columns or dialysis[6]	To remove excess, unreacted DBCO-PEG4-TFP ester.

Table 2: Parameters for Metabolic Labeling of Live Cells with Ac4ManNAz

Parameter	Recommended Value	Notes
Ac4ManNAz Concentration	10–50 μ M[6][7]	Concentration should be optimized for each cell line to maximize labeling and minimize cytotoxicity.[6]
Incubation Time	24–72 hours[4][5]	The optimal time depends on the cell type and its metabolic rate.
Cell Culture Conditions	Standard cell culture conditions (37°C, 5% CO ₂)	

Table 3: Parameters for SPAAC Reaction on Live Cells

Parameter	Recommended Value	Notes
DBCO-labeled Probe Concentration	10–20 μM [9]	The optimal concentration should be determined to maximize signal and minimize background.
Incubation Time	30–60 minutes[9][10]	The reaction is typically rapid.
Incubation Temperature	37°C[9]	
Washing	2-3 washes with PBS or cell culture medium[9][11]	To remove unbound DBCO-labeled probe.

Experimental Protocols

Protocol 1: Labeling of a Protein with DBCO-PEG4-TFP Ester

This protocol describes the general procedure for conjugating **DBCO-PEG4-TFP ester** to a protein containing primary amines.

Materials:

- Protein of interest (1-5 mg/mL in amine-free buffer like PBS, pH 7.2)
- **DBCO-PEG4-TFP ester**
- Anhydrous Dimethylsulfoxide (DMSO)
- Amine-free reaction buffer (e.g., PBS, pH 7.2-8.0)
- Quenching buffer (e.g., 1 M Tris-HCl, pH 8.0)
- Spin desalting columns

Procedure:

- Prepare the protein solution at a concentration of 1-5 mg/mL in an amine-free buffer.[6]

- Immediately before use, prepare a stock solution of **DBCO-PEG4-TFP ester** in anhydrous DMSO (e.g., 10 mM).
- Add a 10- to 40-fold molar excess of the **DBCO-PEG4-TFP ester** stock solution to the protein solution.[8]
- Incubate the reaction for 1-2 hours at room temperature or overnight at 4°C with gentle mixing.[6][8]
- (Optional) Quench the reaction by adding a quenching buffer to a final concentration of 50-100 mM and incubate for 15 minutes at room temperature.
- Remove the excess, unreacted **DBCO-PEG4-TFP ester** using a spin desalting column or through dialysis against an appropriate buffer.
- The DBCO-labeled protein is now ready for use in the SPAAC reaction or can be stored at 4°C for short-term use or -20°C for long-term storage.

Protocol 2: Metabolic Labeling of Live Cells with Ac4ManNAz

This protocol describes the introduction of azide groups onto the surface of live mammalian cells.

Materials:

- Mammalian cells of interest
- Complete cell culture medium
- Ac4ManNAz
- Anhydrous DMSO

Procedure:

- Culture cells to the desired confluency in a suitable culture vessel (e.g., 6-well plate, 96-well plate, or on coverslips for microscopy).

- Prepare a stock solution of Ac4ManNAz in anhydrous DMSO (e.g., 10 mM).
- Add the Ac4ManNAz stock solution to the cell culture medium to achieve a final concentration of 10–50 μM .^{[6][7]} It is recommended to test a range of concentrations to determine the optimal balance between labeling efficiency and cell viability for your specific cell line.^[6]
- Incubate the cells under their normal growth conditions (37°C, 5% CO₂) for 24–72 hours to allow for metabolic incorporation of the azide sugar into cell surface glycans.^{[4][5]}

Protocol 3: Live Cell Surface Labeling via SPAAC and Imaging

This protocol details the "click" reaction between the DBCO-labeled protein and azide-expressing cells, followed by imaging.

Materials:

- Ac4ManNAz-labeled live cells (from Protocol 2)
- DBCO-labeled protein (from Protocol 1) conjugated to a fluorophore
- Phosphate-Buffered Saline (PBS) or complete cell culture medium for washing
- Live-cell imaging medium
- Fluorescence microscope equipped for live-cell imaging

Procedure:

- After the metabolic labeling period, gently wash the cells 2-3 times with warm PBS or complete cell culture medium to remove any residual Ac4ManNAz.^[9]
- Dilute the DBCO-labeled fluorescent protein in fresh, pre-warmed cell culture medium to a final concentration of 10–20 μM .^[9]
- Add the DBCO-probe solution to the azide-labeled cells.

- Incubate the cells for 30-60 minutes at 37°C.[9][10]
- Gently wash the cells 2-3 times with warm PBS or cell culture medium to remove the unbound DBCO-probe.[9][11]
- Replace the wash buffer with a suitable live-cell imaging medium.
- Image the labeled cells using a fluorescence microscope with the appropriate filter sets for the chosen fluorophore.

Protocol 4: Assessment of Cell Viability (MTT Assay)

It is crucial to assess the potential cytotoxicity of the labeling procedure. The MTT assay is a colorimetric assay for assessing cell metabolic activity, which is an indicator of cell viability.

Materials:

- Cells cultured in a 96-well plate (with and without labeling)
- MTT (3-(4,5-dimethylthiazol-2-yl)-2,5-diphenyltetrazolium bromide) solution (5 mg/mL in PBS)
- Solubilization solution (e.g., DMSO or a solution of 10% SDS in 0.01 M HCl)
- Plate reader

Procedure:

- Following the complete labeling procedure (metabolic labeling and SPAAC), remove the medium from the cells.
- Add 100 μ L of fresh medium and 10 μ L of the MTT solution to each well.
- Incubate the plate for 2-4 hours at 37°C, allowing viable cells to reduce the yellow MTT to purple formazan crystals.
- Add 100 μ L of the solubilization solution to each well and mix thoroughly to dissolve the formazan crystals.

- Measure the absorbance at 570 nm using a plate reader.
- Compare the absorbance of the labeled cells to untreated control cells to determine the relative viability.

Visualizations

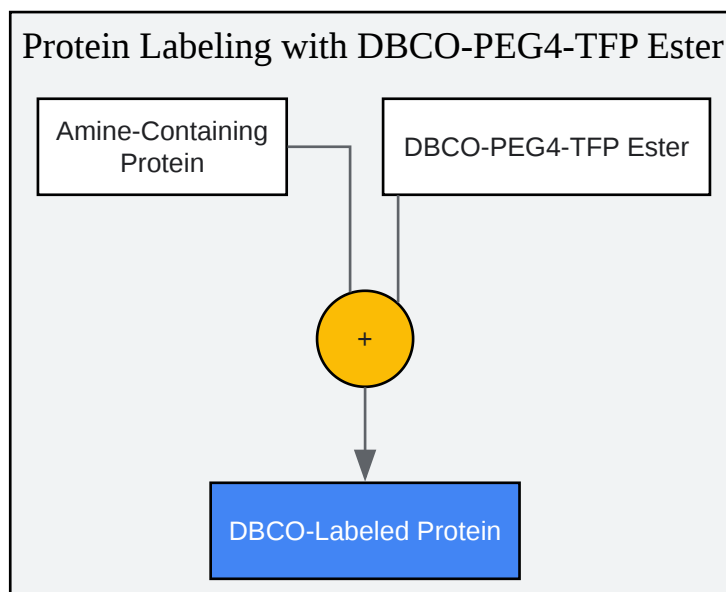

[Click to download full resolution via product page](#)

Caption: Workflow for labeling a protein with **DBCO-PEG4-TFP ester**.

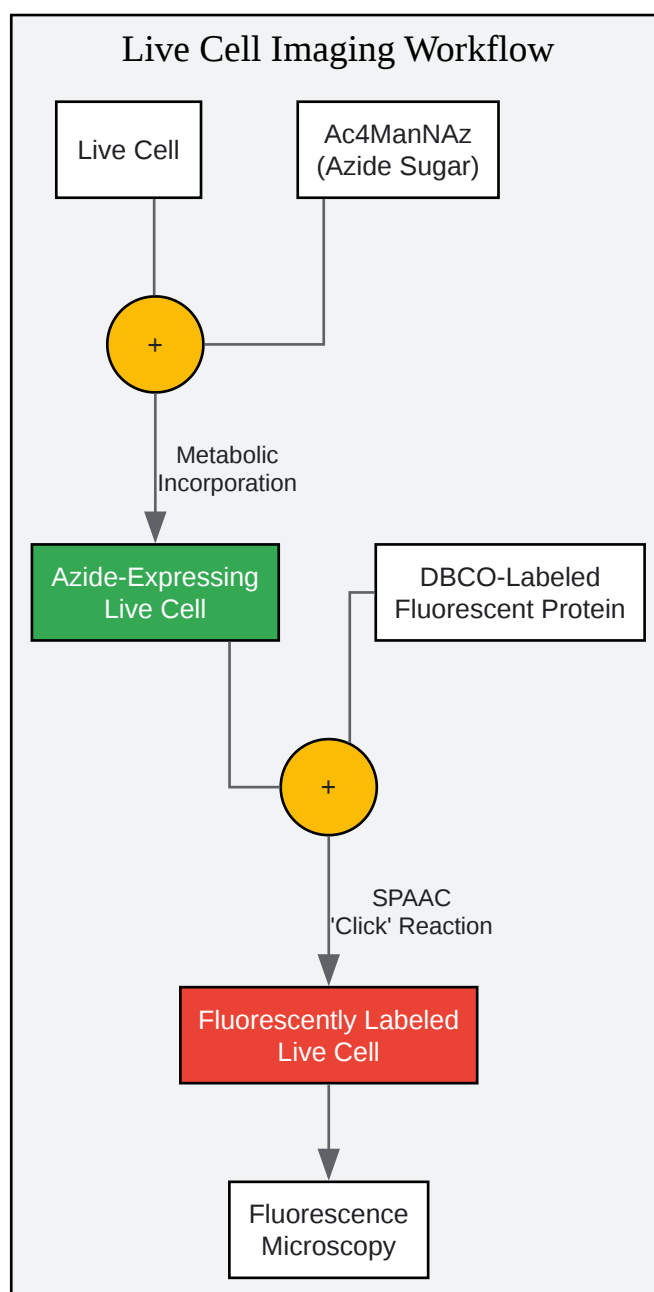

[Click to download full resolution via product page](#)

Caption: Two-step live cell imaging workflow.

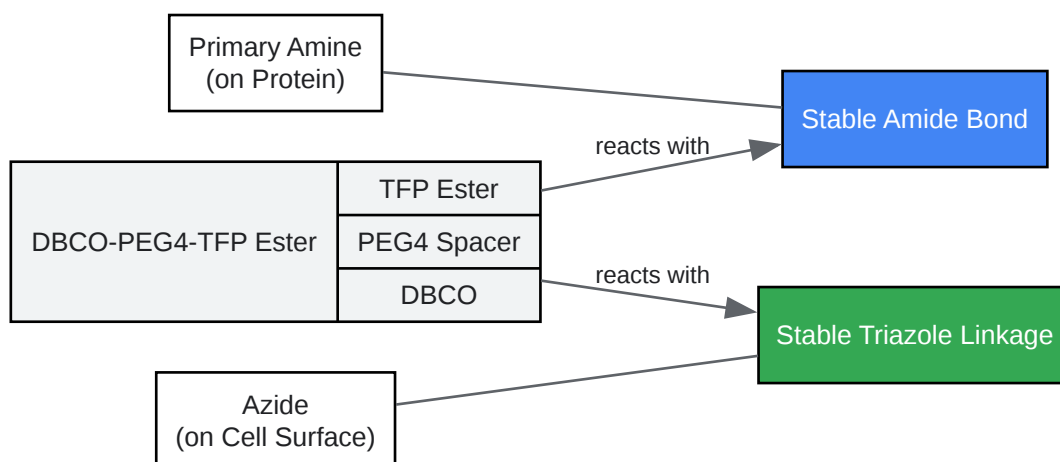

[Click to download full resolution via product page](#)

Caption: Key chemical reactions of **DBCO-PEG4-TFP ester**.

Need Custom Synthesis?

BenchChem offers custom synthesis for rare earth carbides and specific isotopic labeling.

Email: info@benchchem.com or [Request Quote Online](#).

References

- 1. [pnas.org](https://pubs.pnas.org) [[pnas.org](https://pubs.pnas.org)]
- 2. [vectorlabs.com](https://www.vectorlabs.com) [[vectorlabs.com](https://www.vectorlabs.com)]
- 3. [broadpharm.com](https://www.broadpharm.com) [[broadpharm.com](https://www.broadpharm.com)]
- 4. [researchgate.net](https://www.researchgate.net) [[researchgate.net](https://www.researchgate.net)]
- 5. pubs.acs.org [pubs.acs.org]
- 6. Physiological Effects of Ac4ManNAz and Optimization of Metabolic Labeling for Cell Tracking - PMC [[pmc.ncbi.nlm.nih.gov](https://pubmed.ncbi.nlm.nih.gov)]
- 7. [researchgate.net](https://www.researchgate.net) [[researchgate.net](https://www.researchgate.net)]
- 8. [thno.org](https://www.thno.org) [[thno.org](https://www.thno.org)]
- 9. prod-vector-labs-wordpress-media.s3.amazonaws.com:443 [prod-vector-labs-wordpress-media.s3.amazonaws.com:443]

- 10. Visualizing Metabolically-Labeled Glycoconjugates of Living Cells by Copper-Free and Fast Huisgen Cycloadditions - PMC [pmc.ncbi.nlm.nih.gov]
- 11. vectorlabs.com [vectorlabs.com]
- To cite this document: BenchChem. [Application Notes and Protocols: DBCO-PEG4-TFP Ester for Live Cell Imaging]. BenchChem, [2025]. [Online PDF]. Available at: [https://www.benchchem.com/product/b15290342#dbco-peg4-tfp-ester-for-live-cell-imaging-applications]

Disclaimer & Data Validity:

The information provided in this document is for Research Use Only (RUO) and is strictly not intended for diagnostic or therapeutic procedures. While BenchChem strives to provide accurate protocols, we make no warranties, express or implied, regarding the fitness of this product for every specific experimental setup.

Technical Support: The protocols provided are for reference purposes. Unsure if this reagent suits your experiment? [[Contact our Ph.D. Support Team for a compatibility check](#)]

Need Industrial/Bulk Grade? [Request Custom Synthesis Quote](#)

BenchChem

Our mission is to be the trusted global source of essential and advanced chemicals, empowering scientists and researchers to drive progress in science and industry.

Contact

Address: 3281 E Guasti Rd
Ontario, CA 91761, United States
Phone: (601) 213-4426
Email: info@benchchem.com