

# Application Notes and Protocols: ABC99

## Treatment in MCF-7 Cells

**Author:** BenchChem Technical Support Team. **Date:** December 2025

### Compound of Interest

Compound Name: ABC99

Cat. No.: B1192063

[Get Quote](#)

Audience: Researchers, scientists, and drug development professionals.

Introduction: **ABC99** is a novel, potent, and highly selective small molecule inhibitor of the Phosphoinositide 3-kinase (PI3K) signaling pathway. This pathway, particularly the PI3K/Akt/mTOR axis, is a critical regulator of cell proliferation, survival, and metabolism.[1][2][3] Dysregulation of this pathway is a common event in many cancers, including breast cancer, making it a key target for therapeutic intervention.[1][3] In hormone receptor-positive (HR+) breast cancer cell lines such as MCF-7, mutations in the PIK3CA gene, which encodes the p110 $\alpha$  catalytic subunit of PI3K, are frequently observed, leading to constitutive activation of the pathway.[3] These application notes provide detailed protocols for the treatment of MCF-7 cells with **ABC99** and for assessing its biological effects.

## Mechanism of Action

**ABC99** selectively inhibits the p110 $\alpha$  isoform of PI3K, leading to a downstream reduction in the phosphorylation and activation of Akt, a key signaling node. This inhibition ultimately results in decreased cell viability and the induction of apoptosis in cancer cells with a constitutively active PI3K/Akt/mTOR pathway.

## Quantitative Data Summary

The following tables summarize the quantitative data for the effects of **ABC99** on MCF-7 cells.

Table 1: Cell Viability (IC<sub>50</sub>) of **ABC99** on MCF-7 Cells

Treatment Duration	IC50 (nM)	Assay Method
24 hours	150	MTT Assay
48 hours	75	MTT Assay
72 hours	40	MTT Assay

 Table 2: Apoptosis Induction by **ABC99** in MCF-7 Cells (24-hour treatment)

ABC99 Concentration (nM)	Early Apoptotic Cells (%)	Late Apoptotic Cells (%)	Total Apoptotic Cells (%)
0 (Control)	2.1	1.5	3.6
50	10.3	4.2	14.5
100	25.6	12.8	38.4
200	40.1	22.5	62.6

 Table 3: Inhibition of Akt Phosphorylation by **ABC99** in MCF-7 Cells (6-hour treatment)

ABC99 Concentration (nM)	Relative p-Akt (Ser473) Level (%)
0 (Control)	100
10	78
50	45
100	15
250	<5

## Experimental Protocols

### MCF-7 Cell Culture

- Media: Dulbecco's Modified Eagle's Medium (DMEM) supplemented with 10% Fetal Bovine Serum (FBS), 100 U/mL penicillin, and 100 µg/mL streptomycin.[4]

- Culture Conditions: Incubate cells at 37°C in a humidified atmosphere with 5% CO<sub>2</sub>.
- Passaging: When cells reach 80-90% confluency, aspirate the medium, wash with PBS, and detach using Trypsin-EDTA. Resuspend the cells in fresh medium and re-plate at the desired density.

## Cell Viability (MTT) Assay

This protocol is used to determine the concentration of **ABC99** that inhibits cell growth by 50% (IC<sub>50</sub>).

- Procedure:
  - Seed MCF-7 cells in a 96-well plate at a density of  $1 \times 10^4$  cells/well and allow them to adhere overnight.[5]
  - Prepare serial dilutions of **ABC99** in culture medium.
  - Remove the old medium and add 100 µL of the medium containing different concentrations of **ABC99** to the wells. Include a vehicle control (e.g., DMSO).
  - Incubate the plate for 24, 48, or 72 hours.[5]
  - Add 10 µL of MTT solution (5 mg/mL in PBS) to each well and incubate for 4 hours at 37°C.[5]
  - Aspirate the medium and add 100 µL of DMSO to each well to dissolve the formazan crystals.[4]
  - Measure the absorbance at 570 nm using a microplate reader.
  - Calculate cell viability as a percentage of the vehicle-treated control and determine the IC<sub>50</sub> value.[6]

## Western Blotting for p-Akt

This protocol is used to assess the inhibition of Akt phosphorylation by **ABC99**.

- Procedure:
  - Seed MCF-7 cells in a 6-well plate and grow to 70-80% confluency.
  - Treat the cells with various concentrations of **ABC99** for the desired time (e.g., 6 hours).
  - Wash the cells with ice-cold PBS and lyse them in RIPA buffer containing protease and phosphatase inhibitors.
  - Determine the protein concentration of the lysates using a BCA assay.
  - Denature 20-30 µg of protein per sample by boiling in SDS-PAGE sample buffer.[7]
  - Separate the proteins by SDS-PAGE and transfer them to a PVDF membrane.[8]
  - Block the membrane with 5% BSA in TBST for 1 hour at room temperature.[9][10]
  - Incubate the membrane with a primary antibody against phospho-Akt (Ser473) overnight at 4°C.[7][8]
  - Wash the membrane with TBST and incubate with an HRP-conjugated secondary antibody for 1 hour at room temperature.
  - Detect the signal using an ECL detection reagent.
  - Strip the membrane and re-probe for total Akt and a loading control (e.g., GAPDH or β-actin) for normalization.

## Apoptosis Assay (Annexin V-FITC/PI Staining)

This protocol quantifies the percentage of apoptotic and necrotic cells following **ABC99** treatment.

- Procedure:
  - Seed MCF-7 cells in a 6-well plate and treat with different concentrations of **ABC99** for 24 hours.
  - Collect both the floating and adherent cells.[11]

- Wash the cells twice with cold PBS.
- Resuspend the cells in 1X Binding Buffer at a concentration of  $1 \times 10^6$  cells/mL.
- Add 5  $\mu$ L of Annexin V-FITC and 5  $\mu$ L of Propidium Iodide (PI) to 100  $\mu$ L of the cell suspension.[\[5\]](#)
- Incubate the cells for 15 minutes at room temperature in the dark.
- Add 400  $\mu$ L of 1X Binding Buffer to each tube.
- Analyze the cells by flow cytometry within 1 hour.[\[5\]](#)[\[11\]](#)[\[12\]](#)

## Visualizations

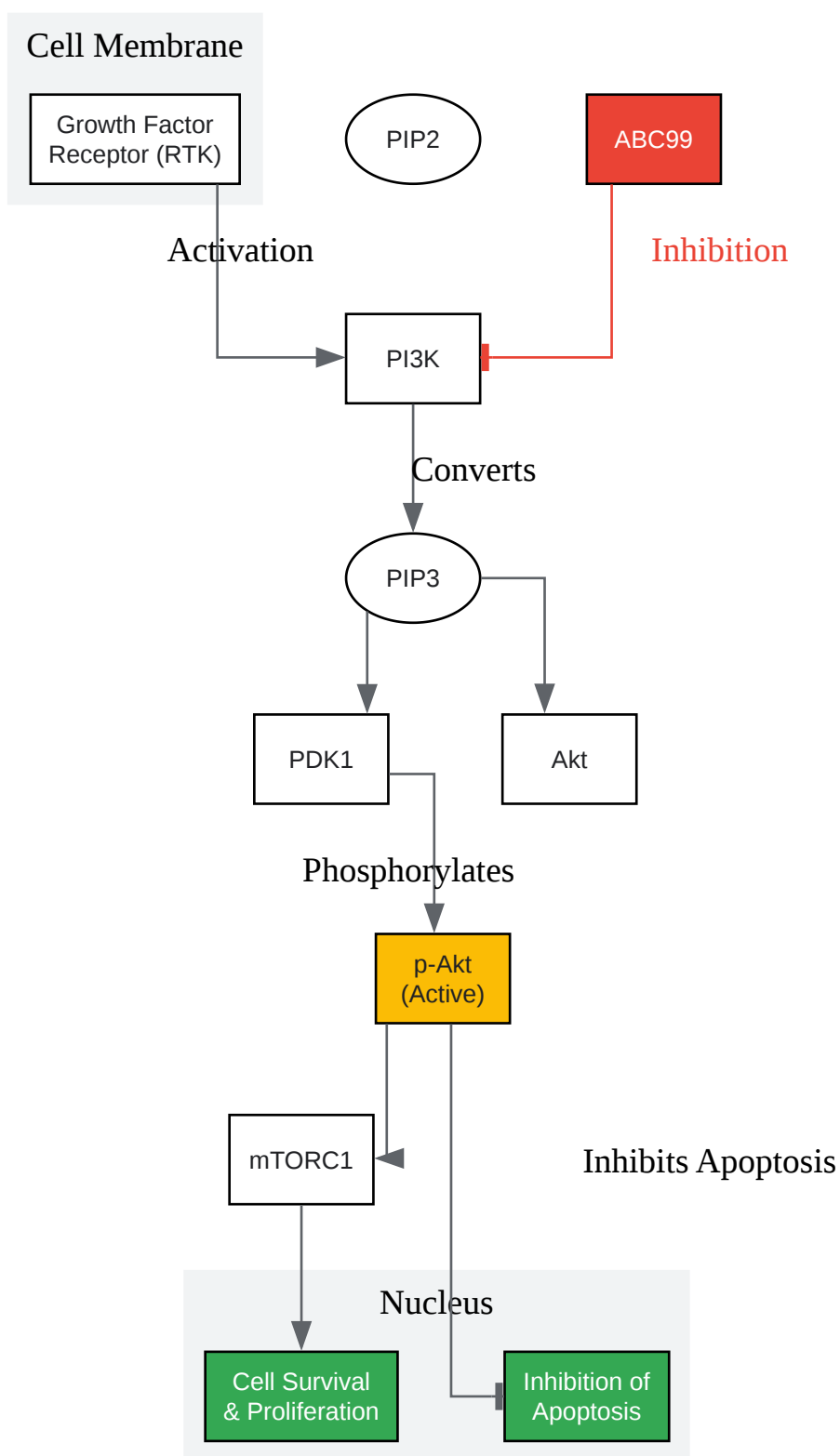

[Click to download full resolution via product page](#)

Caption: **ABC99** inhibits the PI3K/Akt/mTOR signaling pathway.

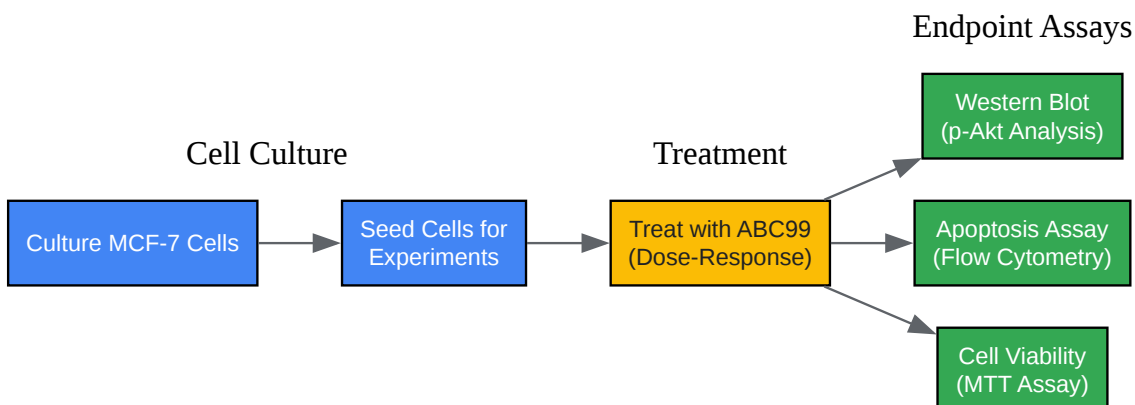

[Click to download full resolution via product page](#)

Caption: Experimental workflow for assessing **ABC99** efficacy.

### Need Custom Synthesis?

BenchChem offers custom synthesis for rare earth carbides and specific isotopic labeling.

Email: [info@benchchem.com](mailto:info@benchchem.com) or [Request Quote Online](#).

## References

- 1. [m.youtube.com](https://m.youtube.com) [[m.youtube.com](https://m.youtube.com)]
- 2. [youtube.com](https://youtube.com) [[youtube.com](https://youtube.com)]
- 3. [jscimedcentral.com](https://jscimedcentral.com) [[jscimedcentral.com](https://jscimedcentral.com)]
- 4. [japsonline.com](https://japsonline.com) [[japsonline.com](https://japsonline.com)]
- 5. Induction of Apoptosis in Human Breast Cancer MCF-7 Cells by a Semi-Synthetic Derivative of Artemisinin: A Caspase-Related Mechanism - PMC [[pmc.ncbi.nlm.nih.gov](https://pubmed.ncbi.nlm.nih.gov)]
- 6. A Comparative Study on Viability of MCF-7 Human Breast Cancer Cell Lines Using Piperine and Tamoxifen – An In Vitro Study with A Novel Mishmash – Biomedical and Pharmacology Journal [[biomedpharmajournal.org](https://biomedpharmajournal.org)]
- 7. [ccrod.cancer.gov](https://ccrod.cancer.gov) [[ccrod.cancer.gov](https://ccrod.cancer.gov)]

- 8. Quantitative analysis of Akt phosphorylation and activity in response to EGF and insulin treatment - PMC [pmc.ncbi.nlm.nih.gov]
- 9. Western blot for phosphorylated proteins | Abcam [abcam.com]
- 10. bio-rad-antibodies.com [bio-rad-antibodies.com]
- 11. Protocol for Apoptosis Assay by Flow Cytometry Using Annexin V Staining Method [bio-protocol.org]
- 12. researchgate.net [researchgate.net]
- To cite this document: BenchChem. [Application Notes and Protocols: ABC99 Treatment in MCF-7 Cells]. BenchChem, [2025]. [Online PDF]. Available at: [https://www.benchchem.com/product/b1192063#protocol-for-abc99-treatment-in-specific-cell-line]

---

#### Disclaimer & Data Validity:

The information provided in this document is for Research Use Only (RUO) and is strictly not intended for diagnostic or therapeutic procedures. While BenchChem strives to provide accurate protocols, we make no warranties, express or implied, regarding the fitness of this product for every specific experimental setup.

**Technical Support:** The protocols provided are for reference purposes. Unsure if this reagent suits your experiment? [[Contact our Ph.D. Support Team for a compatibility check](#)]

**Need Industrial/Bulk Grade?** [Request Custom Synthesis Quote](#)

## BenchChem

Our mission is to be the trusted global source of essential and advanced chemicals, empowering scientists and researchers to drive progress in science and industry.

#### Contact

Address: 3281 E Guasti Rd  
Ontario, CA 91761, United States  
Phone: (601) 213-4426  
Email: [info@benchchem.com](mailto:info@benchchem.com)