

# Application Notes: Targeted Degradation of BRD4 using a Thalidomide-Based PROTAC

**Author:** BenchChem Technical Support Team. **Date:** December 2025

## Compound of Interest

Compound Name: *Thalidomide-NH-C5-NH2 hydrochloride*

Cat. No.: *B2608549*

[Get Quote](#)

For research use only. Not for use in diagnostic procedures.

## Introduction

Proteolysis-targeting chimeras (PROTACs) are a novel therapeutic modality designed to eliminate specific proteins from the cell by hijacking the ubiquitin-proteasome system.[1] These heterobifunctional molecules consist of a ligand that binds to a target protein of interest (POI), another ligand that recruits an E3 ubiquitin ligase, and a linker connecting them.[1][2] This document provides detailed information and protocols for a PROTAC that utilizes a thalidomide-based moiety, such as **Thalidomide-NH-C5-NH2 hydrochloride**, to recruit the Cereblon (CRBN) E3 ubiquitin ligase for the targeted degradation of Bromodomain-containing protein 4 (BRD4).[1][3][4]

BRD4 is a key epigenetic reader in the Bromodomain and Extra-Terminal domain (BET) family, which plays a critical role in regulating the transcription of oncogenes like c-Myc.[3] By inducing the degradation of BRD4 rather than just inhibiting it, PROTACs can offer a more potent and sustained therapeutic effect, making them a powerful tool for cancer research and drug development.[5]

## Principle of Action

The PROTAC acts as a molecular bridge, inducing proximity between BRD4 and the CRBN E3 ligase complex.[5] This leads to the formation of a ternary complex (BRD4-PROTAC-CRBN),

which facilitates the transfer of ubiquitin from an E2 conjugating enzyme to lysine residues on the BRD4 protein.[4] The resulting polyubiquitin chain acts as a recognition signal for the 26S proteasome, which then degrades the BRD4 protein into small peptides.[6] The PROTAC molecule is then released and can act catalytically to induce the degradation of another BRD4 protein.[6]

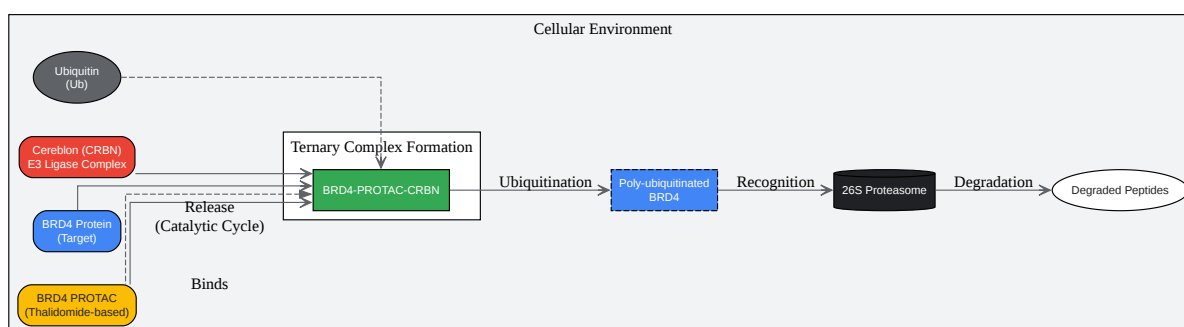

[Click to download full resolution via product page](#)

**Figure 1.** Mechanism of PROTAC-mediated BRD4 degradation.

## Quantitative Data Summary

The efficacy of a BRD4-targeting PROTAC is primarily assessed by its ability to induce protein degradation (DC50) and inhibit cell growth (GI50/IC50). Below is a summary of representative data for well-characterized, thalidomide-based BRD4 degraders like ARV-825 and dBET1.

Compound	Target Protein	E3 Ligase Recruited	Cell Line	DC50 (nM)	GI50/IC50 (nM)	Reference
ARV-825	BRD4	Cereblon (CRBN)	Jurkat (T-ALL)	< 1	-	[7]
ARV-825	BRD4	Cereblon (CRBN)	T-ALL Cell Lines	-	Lower than JQ1/dBET 1	[8][9]
dBET1	BRD4	Cereblon (CRBN)	Various Cancer Lines	Varies	-	[10]
QCA570	BRD4	Varies	Bladder Cancer Cells	~1	-	[11]

Note: DC50 (Degradation Concentration 50) is the concentration of the compound that results in 50% degradation of the target protein. GI50/IC50 (Growth Inhibition/Inhibitory Concentration 50) is the concentration that causes 50% inhibition of cell proliferation.

## Experimental Protocols

The following protocols provide a framework for evaluating the efficacy of a thalidomide-based BRD4 degrader in a laboratory setting.

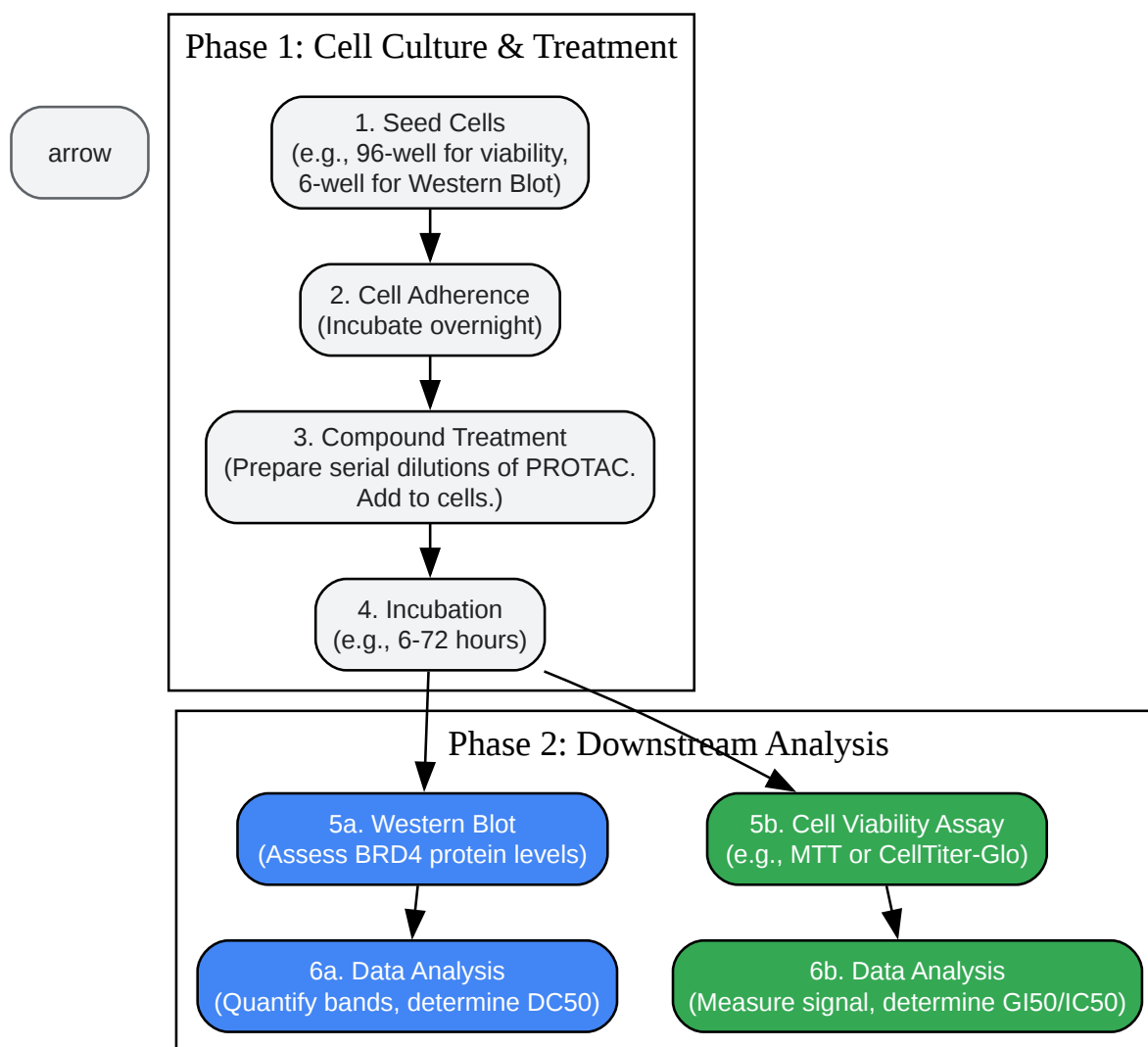

[Click to download full resolution via product page](#)

**Figure 2.** General experimental workflow for PROTAC evaluation.

## Protocol 1: Western Blot for BRD4 Degradation

This protocol is used to quantify the reduction in cellular BRD4 protein levels following PROTAC treatment.[7][12]

Materials:

- Cell culture reagents and appropriate cancer cell line (e.g., TPC-1, Jurkat).[8][13]

- BRD4-targeting PROTAC.
- Vehicle control (e.g., DMSO).
- RIPA lysis buffer with protease and phosphatase inhibitors.[14]
- BCA Protein Assay Kit.
- SDS-PAGE equipment and reagents (e.g., 4-15% gel).[12]
- PVDF membrane.[12]
- Blocking buffer (5% non-fat milk or BSA in TBST).[14]
- Primary antibodies: anti-BRD4, anti-c-Myc, and a loading control (e.g., anti- $\beta$ -actin or anti-GAPDH).[15]
- HRP-conjugated secondary antibody.[12]
- Chemiluminescent substrate (ECL).[4]

#### Procedure:

- Cell Seeding & Treatment: Seed cells in 6-well plates and allow them to attach overnight. Treat cells with a serial dilution of the PROTAC (e.g., 0.1 nM to 10  $\mu$ M) for a predetermined time (e.g., 6, 18, or 24 hours).[16] Include a vehicle-only control.
- Cell Lysis: Wash cells with ice-cold PBS. Add 100-200  $\mu$ L of ice-cold RIPA buffer to each well, scrape the cells, and transfer the lysate to a microcentrifuge tube.[14][17]
- Lysate Preparation: Incubate the lysate on ice for 30 minutes, then centrifuge at 14,000 x g for 15 minutes at 4°C.[14] Collect the supernatant.
- Protein Quantification: Determine the protein concentration of each sample using a BCA assay.[14]
- Sample Preparation & SDS-PAGE: Normalize all samples to the same protein concentration. Add Laemmli sample buffer and boil at 95°C for 5 minutes. Load 20-30  $\mu$ g of protein per lane

onto an SDS-PAGE gel.[12][17]

- Protein Transfer: Transfer the separated proteins to a PVDF membrane.[12]
- Immunoblotting:
  - Block the membrane with blocking buffer for 1 hour at room temperature.[12]
  - Incubate the membrane with primary anti-BRD4 antibody (and anti-c-Myc, if desired) overnight at 4°C.[14]
  - Wash the membrane 3 times with TBST.
  - Incubate with HRP-conjugated secondary antibody for 1 hour at room temperature.[12]
  - Wash the membrane 3 times with TBST.
- Detection & Analysis: Apply ECL substrate and visualize the bands using an imaging system. Quantify the band intensities and normalize the BRD4 signal to the loading control. Calculate the percentage of degradation relative to the vehicle control to determine the DC50 value.[4][6]

## Protocol 2: Cell Viability Assay (MTT or CellTiter-Glo®)

This protocol assesses the effect of BRD4 degradation on cell proliferation and viability.[18][19]

Materials:

- 96-well plates.
- BRD4-targeting PROTAC.
- Vehicle control (e.g., DMSO).
- MTT reagent and solubilization solution OR CellTiter-Glo® Luminescent Cell Viability Assay kit.

Procedure:

- Cell Seeding: Seed cells in a 96-well plate at an appropriate density and allow them to attach overnight.[18]
- Compound Treatment: Prepare serial dilutions of the PROTAC in complete culture medium. Add 100  $\mu$ L of the diluted compound or vehicle control to the wells.
- Incubation: Incubate the plate for the desired treatment period (e.g., 72 hours).[4]
- Assay Procedure (CellTiter-Glo® Example):
  - Equilibrate the plate and CellTiter-Glo® reagent to room temperature.[18]
  - Add 100  $\mu$ L of CellTiter-Glo® reagent to each well.[18]
  - Mix on an orbital shaker for 2 minutes to induce cell lysis.
  - Incubate at room temperature for 10 minutes to stabilize the luminescent signal.[18]
- Data Acquisition & Analysis: Measure luminescence using a plate reader. Subtract the average background signal from all readings. Calculate the percentage of cell viability for each treatment relative to the vehicle control. Plot the percentage of viability against the log of the compound concentration to determine the GI50 or IC50 value.[18]

## Troubleshooting

- No/Poor Degradation:
  - Suboptimal Concentration: Perform a wider dose-response curve. Very high concentrations can cause the "hook effect," where degradation efficiency decreases.[5]
  - Incorrect Incubation Time: Conduct a time-course experiment (e.g., 2, 6, 12, 24 hours) as degradation kinetics can be rapid.[5]
  - Low E3 Ligase Expression: Confirm the expression of Cereblon (CRBN) in your cell line via Western Blot.[5]
  - Proteasome Inhibition: Ensure proteasome function is not compromised. Co-treat with a proteasome inhibitor (e.g., MG-132) as a negative control; this should rescue BRD4 from

degradation.[11]

- High Variability in Viability Assay:
  - Inconsistent Seeding: Ensure a homogenous single-cell suspension before seeding.
  - Edge Effects: Avoid using the outer wells of the 96-well plate or fill them with sterile PBS.
  - Compound Precipitation: Check the solubility of the PROTAC in the culture medium.

#### **Need Custom Synthesis?**

*BenchChem offers custom synthesis for rare earth carbides and specific isotopic labeling.*

*Email: [info@benchchem.com](mailto:info@benchchem.com) or [Request Quote Online](#).*

## References

- 1. Frontiers | E3 Ligase Ligands in Successful PROTACs: An Overview of Syntheses and Linker Attachment Points [frontiersin.org]
- 2. researchgate.net [researchgate.net]
- 3. benchchem.com [benchchem.com]
- 4. benchchem.com [benchchem.com]
- 5. benchchem.com [benchchem.com]
- 6. benchchem.com [benchchem.com]
- 7. benchchem.com [benchchem.com]
- 8. BRD4 PROTAC degrader ARV-825 inhibits T-cell acute lymphoblastic leukemia by targeting 'Undruggable' Myc-pathway genes - PMC [pmc.ncbi.nlm.nih.gov]
- 9. BRD4 PROTAC degrader ARV-825 inhibits T-cell acute lymphoblastic leukemia by targeting 'Undruggable' Myc-pathway genes - PubMed [pubmed.ncbi.nlm.nih.gov]
- 10. researchgate.net [researchgate.net]
- 11. Frontiers | Lethal activity of BRD4 PROTAC degrader QCA570 against bladder cancer cells [frontiersin.org]
- 12. benchchem.com [benchchem.com]



- 13. ARV-825-induced BRD4 protein degradation as a therapy for thyroid carcinoma | Aging [aging-us.com]
- 14. benchchem.com [benchchem.com]
- 15. BRD4 Antibody | Cell Signaling Technology [cellsignal.com]
- 16. benchchem.com [benchchem.com]
- 17. bio-rad.com [bio-rad.com]
- 18. benchchem.com [benchchem.com]
- 19. benchchem.com [benchchem.com]
- To cite this document: BenchChem. [Application Notes: Targeted Degradation of BRD4 using a Thalidomide-Based PROTAC]. BenchChem, [2025]. [Online PDF]. Available at: [https://www.benchchem.com/product/b2608549#thalidomide-nh-c5-nh2-hydrochloride-for-brd4-degradation]

---

#### Disclaimer & Data Validity:

The information provided in this document is for Research Use Only (RUO) and is strictly not intended for diagnostic or therapeutic procedures. While BenchChem strives to provide accurate protocols, we make no warranties, express or implied, regarding the fitness of this product for every specific experimental setup.

**Technical Support:** The protocols provided are for reference purposes. Unsure if this reagent suits your experiment? [[Contact our Ph.D. Support Team for a compatibility check](#)]

**Need Industrial/Bulk Grade?** [Request Custom Synthesis Quote](#)

## BenchChem

Our mission is to be the trusted global source of essential and advanced chemicals, empowering scientists and researchers to drive progress in science and industry.

#### Contact

Address: 3281 E Guasti Rd

Ontario, CA 91761, United States

Phone: (601) 213-4426

Email: [info@benchchem.com](mailto:info@benchchem.com)