

Application Notes & Protocols for Quantitative Western Blot Analysis of CP26 Abundance

Author: BenchChem Technical Support Team. **Date:** December 2025

Compound of Interest

Compound Name: CP26

Cat. No.: B15578014

[Get Quote](#)

Audience: Researchers, scientists, and drug development professionals.

Introduction

The Chlorophyll a/b-binding protein **CP26**, also known as Lhcb5, is a minor antenna protein component of the Photosystem II (PSII) in plants and algae.^{[1][2][3]} It plays a crucial role in light harvesting and in the protective dissipation of excess light energy, a process known as non-photochemical quenching (NPQ).^{[1][4][5][6]} The abundance of **CP26** can be indicative of the photosynthetic efficiency and stress response of the organism.^{[1][3][7]} Therefore, accurate quantification of **CP26** abundance is critical for studies in plant physiology, photosynthesis research, and for assessing the impact of environmental stressors or chemical compounds on plant health. This document provides a detailed protocol for the quantitative Western blot analysis of **CP26**.

Experimental Protocols

A successful quantitative Western blot requires careful sample preparation, meticulous execution of the blotting procedure, and rigorous data analysis.^{[8][9][10]}

Sample Preparation: Thylakoid Membrane Isolation

Since **CP26** is an integral membrane protein located in the thylakoid membranes of chloroplasts, isolating these membranes is crucial for enriching the protein of interest.^[11]

Materials:

- Plant tissue (e.g., *Arabidopsis thaliana* leaves)
- Grinding Buffer (50 mM HEPES-KOH pH 7.5, 330 mM sorbitol, 10 mM NaCl, 5 mM MgCl₂, 2 mM EDTA)
- Wash Buffer (50 mM HEPES-KOH pH 7.5, 330 mM sorbitol, 2.5 mM EDTA)
- Resuspension Buffer (20 mM HEPES-KOH pH 7.5, 100 mM sorbitol, 15 mM NaCl)
- Protease inhibitor cocktail
- Ice-cold mortar and pestle or blender
- Cheesecloth and Miracloth
- Refrigerated centrifuge

Protocol:

- Harvest fresh plant tissue and perform all subsequent steps at 4°C or on ice to minimize protein degradation.[8]
- Add protease inhibitor cocktail to all buffers immediately before use.
- Homogenize the tissue in ice-cold Grinding Buffer.
- Filter the homogenate through several layers of cheesecloth and Miracloth to remove large debris.
- Centrifuge the filtrate at 4,000 x g for 10 minutes at 4°C to pellet the chloroplasts.
- Gently resuspend the chloroplast pellet in Wash Buffer.
- Centrifuge at 4,000 x g for 10 minutes at 4°C. Discard the supernatant.
- Lyse the chloroplasts by resuspending the pellet in hypotonic Resuspension Buffer.
- Incubate on ice for 30 minutes.

- Centrifuge at 12,000 x g for 20 minutes at 4°C to pellet the thylakoid membranes.
- Discard the supernatant and resuspend the thylakoid pellet in a minimal volume of Resuspension Buffer with protease inhibitors.
- Determine the protein concentration using a detergent-compatible protein assay (e.g., BCA assay).

SDS-PAGE and Western Blotting

Materials:

- Thylakoid membrane samples
- Laemmli sample buffer (2x)
- SDS-polyacrylamide gels (12% resolving gel is suitable for **CP26**, which has an apparent molecular weight of 25-26 kDa).[2]
- Electrophoresis running buffer
- PVDF or nitrocellulose membranes
- Transfer buffer
- Blocking buffer (e.g., 5% non-fat dry milk or 3% BSA in TBS-T)
- Primary antibody: Anti-Lhcb5/**CP26** (e.g., Agrisera AS01 009)
- HRP-conjugated secondary antibody
- Chemiluminescent substrate
- Imaging system (e.g., CCD camera-based imager)

Protocol:

- Dilute thylakoid samples to the desired concentration in Resuspension Buffer and mix with an equal volume of 2x Laemmli sample buffer.

- To avoid aggregation of membrane proteins, do not boil the samples. Instead, incubate at 75°C for 5 minutes.[2]
- Load equal amounts of total protein (typically 10-30 µg) per lane of the SDS-PAGE gel.[12] It is crucial to first determine the linear range of detection for your specific antibody and sample type.[9][10]
- Run the gel until adequate separation is achieved.
- Transfer the separated proteins to a PVDF membrane. Confirm transfer efficiency using Ponceau S staining.
- Block the membrane for 1 hour at room temperature in blocking buffer to prevent non-specific antibody binding.
- Incubate the membrane with the primary anti-**CP26** antibody (e.g., at a 1:1000 dilution in blocking buffer) overnight at 4°C with gentle agitation.[2]
- Wash the membrane three times for 10 minutes each with TBS-T.
- Incubate with the HRP-conjugated secondary antibody (e.g., at a 1:20,000 dilution in blocking buffer) for 1 hour at room temperature.[2]
- Wash the membrane again as in step 8.
- Prepare the chemiluminescent substrate according to the manufacturer's instructions and apply it to the membrane.
- Capture the signal using a digital imaging system. Avoid using film, as it has a limited linear range and is prone to saturation.[9]

Data Acquisition and Quantitative Analysis

Protocol:

- Image Acquisition: Capture a series of images with increasing exposure times to ensure that the signal for all bands of interest is within the linear dynamic range of the camera (i.e., not saturated).

- Densitometry: Use image analysis software to measure the intensity of the bands corresponding to **CP26**.[\[13\]](#)
- Background Subtraction: Apply a consistent background subtraction method to all lanes and blots.[\[13\]](#)
- Normalization: To correct for variations in sample loading and transfer, normalize the **CP26** band intensity. Total protein normalization (TPN) is often more accurate than using housekeeping proteins, whose expression may vary under different conditions.[\[12\]](#)[\[13\]](#)[\[14\]](#) TPN can be achieved by staining the membrane with a total protein stain (e.g., Ponceau S, SYPRO Ruby, or a stain-free technology) and quantifying the total protein in each lane.[\[12\]](#)
[\[13\]](#)
 - Normalization Calculation: Normalized **CP26** Abundance = (Intensity of **CP26** Band) / (Intensity of Total Protein in the Lane)
- Relative Quantification: Express the normalized **CP26** abundance in experimental samples relative to a control sample.[\[15\]](#)
 - Fold Change Calculation: Fold Change = (Normalized **CP26** in Experimental Sample) / (Normalized **CP26** in Control Sample)

Data Presentation

Quantitative data should be summarized in tables to facilitate comparison between different conditions or genotypes. For robust conclusions, experiments should be performed with at least three biological replicates.[\[9\]](#)[\[15\]](#)

Table 1: Quantitative Analysis of **CP26** Abundance in Wild-Type vs. **cp26**-Mutant Plants

Sample ID	Biological Replicate	CP26 Band Intensity (Arbitrary Units)	Total Protein Intensity (Arbitrary Units)	Normalized CP26 Abundance	Fold Change vs. Wild-Type
Wild-Type	1	15,234	25,100	0.607	1.00
Wild-Type	2	16,102	26,540	0.607	1.00
Wild-Type	3	14,880	24,750	0.601	0.99
cp26 Mutant	1	150	25,500	0.006	0.01
cp26 Mutant	2	180	26,100	0.007	0.01
cp26 Mutant	3	165	25,800	0.006	0.01

Table 2: Effect of High-Light Stress on **CP26** Abundance

Treatment	Biological Replicate	Normalized CP26 Abundance (Mean \pm SD)	p-value
Control Light	1, 2, 3	0.605 \pm 0.003	<0.05
High Light (4h)	1, 2, 3	0.750 \pm 0.025	

Visualizations

Diagrams

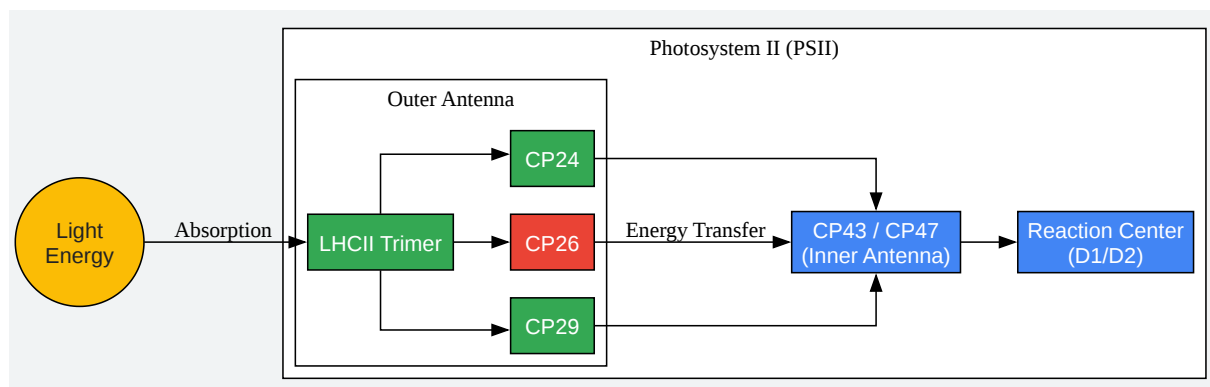

[Click to download full resolution via product page](#)

Caption: Role of **CP26** within the Photosystem II light-harvesting antenna complex.

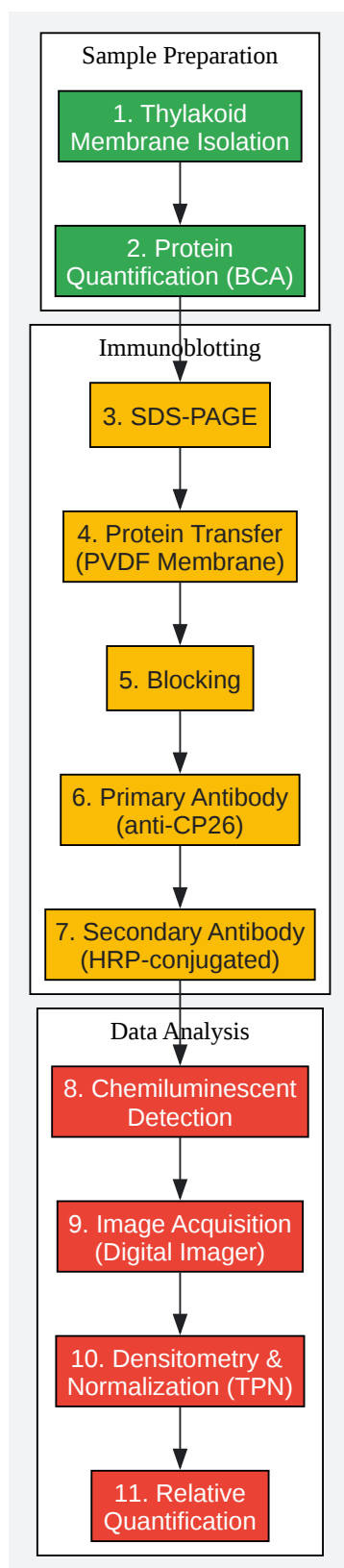

[Click to download full resolution via product page](#)

Caption: Workflow for quantitative Western blot analysis of **CP26**.

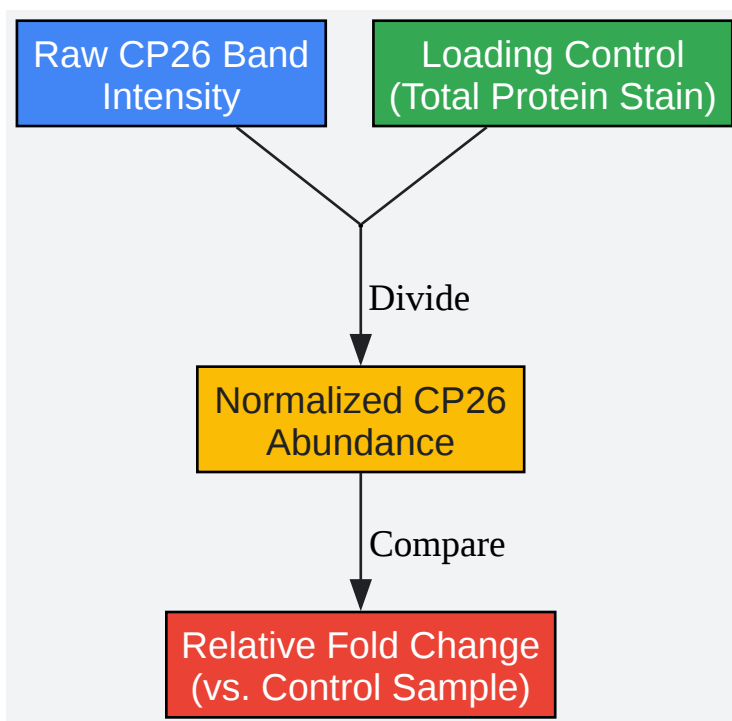

[Click to download full resolution via product page](#)

Caption: Logic diagram for total protein normalization in quantitative Western blotting.

Need Custom Synthesis?

BenchChem offers custom synthesis for rare earth carbides and specific isotopic labeling.

Email: info@benchchem.com or [Request Quote Online](#).

References

- 1. Minor Antenna Proteins CP24 and CP26 Affect the Interactions between Photosystem II Subunits and the Electron Transport Rate in Grana Membranes of Arabidopsis - PMC [pmc.ncbi.nlm.nih.gov]
- 2. agrisera.com [agrisera.com]
- 3. Light-harvesting chlorophyll a/b-binding proteins, positively involved in abscisic acid signalling, require a transcription repressor, WRKY40, to balance their function - PMC [pmc.ncbi.nlm.nih.gov]
- 4. Photosystem II antenna complexes CP26 and CP29 are essential for nonphotochemical quenching in Chlamydomonas reinhardtii - PubMed [pubmed.ncbi.nlm.nih.gov]

- 5. Photosystem II antenna complexes CP26 and CP29 are essential for nonphotochemical quenching in *Chlamydomonas reinhardtii* - PMC [pmc.ncbi.nlm.nih.gov]
- 6. Photosystem II monomeric antenna CP26 plays a key role in nonphotochemical quenching in *Chlamydomonas* - PubMed [pubmed.ncbi.nlm.nih.gov]
- 7. Identification of the Light-Harvesting Chlorophyll a/b Binding Protein Gene Family in Peach (*Prunus persica* L.) and Their Expression under Drought Stress - PMC [pmc.ncbi.nlm.nih.gov]
- 8. goldbio.com [goldbio.com]
- 9. bitesizebio.com [bitesizebio.com]
- 10. azurebiosystems.com [azurebiosystems.com]
- 11. biocompare.com [biocompare.com]
- 12. Quantitative Western Blot Analysis | Thermo Fisher Scientific - SG [thermofisher.com]
- 13. bio-rad.com [bio-rad.com]
- 14. Protein Quantification Using the "Rapid Western Blot" Approach - PubMed [pubmed.ncbi.nlm.nih.gov]
- 15. protocols.io [protocols.io]
- To cite this document: BenchChem. [Application Notes & Protocols for Quantitative Western Blot Analysis of CP26 Abundance]. BenchChem, [2025]. [Online PDF]. Available at: [https://www.benchchem.com/product/b15578014#quantitative-western-blot-analysis-of-cp26-abundance]

Disclaimer & Data Validity:

The information provided in this document is for Research Use Only (RUO) and is strictly not intended for diagnostic or therapeutic procedures. While BenchChem strives to provide accurate protocols, we make no warranties, express or implied, regarding the fitness of this product for every specific experimental setup.

Technical Support: The protocols provided are for reference purposes. Unsure if this reagent suits your experiment? [[Contact our Ph.D. Support Team for a compatibility check](#)]

Need Industrial/Bulk Grade? [Request Custom Synthesis Quote](#)

BenchChem

Our mission is to be the trusted global source of essential and advanced chemicals, empowering scientists and researchers to drive progress in science and industry.

Contact

Address: 3281 E Guasti Rd

Ontario, CA 91761, United States

Phone: (601) 213-4426

Email: info@benchchem.com