

# Application Notes & Protocols for Measuring Iguana-1 Activity

**Author:** BenchChem Technical Support Team. **Date:** December 2025

## Compound of Interest

Compound Name: *Iguana-1*

Cat. No.: *B10854943*

[Get Quote](#)

## Introduction

**Iguana-1** is a novel receptor tyrosine kinase (RTK) that has been identified as a critical mediator of cell proliferation and survival in various cancer models. Upon binding its cognate ligand, **Iguana-1** undergoes dimerization and autophosphorylation on key tyrosine residues within its intracellular domain. This phosphorylation cascade initiates a downstream signaling network, primarily through the IGU-MAPK pathway, making the quantification of its activity a crucial aspect of targeted drug development and cancer research.

These application notes provide detailed protocols for several robust methods to measure the activation and activity of **Iguana-1**, tailored for researchers in academic and industrial settings.

## Application Note 1: Quantification of Iguana-1 Phosphorylation via Western Blot

### Principle

The most direct method to assess **Iguana-1** activation is to measure its phosphorylation state. Western blotting using a phospho-specific antibody allows for the semi-quantitative detection of phosphorylated **Iguana-1** (p-**Iguana-1**) relative to the total **Iguana-1** protein in cell lysates. This method is fundamental for confirming ligand-induced activation or the inhibitory effect of a drug candidate.

### Experimental Protocol

- Cell Culture and Treatment:
  - Plate  $1 \times 10^6$  cancer cells (e.g., A549, MCF-7) in 6-well plates and allow them to adhere overnight.
  - Starve the cells in a serum-free medium for 12-18 hours to reduce basal RTK activity.
  - Treat cells with the **Iguana-1** ligand (100 ng/mL) or a test inhibitor for various time points (e.g., 0, 5, 15, 30 minutes).
- Cell Lysis:
  - Aspirate the medium and wash the cells once with ice-cold Phosphate-Buffered Saline (PBS).
  - Add 150  $\mu$ L of ice-cold RIPA lysis buffer supplemented with protease and phosphatase inhibitors.
  - Scrape the cells and transfer the lysate to a microcentrifuge tube. Incubate on ice for 30 minutes with vortexing every 10 minutes.
  - Centrifuge at 14,000 x g for 15 minutes at 4°C. Collect the supernatant.
- Protein Quantification:
  - Determine the protein concentration of each lysate using a BCA protein assay kit according to the manufacturer's instructions.
- SDS-PAGE and Western Blotting:
  - Normalize all samples to the same protein concentration (e.g., 20  $\mu$ g) with lysis buffer and Laemmli sample buffer.
  - Boil the samples at 95°C for 5 minutes.
  - Load samples onto a 4-12% Bis-Tris polyacrylamide gel and run until the dye front reaches the bottom.

- Transfer proteins to a PVDF membrane.
- Block the membrane with 5% Bovine Serum Albumin (BSA) in Tris-Buffered Saline with 0.1% Tween-20 (TBST) for 1 hour at room temperature.
- Incubate the membrane with a primary antibody against p-Iguana-1 (e.g., anti-pY1173) overnight at 4°C.
- Wash the membrane 3 times with TBST.
- Incubate with an HRP-conjugated secondary antibody for 1 hour at room temperature.
- Wash the membrane 3 times with TBST.
- Apply an Enhanced Chemiluminescence (ECL) substrate and visualize the bands using a chemiluminescence imaging system.
- Strip the membrane and re-probe for Total Iguana-1 and a loading control (e.g., GAPDH).

## Data Presentation

Table 1: Densitometry Analysis of p-Iguana-1 Levels Post-Ligand Stimulation

Time Point (minutes)	p-Iguana-1 (Relative Density)	Total Iguana-1 (Relative Density)	p-Iguana-1 / Total Iguana-1 Ratio
0	0.15	1.20	0.13
5	0.89	1.22	0.73
15	1.15	1.18	0.97

| 30 | 0.65 | 1.21 | 0.54 |

## Visualization

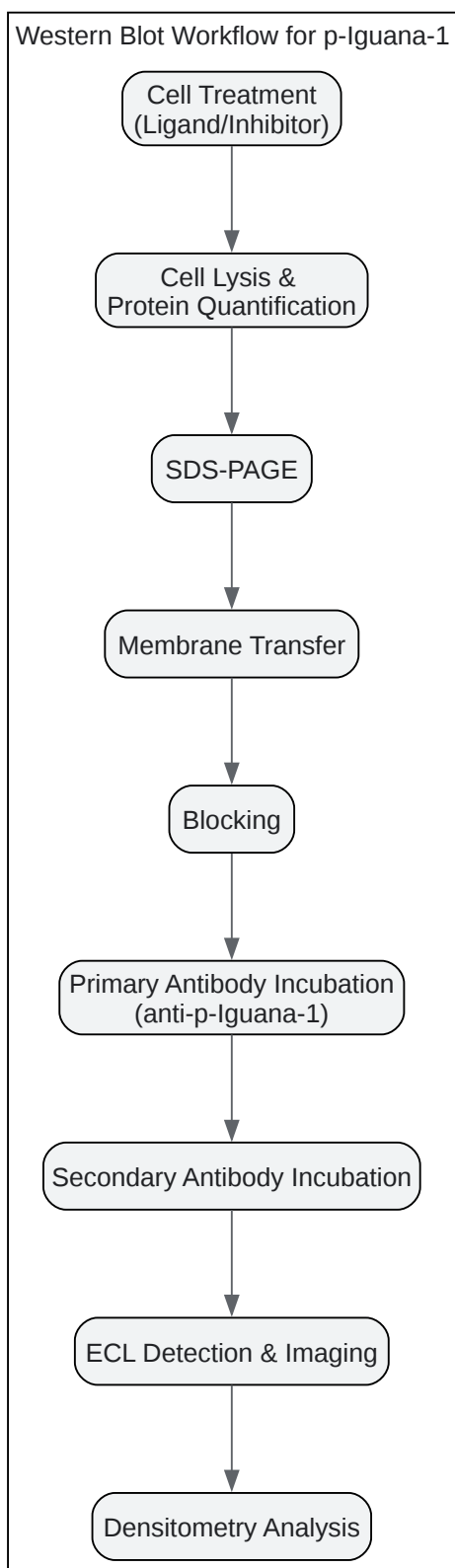

[Click to download full resolution via product page](#)

Western Blot workflow for detecting phosphorylated **Iguana-1**.

## Application Note 2: High-Throughput Screening with a Phospho-Iguana-1 ELISA

### Principle

An Enzyme-Linked Immunosorbent Assay (ELISA) provides a quantitative and high-throughput method to measure p-Iguana-1 levels. This sandwich ELISA protocol uses a capture antibody for total Iguana-1 and a detection antibody specific for the phosphorylated form, making it ideal for screening compound libraries for Iguana-1 inhibitors.

### Experimental Protocol

- Plate Coating:
  - Coat a 96-well high-binding microplate with an anti-Iguana-1 capture antibody (2 µg/mL in PBS) overnight at 4°C.
  - Wash the plate 4 times with Wash Buffer (PBS with 0.05% Tween-20).
- Blocking:
  - Block the plate with 200 µL/well of Assay Diluent (e.g., 1% BSA in PBS) for 2 hours at room temperature.
  - Wash the plate 4 times with Wash Buffer.
- Sample Addition:
  - Prepare cell lysates as described in the Western Blot protocol.
  - Normalize all lysates to a final protein concentration of 1 mg/mL in Assay Diluent.
  - Add 100 µL of each lysate or standard to the wells.
  - Incubate for 2 hours at room temperature with gentle shaking.
  - Wash the plate 4 times with Wash Buffer.

- Detection:
  - Add 100  $\mu$ L of a biotinylated anti-p-**Iguana-1** detection antibody (e.g., anti-pY1173-biotin) to each well.
  - Incubate for 1 hour at room temperature.
  - Wash the plate 4 times with Wash Buffer.
  - Add 100  $\mu$ L of Streptavidin-HRP conjugate to each well.
  - Incubate for 30 minutes at room temperature in the dark.
  - Wash the plate 4 times with Wash Buffer.
- Signal Development:
  - Add 100  $\mu$ L of TMB Substrate to each well.
  - Incubate for 15-20 minutes at room temperature in the dark until a blue color develops.
  - Add 50  $\mu$ L of Stop Solution (e.g., 2N H<sub>2</sub>SO<sub>4</sub>) to each well. The color will turn yellow.
  - Read the absorbance at 450 nm on a microplate reader.

## Data Presentation

Table 2: IC<sub>50</sub> Determination of Test Inhibitor (Compound-X) on **Iguana-1** Phosphorylation

Compound-X Conc. (nM)	Absorbance (450 nm)	% Inhibition
0 (Vehicle)	1.85	0
1	1.62	12.4
10	1.15	37.8
50	0.88	52.4
100	0.45	75.7
500	0.12	93.5

| Calculated IC50 || 45.2 nM |

Visualization

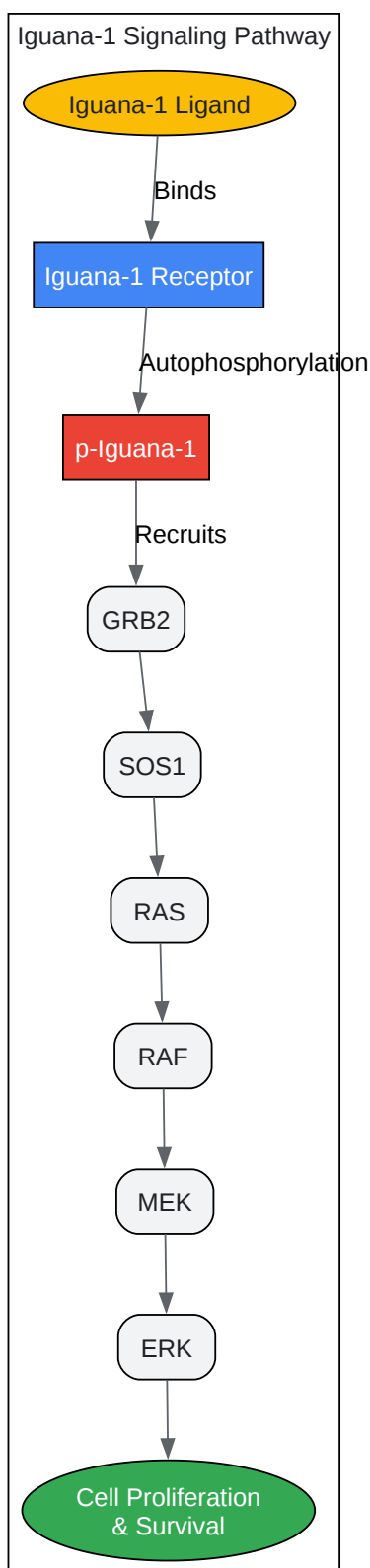

[Click to download full resolution via product page](#)

*The canonical IGU-MAPK signaling cascade initiated by **Iguana-1**.*



## Application Note 3: In Vitro Kinase Activity Assay

### Principle

This assay directly measures the enzymatic activity of purified **Iguana-1** by quantifying its ability to phosphorylate a generic or specific peptide substrate in vitro. The amount of phosphorylated substrate is typically measured using luminescence (e.g., ADP-Glo™ Kinase Assay), which quantifies ADP production as a direct output of kinase activity. This is the gold standard for assessing the potency of direct kinase inhibitors.

### Experimental Protocol

- Reagent Preparation:
  - Prepare a reaction buffer (e.g., 40 mM Tris, 20 mM MgCl<sub>2</sub>, 0.1 mg/mL BSA, pH 7.5).
  - Reconstitute purified, active **Iguana-1** kinase domain enzyme to a working concentration (e.g., 5 ng/μL).
  - Prepare a peptide substrate (e.g., poly-Glu-Tyr) and ATP at appropriate concentrations.
  - Serially dilute the test inhibitor in DMSO, then in reaction buffer.
- Kinase Reaction:
  - In a 96-well or 384-well plate, add 5 μL of the test inhibitor dilution.
  - Add 10 μL of a 2.5x enzyme/substrate mix (containing **Iguana-1** and peptide substrate).
  - Pre-incubate for 10 minutes at room temperature to allow the inhibitor to bind to the enzyme.
  - Initiate the reaction by adding 10 μL of a 2.5x ATP solution. The final reaction volume is 25 μL.
  - Incubate for 60 minutes at 30°C.
- Signal Detection (ADP-Glo™ Protocol):

- Stop the kinase reaction by adding 25  $\mu$ L of ADP-Glo™ Reagent. This depletes the remaining ATP.
- Incubate for 40 minutes at room temperature.
- Add 50  $\mu$ L of Kinase Detection Reagent to convert the generated ADP into ATP and then into a luminescent signal.
- Incubate for 30 minutes at room temperature.
- Measure luminescence using a plate-reading luminometer.

### Data Presentation

Table 3: Direct Inhibitory Activity of Compound-Y on **Iguana-1** Kinase

Compound-Y Conc. (nM)	Luminescence (RLU)	% Activity Remaining
<b>0 (Vehicle)</b>	<b>850,432</b>	<b>100</b>
0.5	765,388	90.0
2	552,781	65.0
10	416,712	49.0
50	127,565	15.0
200	42,521	5.0

| Calculated IC50 | | 9.8 nM |

### Visualization

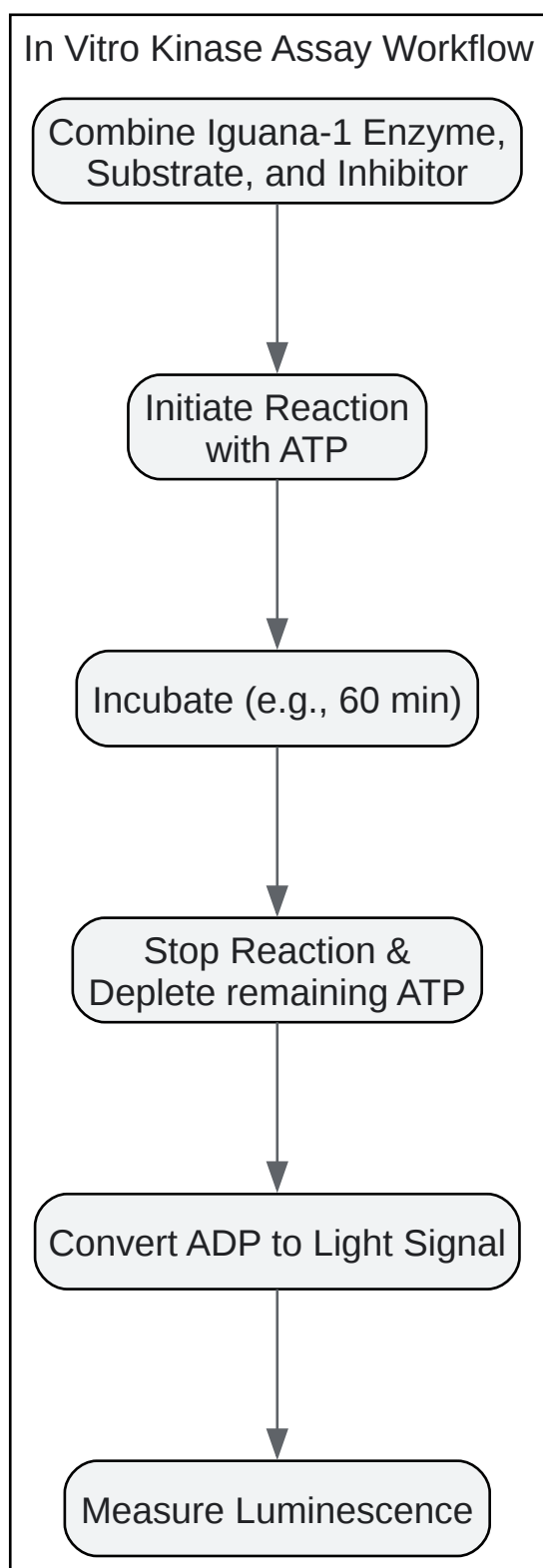

[Click to download full resolution via product page](#)

*Workflow for a luminescence-based in vitro kinase assay.*

- To cite this document: BenchChem. [Application Notes & Protocols for Measuring Iguana-1 Activity]. BenchChem, [2025]. [Online PDF]. Available at: [https://www.benchchem.com/product/b10854943#techniques-for-measuring-iguana-1-activity]

---

### Disclaimer & Data Validity:

The information provided in this document is for Research Use Only (RUO) and is strictly not intended for diagnostic or therapeutic procedures. While BenchChem strives to provide accurate protocols, we make no warranties, express or implied, regarding the fitness of this product for every specific experimental setup.

**Technical Support:** The protocols provided are for reference purposes. Unsure if this reagent suits your experiment? [[Contact our Ph.D. Support Team for a compatibility check](#)]

**Need Industrial/Bulk Grade?** [Request Custom Synthesis Quote](#)

## BenchChem

Our mission is to be the trusted global source of essential and advanced chemicals, empowering scientists and researchers to drive progress in science and industry.

### Contact

Address: 3281 E Guasti Rd

Ontario, CA 91761, United States

Phone: (601) 213-4426

Email: [info@benchchem.com](mailto:info@benchchem.com)