

Application Notes & Protocols: Gene Expression Analysis Following IMB-808 Treatment

Author: BenchChem Technical Support Team. **Date:** December 2025

Compound of Interest

Compound Name: IMB-808

Cat. No.: B1671743

[Get Quote](#)

For Researchers, Scientists, and Drug Development Professionals

Introduction

IMB-808 is a novel, selective dual agonist for Liver X Receptor alpha (LXR α) and Liver X Receptor beta (LXR β).^[1] LXRs are nuclear receptors that play a pivotal role in regulating the transcription of genes involved in cholesterol metabolism, reverse cholesterol transport, and inflammatory responses.^[1] Upon activation by agonists like **IMB-808**, LXRs form a heterodimer with the Retinoid X Receptor (RXR) and bind to LXR response elements (LXREs) in the promoter regions of target genes, thereby modulating their expression.^[2]

A key characteristic of **IMB-808** is its ability to induce the expression of genes involved in cholesterol efflux, such as ATP-binding cassette transporter A1 (ABCA1) and Apolipoprotein E (APOE), without significantly upregulating genes associated with lipogenesis, a common side effect of other LXR agonists.^{[1][2]} This selective modulation of gene expression makes **IMB-808** a promising therapeutic candidate for conditions like atherosclerosis. These application notes provide a comprehensive guide to analyzing the effects of **IMB-808** on gene expression in a research setting.

Data Presentation: Expected Gene Expression Changes

The following tables summarize the anticipated changes in gene expression in relevant cell lines (e.g., HepG2, RAW264.7, THP-1 macrophages) following treatment with **IMB-808**, based on its known mechanism of action.

Table 1: Key Target Genes in Reverse Cholesterol Transport

Gene Symbol	Gene Name	Expected Change with IMB-808	Function
ABCA1	ATP-binding cassette transporter A1	↑	Mediates cholesterol efflux to lipid-poor apolipoproteins.
ABCG1	ATP-binding cassette transporter G1	↑	Promotes cholesterol efflux to HDL particles.
APOE	Apolipoprotein E	↑	Ligand for lipoprotein receptors, involved in lipid transport.

Table 2: Key Target Genes in Lipogenesis

Gene Symbol	Gene Name	Expected Change with IMB-808	Function
SREBF1 (SREBP-1c)	Sterol regulatory element-binding protein 1	↔ or slight ↑	Master transcriptional regulator of fatty acid synthesis.
FASN	Fatty acid synthase	↔ or slight ↑	Catalyzes the synthesis of long-chain fatty acids.
ACACA (ACC)	Acetyl-CoA carboxylase alpha	↔ or slight ↑	Catalyzes the carboxylation of acetyl-CoA to malonyl-CoA, a key step in fatty acid synthesis.

Table 3: Genes Involved in Inflammation

Gene Symbol	Gene Name	Expected Change with IMB-808	Function
IL1B	Interleukin 1 beta	↓	Pro-inflammatory cytokine.
TNF	Tumor necrosis factor	↓	Pro-inflammatory cytokine.
CCL2 (MCP-1)	C-C motif chemokine ligand 2	↓	Chemokine that recruits monocytes/macrophages.

Signaling Pathway and Experimental Workflow

The following diagrams illustrate the LXR signaling pathway activated by **IMB-808** and a typical experimental workflow for analyzing the resulting gene expression changes.

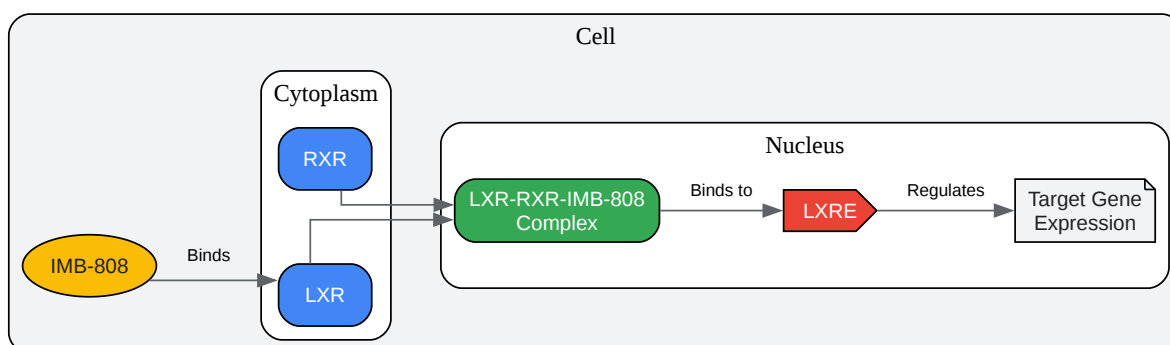

[Click to download full resolution via product page](#)

Caption: LXR signaling pathway activated by **IMB-808**.

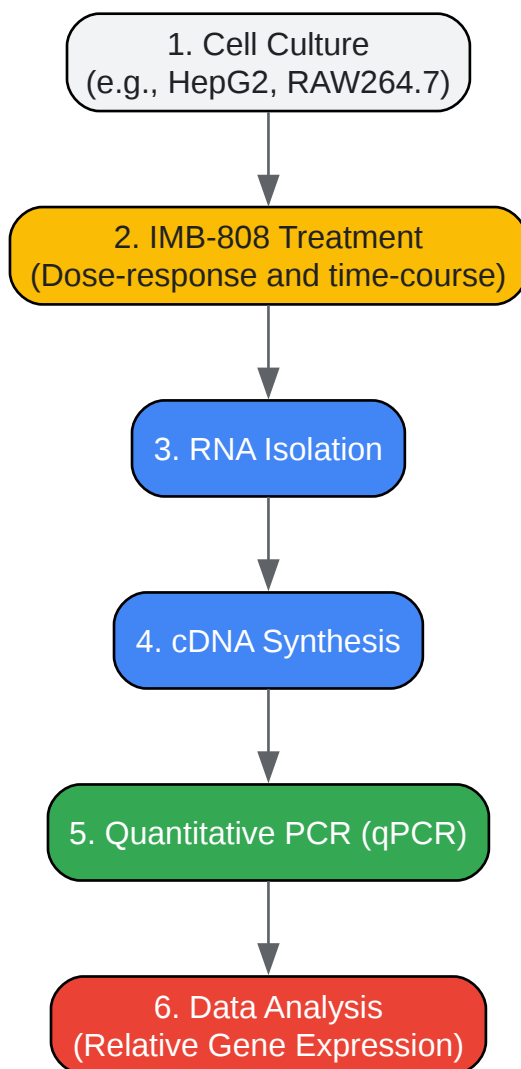

[Click to download full resolution via product page](#)

Caption: Experimental workflow for gene expression analysis.

Experimental Protocols

Protocol 1: Cell Culture and IMB-808 Treatment

- Cell Seeding:
 - Culture HepG2 or RAW264.7 cells in Dulbecco's Modified Eagle's Medium (DMEM) supplemented with 10% Fetal Bovine Serum (FBS) and 1% Penicillin-Streptomycin at 37°C in a humidified atmosphere with 5% CO₂.

- Seed cells in 6-well plates at a density of 5×10^5 cells per well and allow them to adhere overnight.
- **IMB-808** Preparation:
 - Prepare a stock solution of **IMB-808** (e.g., 10 mM in DMSO).
 - Prepare working solutions by diluting the stock solution in culture medium to the desired final concentrations (e.g., 0.1, 1, 10 μ M). Include a vehicle control (DMSO) at the same final concentration as the highest **IMB-808** concentration.
- Treatment:
 - Remove the old medium from the cells and wash once with Phosphate-Buffered Saline (PBS).
 - Add 2 mL of the medium containing the different concentrations of **IMB-808** or vehicle control to the respective wells.
 - Incubate the cells for the desired time period (e.g., 24 hours).

Protocol 2: RNA Isolation and Quantification

- Cell Lysis:
 - After treatment, remove the medium and wash the cells once with cold PBS.
 - Add 1 mL of TRIzol reagent (or equivalent) to each well and lyse the cells by pipetting up and down.
- RNA Isolation:
 - Follow the manufacturer's protocol for the RNA isolation reagent. This typically involves phase separation with chloroform and precipitation of RNA with isopropanol.
- RNA Wash and Resuspension:
 - Wash the RNA pellet with 75% ethanol.

- Air-dry the pellet and resuspend it in nuclease-free water.
- Quantification and Quality Control:
 - Measure the RNA concentration and purity using a spectrophotometer (e.g., NanoDrop). An A260/A280 ratio of ~2.0 is considered pure.
 - Assess RNA integrity by running an aliquot on an agarose gel or using an Agilent Bioanalyzer.

Protocol 3: cDNA Synthesis

- Reverse Transcription Reaction Setup:
 - In a PCR tube, combine 1 µg of total RNA, random hexamers or oligo(dT) primers, and nuclease-free water to the recommended volume.
 - Heat the mixture to 65°C for 5 minutes and then place on ice.
- Master Mix Preparation:
 - Prepare a master mix containing reverse transcriptase buffer, dNTPs, RNase inhibitor, and reverse transcriptase enzyme according to the manufacturer's instructions.
- cDNA Synthesis:
 - Add the master mix to the RNA-primer mixture.
 - Perform the reverse transcription reaction in a thermal cycler using the recommended temperature and time profile (e.g., 25°C for 10 min, 50°C for 50 min, 85°C for 5 min).

Protocol 4: Quantitative PCR (qPCR)

- qPCR Reaction Setup:
 - Prepare a qPCR master mix containing SYBR Green master mix, forward and reverse primers for the target genes and a housekeeping gene (e.g., GAPDH, ACTB), and nuclease-free water.

- Add the diluted cDNA to the master mix in a qPCR plate.
- Primer Design:
 - Design primers to be specific to the target gene and span an exon-exon junction to avoid amplification of genomic DNA. Validate primer efficiency.
- qPCR Program:
 - Run the qPCR plate in a real-time PCR machine using a standard cycling program (e.g., initial denaturation at 95°C for 10 min, followed by 40 cycles of 95°C for 15 sec and 60°C for 1 min).
- Data Analysis:
 - Determine the cycle threshold (Ct) values for each gene.
 - Calculate the relative gene expression using the $\Delta\Delta C_t$ method, normalizing the expression of the target genes to the housekeeping gene and comparing the treated samples to the vehicle control.

Disclaimer: These are example protocols and may need to be optimized for specific cell lines and experimental conditions. Always follow appropriate laboratory safety procedures.

Need Custom Synthesis?

BenchChem offers custom synthesis for rare earth carbides and specific isotopic labeling.

Email: info@benchchem.com or [Request Quote Online](#).

References

- 1. Identification of a Novel Liver X Receptor Agonist that Regulates the Expression of Key Cholesterol Homeostasis Genes with Distinct Pharmacological Characteristics - PubMed [pubmed.ncbi.nlm.nih.gov]
- 2. In search of nonlipogenic ABCA1 inducers (NLAI): precision coregulator TR-FRET identifies diverse signatures for LXR ligands [elifesciences.org]

- To cite this document: BenchChem. [Application Notes & Protocols: Gene Expression Analysis Following IMB-808 Treatment]. BenchChem, [2025]. [Online PDF]. Available at: [<https://www.benchchem.com/product/b1671743#gene-expression-analysis-after-imb-808-treatment>]

Disclaimer & Data Validity:

The information provided in this document is for Research Use Only (RUO) and is strictly not intended for diagnostic or therapeutic procedures. While BenchChem strives to provide accurate protocols, we make no warranties, express or implied, regarding the fitness of this product for every specific experimental setup.

Technical Support: The protocols provided are for reference purposes. Unsure if this reagent suits your experiment? [[Contact our Ph.D. Support Team for a compatibility check](#)]

Need Industrial/Bulk Grade? [Request Custom Synthesis Quote](#)

BenchChem

Our mission is to be the trusted global source of essential and advanced chemicals, empowering scientists and researchers to drive progress in science and industry.

Contact

Address: 3281 E Guasti Rd

Ontario, CA 91761, United States

Phone: (601) 213-4426

Email: info@benchchem.com