

Application Notes: Preparation and Long-Term Storage of MHY1485 Solutions

Author: BenchChem Technical Support Team. **Date:** December 2025

Compound of Interest

Compound Name: MHY1485

Cat. No.: B15604177

[Get Quote](#)

For Researchers, Scientists, and Drug Development Professionals

Introduction

MHY1485 is a potent, cell-permeable small molecule that functions as an activator of the mammalian target of rapamycin (mTOR), a crucial serine/threonine protein kinase.[1][2][3] The mTOR pathway is a central regulator of cell growth, proliferation, survival, and protein synthesis.[1] **MHY1485** exerts its effects by activating the mTORC1 complex, which subsequently phosphorylates downstream targets like S6K1 and rpS6.[2][4] A key aspect of its mechanism is the inhibition of autophagy; **MHY1485** suppresses the fusion between autophagosomes and lysosomes, leading to the accumulation of autophagic vacuoles.[1][5][6][7]

Given its role in fundamental cellular processes, **MHY1485** is a valuable tool in various research areas, including cancer biology, neurobiology, and studies on aging. The reliability and reproducibility of experimental results using **MHY1485** are critically dependent on the proper preparation, handling, and storage of its solutions. Degradation of the compound due to improper storage can lead to a significant loss of potency. These notes provide detailed protocols and stability data to ensure the consistent performance of **MHY1485** in research applications.

Quantitative Data Summary

The following tables summarize the key physical properties, solubility, and stability information for **MHY1485**.

Table 1: Chemical and Physical Properties of **MHY1485**

Property	Value
Molecular Formula	C ₁₇ H ₂₁ N ₇ O ₄
Molecular Weight	387.4 g/mol [1]
CAS Number	326914-06-1[1]
Appearance	Pale yellow solid
Purity	>98%[1][8]

Table 2: Solubility of **MHY1485** in Common Solvents

Solvent	Concentration	Notes
DMSO	Up to 20 mg/mL[1][8]	Moisture-absorbing DMSO can reduce solubility; use fresh solvent.[2] Gentle warming (50°C) or ultrasonication may be required to fully dissolve the compound.[2]
	12.5 mg/mL[9]	
	10 mg/mL[2]	
DMF	Up to 10 mg/mL[1][8]	
	5 mg/mL[7]	

Table 3: Recommended Storage Conditions and Stability

Form	Storage Temperature	Stability Period	Recommendations
Lyophilized Powder	Room Temperature	24 Months[1]	Store in a desiccated environment.
Stock Solution	-20°C	1 to 3 Months[1][2][8][9][10]	Aliquot to avoid repeated freeze-thaw cycles.[1][2]
Stock Solution	-80°C	6 to 12 Months[2][3][11]	Preferred for longer-term storage. Aliquot to prevent degradation.

Experimental Protocols

Protocol 1: Preparation of a 15 mM High-Concentration Stock Solution in DMSO

This protocol describes the preparation of a high-concentration stock solution for use in in vitro cell culture experiments.

Materials:

- **MHY1485** lyophilized powder
- Anhydrous, sterile Dimethyl Sulfoxide (DMSO)
- Sterile, conical-bottom polypropylene tubes
- Calibrated precision balance
- Vortex mixer
- Water bath or sonicator (optional)

Procedure:

- Equilibration: Allow the vial of **MHY1485** powder to equilibrate to room temperature for at least 15-20 minutes before opening to prevent moisture condensation.
- Weighing: Accurately weigh 5 mg of **MHY1485** powder and transfer it to a sterile polypropylene tube.
- Solvent Addition: Based on the product datasheet, add 0.86 mL of sterile, anhydrous DMSO to the tube containing the 5 mg of **MHY1485** to achieve a final concentration of 15 mM.[1]
- Dissolution: Cap the tube tightly and vortex thoroughly for 2-3 minutes until the powder is completely dissolved.
- Aiding Dissolution (if necessary): If the compound does not fully dissolve, warm the solution in a water bath at 37-50°C for 5-10 minutes or use a sonicator.[2] Vortex again to ensure homogeneity.
- Sterilization (Optional): If required for your application, filter the solution through a 0.22 µm DMSO-compatible syringe filter into a new sterile tube.
- Aliquoting and Storage: Dispense the stock solution into smaller, single-use aliquots in sterile cryovials. Store the aliquots at -80°C for long-term stability (up to 12 months) or at -20°C for shorter-term use (up to 3 months).[1][2][3]

Protocol 2: Preparation of Working Solutions for In Vitro Use

Procedure:

- Remove a single aliquot of the **MHY1485** stock solution from the -20°C or -80°C freezer.
- Thaw the aliquot at room temperature.
- Briefly centrifuge the vial to collect the solution at the bottom.
- Dilute the stock solution to the desired final working concentration directly in the cell culture medium. For example, to achieve a 10 µM final concentration in 10 mL of media, add 6.7 µL of the 15 mM stock solution.

- Mix the medium thoroughly by gentle inversion or pipetting immediately after adding the compound to ensure even distribution.
- Important: Do not re-freeze the thawed stock solution aliquot if it has been kept at room temperature for an extended period. Discard any unused portion of the working solution in media.

Visualizations and Workflows

MHY1485 Mechanism of Action

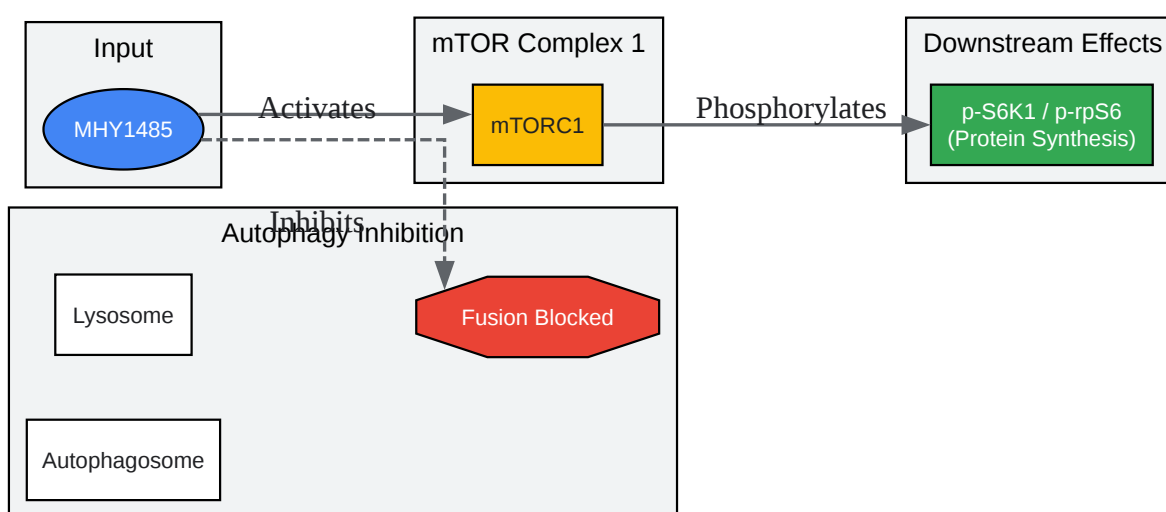

[Click to download full resolution via product page](#)

Caption: **MHY1485** activates mTORC1, promoting protein synthesis and inhibiting autophagy.

Experimental Workflow: Stock Solution Preparation

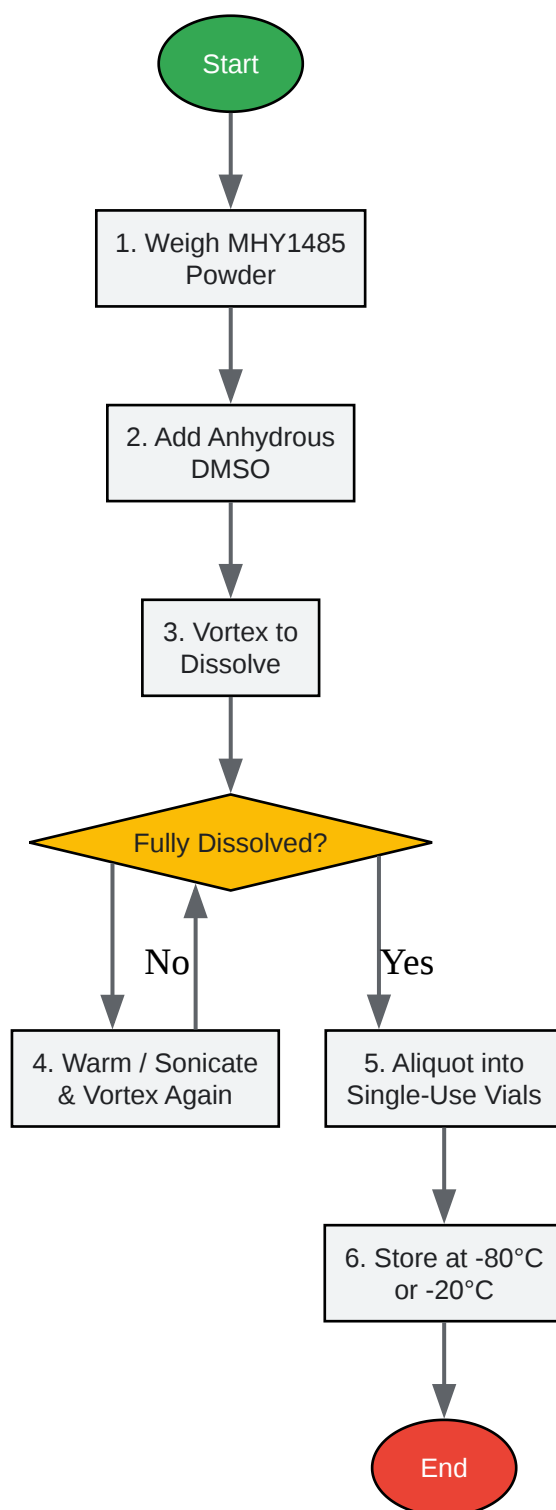

[Click to download full resolution via product page](#)

Caption: Workflow for preparing a stable **MHY1485** stock solution.

Logical Workflow: Solution Handling and Storage

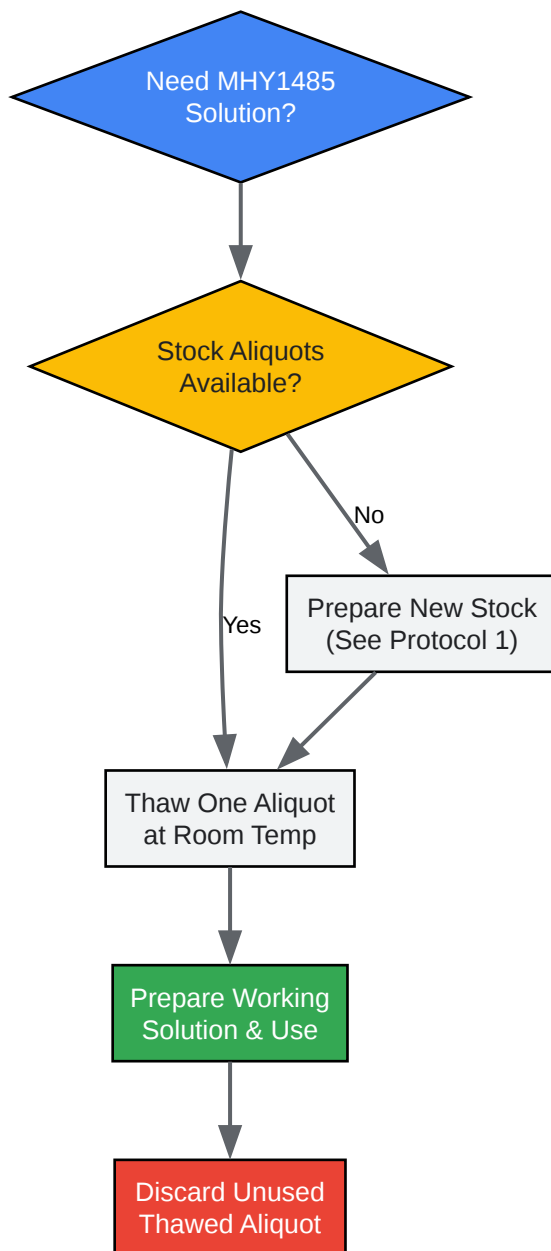

[Click to download full resolution via product page](#)

Caption: Decision tree for handling and using **MHY1485** solutions to ensure stability.

Need Custom Synthesis?

BenchChem offers custom synthesis for rare earth carbides and specific isotopic labeling.

Email: info@benchchem.com or [Request Quote Online](#).

References

- 1. MHY1485 | Cell Signaling Technology [cellsignal.com]
- 2. selleckchem.com [selleckchem.com]
- 3. medchemexpress.com [medchemexpress.com]
- 4. Frontiers | The Efficacy and Safety of the mTOR Signaling Pathway Activator, MHY1485, for in vitro Activation of Human Ovarian Tissue [frontiersin.org]
- 5. Inhibitory Effect of mTOR Activator MHY1485 on Autophagy: Suppression of Lysosomal Fusion - PMC [pmc.ncbi.nlm.nih.gov]
- 6. researchgate.net [researchgate.net]
- 7. caymanchem.com [caymanchem.com]
- 8. tribioscience.com [tribioscience.com]
- 9. MHY1485 ≥97% (HPLC), solid, mTOR activator, Calbiochem® | Sigma-Aldrich [sigmaaldrich.com]
- 10. MHY 1485 | MHY1485 | mTOR inhibitor | Hello Bio [helloworldbio.com]
- 11. medchemexpress.com [medchemexpress.com]
- To cite this document: BenchChem. [Application Notes: Preparation and Long-Term Storage of MHY1485 Solutions]. BenchChem, [2025]. [Online PDF]. Available at: [https://www.benchchem.com/product/b15604177#preparing-mhy1485-solutions-for-long-term-stability]

Disclaimer & Data Validity:

The information provided in this document is for Research Use Only (RUO) and is strictly not intended for diagnostic or therapeutic procedures. While BenchChem strives to provide accurate protocols, we make no warranties, express or implied, regarding the fitness of this product for every specific experimental setup.

Technical Support: The protocols provided are for reference purposes. Unsure if this reagent suits your experiment? [[Contact our Ph.D. Support Team for a compatibility check](#)]

Need Industrial/Bulk Grade? [Request Custom Synthesis Quote](#)

BenchChem

Our mission is to be the trusted global source of essential and advanced chemicals, empowering scientists and researchers to drive progress in science and industry.

Contact

Address: 3281 E Guasti Rd

Ontario, CA 91761, United States

Phone: (601) 213-4426

Email: info@benchchem.com