

# Application Note and Protocol: Vofopitant Dissolution in DMSO for Cell Culture

**Author:** BenchChem Technical Support Team. **Date:** December 2025

## Compound of Interest

Compound Name: Vofopitant

Cat. No.: B1662534

[Get Quote](#)

Audience: Researchers, scientists, and drug development professionals.

## Introduction

**Vofopitant** (also known as GR205171) is a potent and selective, non-peptide antagonist of the tachykinin neurokinin-1 (NK1) receptor.[1] It competitively blocks the binding of the endogenous ligand, Substance P, a neuropeptide involved in pain perception, inflammation, and emesis.[2] The NK1 receptor is a G protein-coupled receptor (GPCR) that, upon activation, initiates downstream signaling cascades.[2][3] Due to its mechanism, **Vofopitant** has been investigated for its antiemetic and anxiolytic properties.[1]

For in vitro studies, **Vofopitant** is typically dissolved in an organic solvent due to its limited aqueous solubility. Dimethyl sulfoxide (DMSO) is a common solvent of choice. This protocol provides a detailed methodology for preparing **Vofopitant** solutions in DMSO for use in cell culture applications, ensuring compound stability and minimizing solvent-induced cytotoxicity.

## Vofopitant and DMSO Specifications

The following table summarizes key quantitative data for **Vofopitant** and recommendations for using DMSO in cell culture.

Parameter	Value / Recommendation	Source(s)
Vofopitant Properties		
IUPAC Name	(2S,3S)-N-[(2-Methoxy-5-[5-(trifluoromethyl)tetrazol-1-yl]phenyl)methyl]-2-phenylpiperidin-3-amine	
Molecular Formula	C <sub>21</sub> H <sub>23</sub> F <sub>3</sub> N <sub>6</sub> O	
Molecular Weight	432.44 g/mol	
CAS Number	168266-90-8	
Solubility	Soluble in DMSO	
DMSO in Cell Culture		
Recommended Final Conc.	< 0.5% (v/v), with ≤ 0.1% (v/v) being preferable to avoid cytotoxic effects.	
Cytotoxicity	Can inhibit cell proliferation at concentrations >0.5%; significant toxicity often observed at ≥2%.	
Vehicle Control	Always include a control group treated with the same final concentration of DMSO as the experimental groups.	

## Vofopitant Mechanism of Action: NK1 Receptor Pathway

**Vofopitant** exerts its effect by blocking the Substance P (SP) binding site on the NK1 receptor. This inhibition prevents the activation of downstream signaling pathways, such as the MAPK cascade, which are involved in cellular responses like proliferation and inflammation.

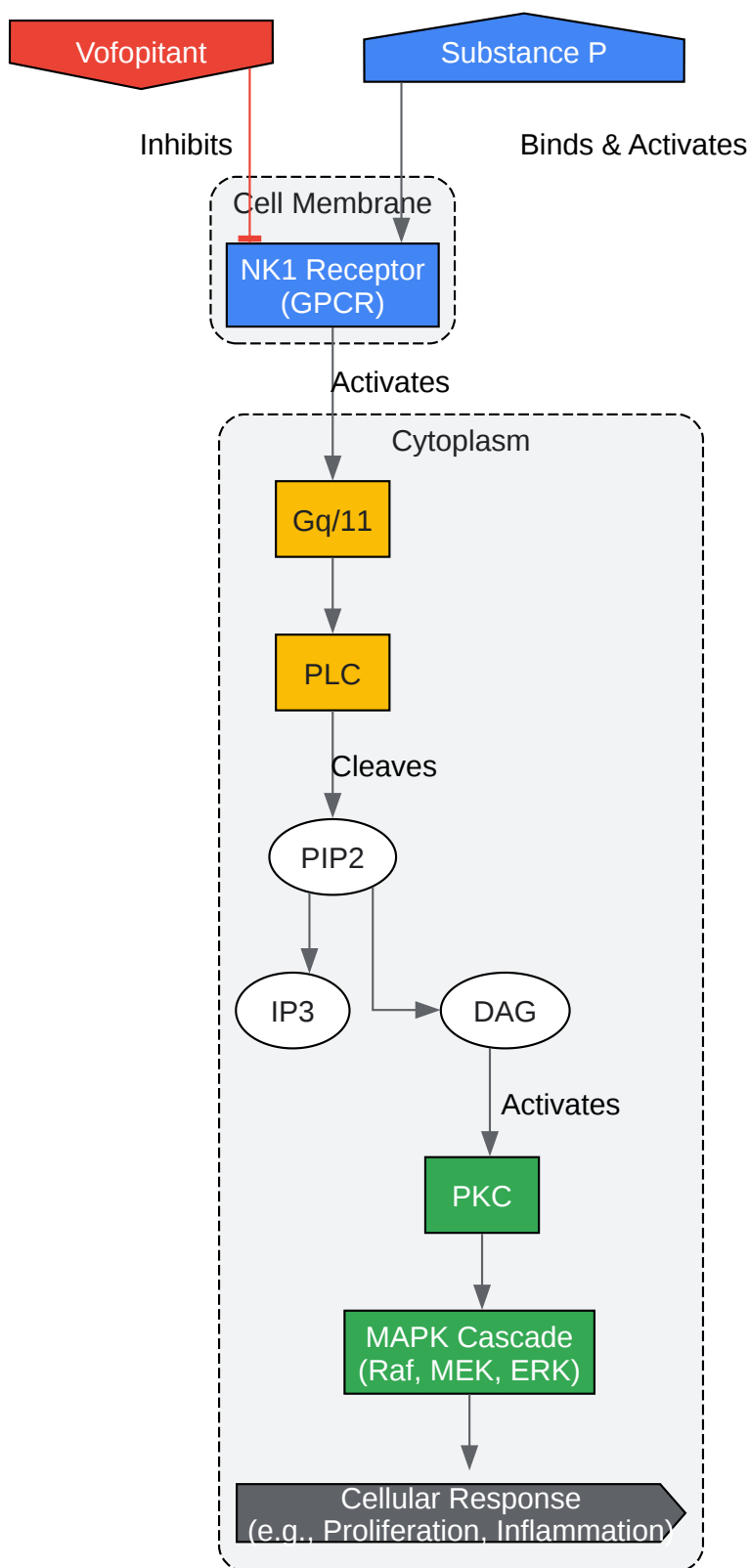

[Click to download full resolution via product page](#)

**Caption: Vofopitant** blocks the Substance P/NK1 receptor signaling pathway.

## Experimental Protocol

This protocol is divided into two main stages: preparing a concentrated stock solution and diluting it to working concentrations for cell treatment.

### 4.1. Part A: Preparation of **Vofopitant** Stock Solution (e.g., 10 mM in DMSO)

This procedure outlines how to prepare a 10 mM stock solution. Adjust calculations based on your desired concentration.

Materials:

- **Vofopitant** powder (MW: 432.44 g/mol )
- Anhydrous/Sterile Dimethyl Sulfoxide (DMSO)
- Sterile microcentrifuge tubes or amber glass vials
- Calibrated analytical balance
- Vortex mixer
- Ultrasonic water bath (optional, but recommended)

Procedure:

- Calculate Required Mass: Determine the mass of **Vofopitant** needed.
  - Formula:  $\text{Mass (mg)} = \text{Desired Concentration (mM)} \times \text{Desired Volume (mL)} \times \text{Molecular Weight (g/mol)}$
  - Example for 1 mL of 10 mM stock:  $\text{Mass (mg)} = 10 \text{ mmol/L} \times 0.001 \text{ L} \times 432.44 \text{ g/mol} = 4.32 \text{ mg}$
- Weighing: Carefully weigh out the calculated amount of **Vofopitant** powder and place it into a sterile microcentrifuge tube or vial. If the compound is toxic or of unknown toxicity, perform this step in a chemical fume hood.

- Solvent Addition: Add the calculated volume of 100% DMSO to the vial containing the **Vofopitant** powder.
- Dissolution:
  - Tightly cap the vial and vortex thoroughly for 1-2 minutes.
  - Visually inspect the solution for any undissolved particles.
  - If particulates remain, warm the solution in a 37°C water bath for 5-10 minutes, followed by brief vortexing.
  - For difficult-to-dissolve compounds, sonication in an ultrasonic bath for a few minutes can significantly aid dissolution.
- Sterility: DMSO is strongly bactericidal, so filtration of the 100% DMSO stock is generally not required. Ensure all handling is done using sterile techniques to prevent contamination.
- Storage:
  - For short-term storage (up to 1 month), store the stock solution at -20°C.
  - For long-term storage (up to 6 months), aliquot the stock solution into smaller, single-use volumes to avoid repeated freeze-thaw cycles and store at -80°C.

#### 4.2. Part B: Preparation of Working Solutions and Cell Treatment

This procedure describes how to dilute the DMSO stock solution into your cell culture medium to achieve the final desired treatment concentration. A stepwise dilution is recommended to prevent the compound from precipitating.

Materials:

- **Vofopitant** stock solution (10 mM in DMSO)
- Sterile complete cell culture medium (pre-warmed to 37°C)
- Sterile conical tubes or microcentrifuge tubes

#### Procedure:

- **Determine Final Concentrations:** Decide on the final concentrations of **Vofopitant** for your experiment (e.g., 1  $\mu$ M, 10  $\mu$ M, 100  $\mu$ M).
- **Calculate Dilutions:** Calculate the volume of stock solution needed. Ensure the final DMSO concentration remains below 0.5% (e.g., for a 1:1000 dilution, the final DMSO concentration will be 0.1%).
- **Perform Serial Dilution (Example for 10  $\mu$ M final):**
  - **Intermediate Dilution (Optional but Recommended):** Prepare an intermediate dilution by adding a small volume of the 10 mM stock solution to a larger volume of pre-warmed medium. For example, add 10  $\mu$ L of 10 mM stock to 990  $\mu$ L of medium to get a 100  $\mu$ M solution (in 0.1% DMSO). Vortex gently.
  - **Final Dilution:** Add the required volume of the intermediate solution to your cell culture plate wells containing medium to achieve the final concentration. For example, add 100  $\mu$ L of the 100  $\mu$ M intermediate solution to 900  $\mu$ L of medium in a well to reach a final concentration of 10  $\mu$ M.
- **Prepare Vehicle Control:** It is critical to have a control group that is treated with the same final concentration of DMSO as your highest dose experimental group. Prepare a "mock" treatment solution using only DMSO and culture medium.
- **Treat Cells:** Add the final working solutions (**Vofopitant** dilutions and vehicle control) to your cells and incubate under standard conditions.

## Experimental Workflow Diagram

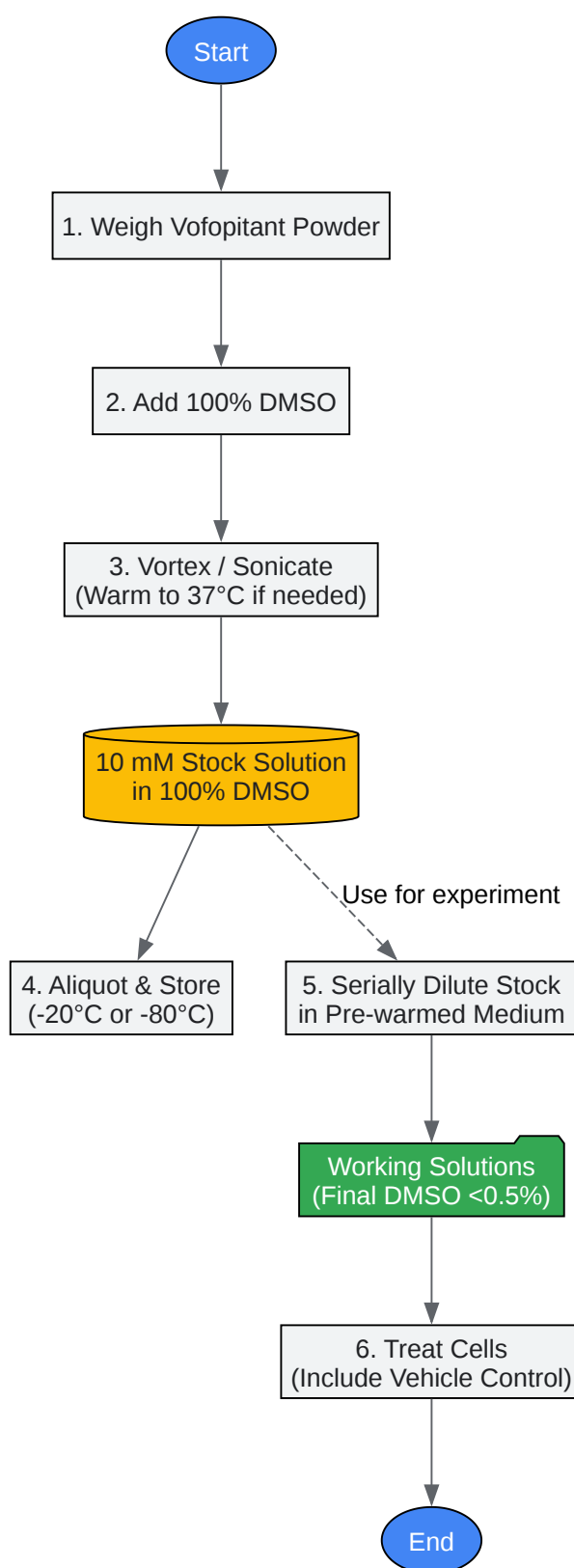

[Click to download full resolution via product page](#)

**Caption:** Workflow for preparing **Vofopitant** solutions for cell culture.

## Safety Precautions

- Always wear appropriate Personal Protective Equipment (PPE), including gloves, a lab coat, and safety glasses when handling **Vofopitant** and DMSO.
- DMSO can facilitate the absorption of other chemicals through the skin; handle with caution.
- Consult the Safety Data Sheet (SDS) for **Vofopitant** for specific handling and disposal instructions.

### Need Custom Synthesis?

BenchChem offers custom synthesis for rare earth carbides and specific isotopic labeling.

Email: [info@benchchem.com](mailto:info@benchchem.com) or [Request Quote Online](#).

## References

- 1. Vofopitant - Wikipedia [en.wikipedia.org]
- 2. Antiemetic Neurokinin-1 Receptor Blockers - StatPearls - NCBI Bookshelf [ncbi.nlm.nih.gov]
- 3. Biological and Pharmacological Aspects of the NK1-Receptor - PMC [pmc.ncbi.nlm.nih.gov]
- To cite this document: BenchChem. [Application Note and Protocol: Vofopitant Dissolution in DMSO for Cell Culture]. BenchChem, [2025]. [Online PDF]. Available at: [https://www.benchchem.com/product/b1662534#protocol-for-dissolving-vofopitant-in-dmso-for-cell-culture]

---

### Disclaimer & Data Validity:

The information provided in this document is for Research Use Only (RUO) and is strictly not intended for diagnostic or therapeutic procedures. While BenchChem strives to provide accurate protocols, we make no warranties, express or implied, regarding the fitness of this product for every specific experimental setup.



**Technical Support:** The protocols provided are for reference purposes. Unsure if this reagent suits your experiment? [[Contact our Ph.D. Support Team for a compatibility check](#)]

**Need Industrial/Bulk Grade?** [Request Custom Synthesis Quote](#)

## BenchChem

Our mission is to be the trusted global source of essential and advanced chemicals, empowering scientists and researchers to drive progress in science and industry.

### Contact

Address: 3281 E Guasti Rd

Ontario, CA 91761, United States

Phone: (601) 213-4426

Email: [info@benchchem.com](mailto:info@benchchem.com)