

Application Note: Tyrosinase-IN-16 for Skin Pigmentation Studies

Author: BenchChem Technical Support Team. **Date:** December 2025

Compound of Interest

Compound Name: Tyrosinase-IN-16

Cat. No.: B162660

[Get Quote](#)

For Researchers, Scientists, and Drug Development Professionals

Introduction

Melanin, the primary determinant of skin, hair, and eye color, is produced through a process called melanogenesis.[1][2] The dysregulation of this pathway can lead to hyperpigmentation disorders such as melasma and age spots.[3][4] At the heart of melanogenesis is the enzyme tyrosinase, which catalyzes the rate-limiting steps in melanin synthesis.[1][2][4] Specifically, it governs the hydroxylation of L-tyrosine to L-dihydroxyphenylalanine (L-DOPA) and the subsequent oxidation of L-DOPA to dopaquinone.[3][4] Consequently, the inhibition of tyrosinase is a primary strategy for the development of skin-lightening agents and treatments for hyperpigmentation.[1][2]

Tyrosinase-IN-16 is a potent and selective small molecule inhibitor of tyrosinase. Its application in dermatological and cosmetic research provides a valuable tool for studying the mechanisms of melanogenesis and for screening potential depigmenting agents. This document provides detailed protocols for the use of **Tyrosinase-IN-16** in common in vitro models of skin pigmentation.

Mechanism of Action

Tyrosinase-IN-16 acts as a competitive inhibitor of tyrosinase, binding to the active site of the enzyme and preventing the binding of its substrate, L-tyrosine. This leads to a reduction in the production of melanin precursors and, consequently, a decrease in overall melanin synthesis.

The primary signaling pathway influenced by **Tyrosinase-IN-16** is the melanogenesis pathway, which is regulated by various upstream factors, including the microphthalmia-associated transcription factor (MITF).^{[5][6]}

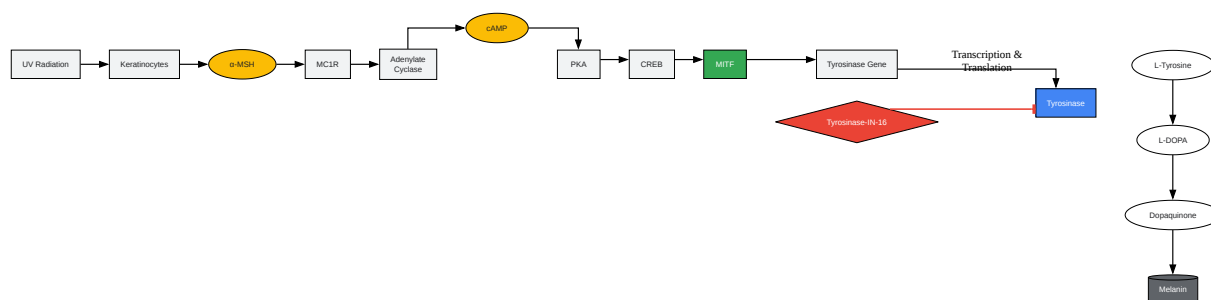

[Click to download full resolution via product page](#)

Caption: Simplified Melanogenesis Signaling Pathway and Inhibition by **Tyrosinase-IN-16**.

Quantitative Data Summary

The inhibitory effects of **Tyrosinase-IN-16** on tyrosinase activity and melanin production in B16F10 murine melanoma cells are summarized below.

Parameter	Tyrosinase-IN-16	Kojic Acid (Positive Control)
Mushroom Tyrosinase IC50	15 μ M	50 μ M
Cellular Tyrosinase IC50	25 μ M	100 μ M
Melanin Content Reduction at 50 μ M	60%	40%
Cell Viability at 50 μ M	>95%	>95%

Experimental Protocols

Mushroom Tyrosinase Activity Assay (Cell-Free)

This assay assesses the direct inhibitory effect of **Tyrosinase-IN-16** on purified mushroom tyrosinase.

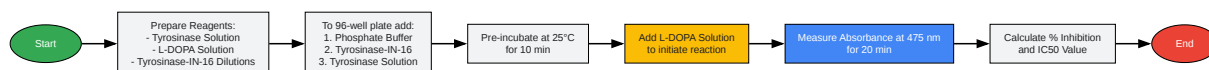

[Click to download full resolution via product page](#)

Caption: Workflow for the Mushroom Tyrosinase Activity Assay.

Materials:

- Mushroom Tyrosinase (e.g., Sigma-Aldrich, T3824)
- L-DOPA (e.g., Sigma-Aldrich, D9628)
- **Tyrosinase-IN-16**
- Potassium Phosphate Buffer (50 mM, pH 6.5)
- 96-well microplate

- Microplate reader

Procedure:

- Prepare a stock solution of mushroom tyrosinase in potassium phosphate buffer.
- Prepare serial dilutions of **Tyrosinase-IN-16** in the same buffer.
- In a 96-well plate, add 140 μ L of potassium phosphate buffer, 20 μ L of the **Tyrosinase-IN-16** solution (or buffer for control), and 20 μ L of the mushroom tyrosinase solution.
- Pre-incubate the plate at 25°C for 10 minutes.
- Initiate the reaction by adding 20 μ L of L-DOPA solution (10 mM).
- Immediately measure the absorbance at 475 nm every minute for 20 minutes using a microplate reader.
- Calculate the rate of dopachrome formation. The percentage of tyrosinase inhibition is calculated as: $[(A_{\text{control}} - A_{\text{sample}}) / A_{\text{control}}] * 100$.
- Determine the IC50 value by plotting the percentage of inhibition against the concentration of **Tyrosinase-IN-16**.

Cellular Tyrosinase Activity Assay

This protocol measures the effect of **Tyrosinase-IN-16** on tyrosinase activity within cultured B16F10 melanoma cells.

Materials:

- B16F10 melanoma cells
- Dulbecco's Modified Eagle's Medium (DMEM) with 10% Fetal Bovine Serum (FBS)
- **Tyrosinase-IN-16**
- α -Melanocyte-Stimulating Hormone (α -MSH)

- Lysis Buffer (e.g., 1% Triton X-100 in phosphate buffer)
- L-DOPA
- BCA Protein Assay Kit

Procedure:

- Seed B16F10 cells in a 6-well plate at a density of 4×10^5 cells/well and incubate for 24 hours.[7]
- Treat the cells with various concentrations of **Tyrosinase-IN-16** in the presence of 100 nM α -MSH for 48-72 hours to stimulate melanogenesis.[7]
- Wash the cells with ice-cold PBS and lyse them with lysis buffer.[7]
- Centrifuge the lysate at 12,000 x g for 15 minutes at 4°C to pellet cell debris.[7]
- Collect the supernatant and determine the protein concentration using a BCA assay.
- In a 96-well plate, add 90 μ L of the cell lysate (normalized for protein concentration) and 10 μ L of 15 mM L-DOPA.[7]
- Incubate at 37°C for 1 hour and measure the absorbance at 475 nm.[7]
- Calculate and normalize the tyrosinase activity against the total protein concentration.

Melanin Content Assay

This assay quantifies the total melanin content in B16F10 cells following treatment with **Tyrosinase-IN-16**.

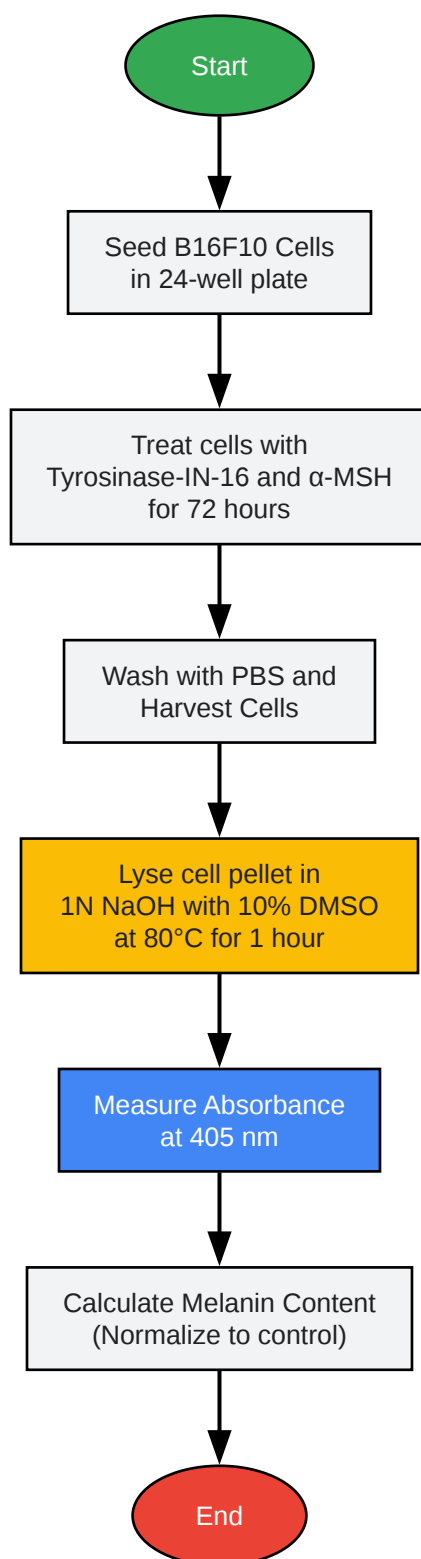

[Click to download full resolution via product page](#)

Caption: Workflow for the Cellular Melanin Content Assay.

Materials:

- B16F10 melanoma cells
- DMEM with 10% FBS
- **Tyrosinase-IN-16**
- α -MSH
- 1N NaOH with 10% DMSO

Procedure:

- Seed B16F10 cells in a 24-well plate at a density of 2×10^4 cells/well.[8]
- After 24 hours, treat the cells with various concentrations of **Tyrosinase-IN-16** and 100 nM α -MSH for 72 hours.
- Wash the cells with PBS and harvest the cell pellets.
- Solubilize the melanin by incubating the pellets in 1N NaOH containing 10% DMSO at 80°C for 1 hour.
- Transfer the lysate to a 96-well plate and measure the absorbance at 405 nm.[8]
- The melanin content is expressed as a percentage of the control group.

Conclusion

Tyrosinase-IN-16 is an effective tool for in vitro studies of skin pigmentation. The protocols outlined in this application note provide a robust framework for evaluating its efficacy and mechanism of action. These assays can be adapted for high-throughput screening of other potential tyrosinase inhibitors, aiding in the discovery and development of novel agents for dermatological and cosmetic applications.

Need Custom Synthesis?

BenchChem offers custom synthesis for rare earth carbides and specific isotopic labeling.

Email: info@benchchem.com or [Request Quote Online](#).

References

- 1. Skin whitening agents: medicinal chemistry perspective of tyrosinase inhibitors - PMC [pmc.ncbi.nlm.nih.gov]
- 2. tandfonline.com [tandfonline.com]
- 3. biofor.co.il [biofor.co.il]
- 4. researchgate.net [researchgate.net]
- 5. mdpi.com [mdpi.com]
- 6. Upregulation of Melanogenesis and Tyrosinase Activity: Potential Agents for Vitiligo - PMC [pmc.ncbi.nlm.nih.gov]
- 7. 2.8. Tyrosinase activity assay [bio-protocol.org]
- 8. 4.4. Melanin Content and Tyrosinase Activity Assay in B16F10 and HEMs [bio-protocol.org]
- To cite this document: BenchChem. [Application Note: Tyrosinase-IN-16 for Skin Pigmentation Studies]. BenchChem, [2025]. [Online PDF]. Available at: [https://www.benchchem.com/product/b162660#tyrosinase-in-16-application-in-skin-pigmentation-studies]

Disclaimer & Data Validity:

The information provided in this document is for Research Use Only (RUO) and is strictly not intended for diagnostic or therapeutic procedures. While BenchChem strives to provide accurate protocols, we make no warranties, express or implied, regarding the fitness of this product for every specific experimental setup.

Technical Support: The protocols provided are for reference purposes. Unsure if this reagent suits your experiment? [[Contact our Ph.D. Support Team for a compatibility check](#)]

Need Industrial/Bulk Grade? [Request Custom Synthesis Quote](#)

BenchChem

Our mission is to be the trusted global source of essential and advanced chemicals, empowering scientists and researchers to drive progress in science and industry.

Contact

Address: 3281 E Guasti Rd

Ontario, CA 91761, United States

Phone: (601) 213-4426

Email: info@benchchem.com