

Application Note: Preparation of Deltasonamide 2 (TFA) Stock Solution in DMSO

Author: BenchChem Technical Support Team. **Date:** December 2025

Compound of Interest

Compound Name: Deltasonamide 2 (TFA)

Cat. No.: B2513725

[Get Quote](#)

Audience: Researchers, scientists, and drug development professionals.

Purpose: This document provides a detailed protocol for the preparation, storage, and handling of a stock solution of Deltasonamide 2 (TFA salt) using dimethyl sulfoxide (DMSO) as the solvent. Adherence to this protocol will help ensure the integrity and stability of the compound for use in various experimental assays.

Introduction: Deltasonamide 2 is a potent and competitive inhibitor of phosphodiesterase δ (PDE δ) with a high affinity, exhibiting a dissociation constant (Kd) of approximately 385 pM.[1][2][3] It is a valuable tool for studying the role of PDE δ in cellular signaling pathways, particularly in the context of KRas-driven cancers. Proper preparation of a stock solution is the first critical step for obtaining reliable and reproducible experimental results. DMSO is a common solvent for dissolving hydrophobic compounds like Deltasonamide 2 for in vitro studies.[4][5][6][7]

I. Quantitative Data Summary

The following table summarizes the key quantitative data for **Deltasonamide 2 (TFA)** and its solubility in DMSO.

Property	Value	Reference
Chemical Name	Deltasonamide 2 (TFA)	[2]
Molecular Weight	761.27 g/mol	[2][8]
CAS Number	2235358-74-2	[2]
Appearance	White to off-white solid	[2]
Solubility in DMSO	125 mg/mL (164.20 mM)	[2]
Recommended Storage (Solid)	4°C, sealed, away from moisture	[2]
Recommended Storage (Stock Solution)	-80°C for 6 months; -20°C for 1 month	[1][2]

II. Experimental Protocol: Preparing a 10 mM Stock Solution

This protocol describes the preparation of a 10 mM stock solution of **Deltasonamide 2 (TFA)** in DMSO.

A. Materials and Equipment:

- Deltasonamide 2 (TFA salt)
- Anhydrous or high-purity Dimethyl Sulfoxide (DMSO)
- Sterile, nuclease-free microcentrifuge tubes (e.g., 1.5 mL or 2.0 mL)[5]
- Calibrated analytical balance
- Calibrated micropipettes and sterile, nuclease-free pipette tips[5]
- Vortex mixer
- Ultrasonic bath (optional, for aiding dissolution)[1]

- Personal Protective Equipment (PPE): safety glasses, lab coat, and chemical-resistant gloves[5]

B. Pre-Protocol Preparations:

- Before opening, allow the vial of **Deltasonamide 2 (TFA)** to equilibrate to room temperature to prevent condensation of moisture, which can affect the stability of the lyophilized powder. [9][10][11]
- Ensure that all equipment, including microcentrifuge tubes and pipette tips, are sterile and free of contaminants.[5]
- Work in a clean and, if possible, sterile environment, such as a laminar flow hood, especially if the stock solution will be used for cell culture experiments.[5]

C. Step-by-Step Procedure:

- Weighing the Compound:
 - Tare the analytical balance with a sterile microcentrifuge tube.
 - Carefully weigh the desired amount of **Deltasonamide 2 (TFA)** into the tube. For a 1 mL final volume of a 10 mM stock solution, you will need 7.61 mg.
 - Calculation:
 - Molecular Weight (MW) = 761.27 g/mol
 - Desired Concentration (C) = 10 mM = 0.01 mol/L
 - Desired Volume (V) = 1 mL = 0.001 L
 - Mass (m) = C * V * MW = 0.01 mol/L * 0.001 L * 761.27 g/mol = 0.00761 g = 7.61 mg
- Adding the Solvent:
 - Using a calibrated micropipette, add the calculated volume of DMSO to the microcentrifuge tube containing the weighed compound. For the example above, add 1 mL

of DMSO.

- It is recommended to use newly opened, high-purity DMSO, as hygroscopic DMSO can negatively impact the solubility of the product.[2]
- Dissolution:
 - Close the tube tightly and vortex the solution for 30-60 seconds to facilitate dissolution.[5]
 - Visually inspect the solution to ensure the compound has completely dissolved, resulting in a clear solution with no visible particulates.[10]
 - If the compound does not dissolve completely with vortexing, sonication in an ultrasonic bath for a few minutes can be used to aid dissolution.[9] Gentle warming to 37°C may also help.[1]
- Aliquoting and Storage:
 - To avoid repeated freeze-thaw cycles, which can degrade the compound, it is crucial to aliquot the stock solution into smaller, single-use volumes.[4][9][12]
 - Dispense the stock solution into sterile, nuclease-free microcentrifuge tubes in volumes appropriate for your planned experiments (e.g., 10 µL, 20 µL, or 50 µL aliquots).
 - Label each aliquot clearly with the compound name, concentration, date of preparation, and solvent.
 - For long-term storage (up to 6 months), store the aliquots at -80°C. For short-term storage (up to 1 month), -20°C is acceptable.[1][2]

III. Signaling Pathway and Workflow Diagrams

Diagram 1: Simplified KRas-PDEδ Signaling Pathway

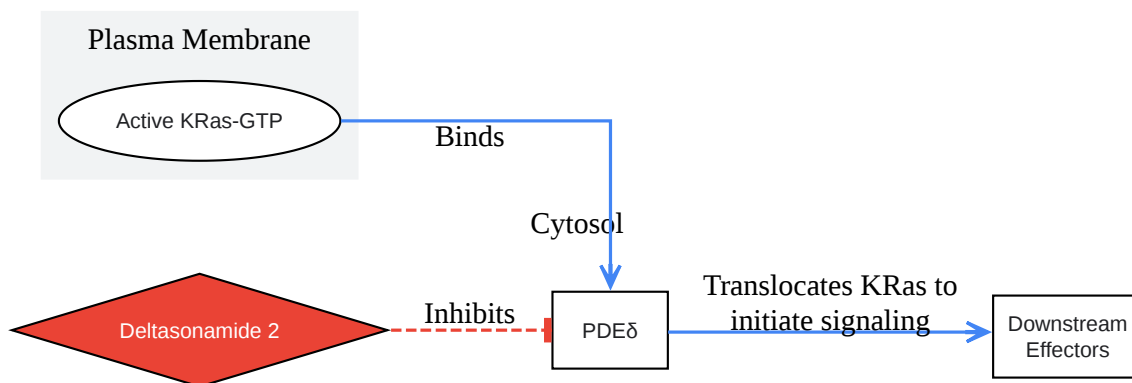

[Click to download full resolution via product page](#)

A simplified diagram of the KRas-PDE δ signaling interaction and the inhibitory action of Deltasonamide 2.

Diagram 2: Experimental Workflow for Stock Solution Preparation

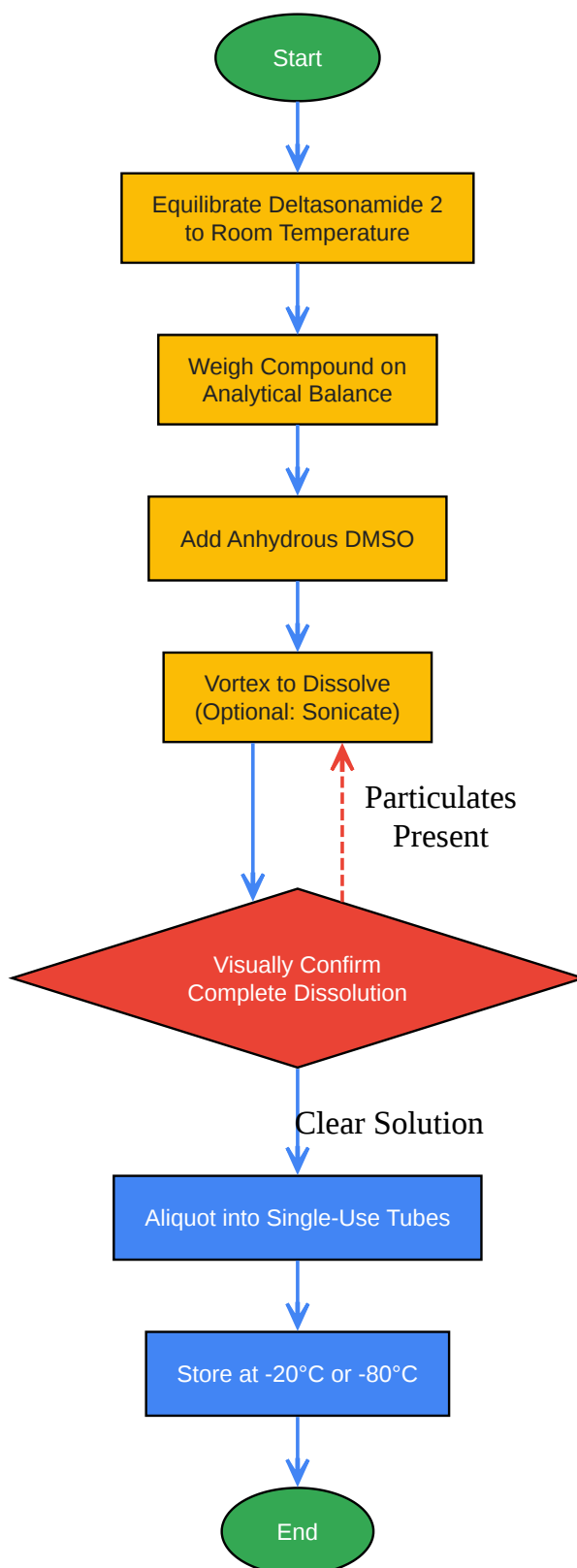

[Click to download full resolution via product page](#)

A step-by-step workflow for the preparation of a Deltasonamide 2 stock solution in DMSO.

Need Custom Synthesis?

BenchChem offers custom synthesis for rare earth carbides and specific isotopic labeling.

Email: info@benchchem.com or [Request Quote Online](#).

References

- 1. glpbio.com [glpbio.com]
- 2. medchemexpress.com [medchemexpress.com]
- 3. medchemexpress.com [medchemexpress.com]
- 4. medchemexpress.com [medchemexpress.com]
- 5. lifetein.com [lifetein.com]
- 6. genscript.com [genscript.com]
- 7. biocat.com [biocat.com]
- 8. Deltasonamide 1 TFA|CAS 2235358-73-1|DC Chemicals [dcchemicals.com]
- 9. sigmaaldrich.com [sigmaaldrich.com]
- 10. Peptide Solubility and Storage Tips | Product Guides | Biosynth [biosynth.com]
- 11. documents.thermofisher.com [documents.thermofisher.com]
- 12. biomatik.com [biomatik.com]
- To cite this document: BenchChem. [Application Note: Preparation of Deltasonamide 2 (TFA) Stock Solution in DMSO]. BenchChem, [2025]. [Online PDF]. Available at: [<https://www.benchchem.com/product/b2513725#preparing-deltasonamide-2-tfa-stock-solution-with-dmso>]

Disclaimer & Data Validity:

The information provided in this document is for Research Use Only (RUO) and is strictly not intended for diagnostic or therapeutic procedures. While BenchChem strives to provide accurate protocols, we make no warranties, express or implied, regarding the fitness of this product for every specific experimental setup.

Technical Support: The protocols provided are for reference purposes. Unsure if this reagent suits your experiment? [[Contact our Ph.D. Support Team for a compatibility check](#)]

Need Industrial/Bulk Grade? [Request Custom Synthesis Quote](#)

BenchChem

Our mission is to be the trusted global source of essential and advanced chemicals, empowering scientists and researchers to drive progress in science and industry.

Contact

Address: 3281 E Guasti Rd

Ontario, CA 91761, United States

Phone: (601) 213-4426

Email: info@benchchem.com