

Application Note: Investigating Drug-Induced Changes in Cellular ATP with ATP-Red 1

Author: BenchChem Technical Support Team. **Date:** December 2025

Compound of Interest

Compound Name: ATP-Red 1

Cat. No.: B560525

[Get Quote](#)

Audience: Researchers, scientists, and drug development professionals.

Introduction

Adenosine triphosphate (ATP) is the principal energy currency of the cell, fueling a vast array of biological processes. Consequently, cellular ATP concentration is a critical indicator of metabolic activity, cell health, and proliferation.[1] Many pharmacological agents exert their effects, either intentionally or as off-target toxicity, by disrupting cellular bioenergetics. Therefore, monitoring drug-induced changes in ATP levels is crucial in drug discovery and development for assessing compound efficacy and potential toxicity.[2][3]

ATP-Red 1 is a highly selective, cell-permeable, fluorescent probe designed for the real-time detection of ATP in living cells. It localizes primarily within the mitochondria, the powerhouse of the cell, making it an excellent tool for investigating drugs that target mitochondrial function. The probe is non-fluorescent in its native state but exhibits a significant increase in fluorescence upon binding to ATP, allowing for a direct and quantitative assessment of intracellular ATP fluctuations. This application note provides detailed protocols for using **ATP-Red 1** to measure changes in cellular ATP levels following drug treatment, utilizing fluorescence microscopy and flow cytometry.

Mechanism of Action

ATP-Red 1 is a multisite-binding, switchable fluorescent probe. In the absence of ATP, the molecule exists in a closed, non-fluorescent spirocyclic form. Upon encountering ATP, the

probe undergoes a multi-site interaction with the amine, phosphate, and ribose moieties of the ATP molecule. This binding event breaks a covalent bond in the probe, forcing the spirocycle to open. This conformational change results in a significant "turn-on" red fluorescence response. The fluorescence intensity of **ATP-Red 1** is directly proportional to the ATP concentration over a physiological range. The probe is highly selective for ATP, with minimal cross-reactivity to other nucleotides like ADP and AMP or various cellular analytes.

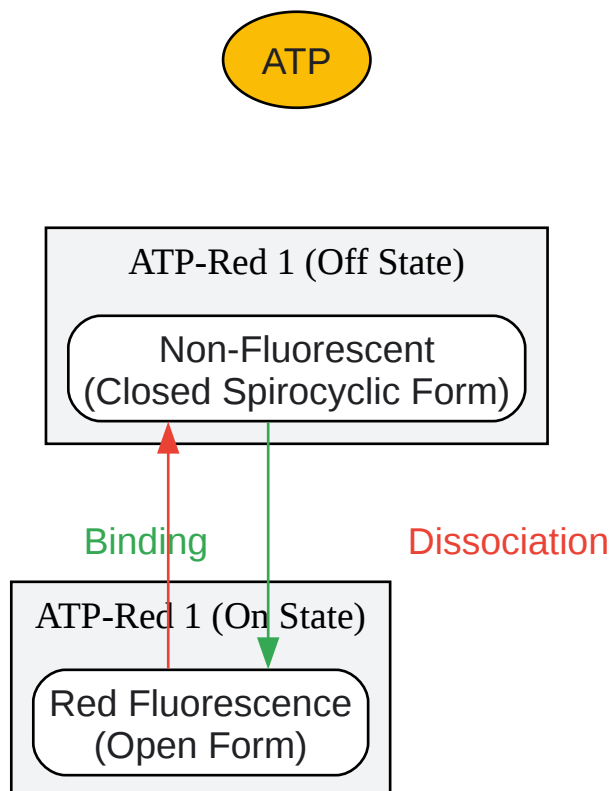

[Click to download full resolution via product page](#)

Caption: Mechanism of **ATP-Red 1** fluorescence activation.

Experimental Protocols

These protocols provide a framework for using **ATP-Red 1**. Optimal conditions, such as cell density and probe concentration, should be determined empirically for specific cell types and experimental setups.

Reagent Preparation

- **ATP-Red 1 Stock Solution (10 mM):**
 - Before opening, briefly centrifuge the vial to ensure the lyophilized powder is at the bottom.
 - Warm the vial to room temperature.
 - Add the appropriate volume of high-quality, anhydrous DMSO to create a 5-10 mM stock solution (e.g., for 1 mg of **ATP-Red 1** with a MW of 561.48, add 178 μ L of DMSO for a 10 mM stock).
 - Mix thoroughly by vortexing.
 - Aliquot the stock solution into smaller volumes to avoid repeated freeze-thaw cycles and store at -20°C or -80°C , protected from light.
- **ATP-Red 1 Working Solution (5-10 μ M):**
 - On the day of the experiment, dilute the 10 mM stock solution into a serum-free cell culture medium or PBS to a final working concentration of 5-10 μ M.
 - This working solution should be prepared fresh and used immediately. Protect from light.

Protocol for Drug Treatment and Cell Staining

This workflow is designed for a 96-well plate format but can be adapted for other culture vessels.

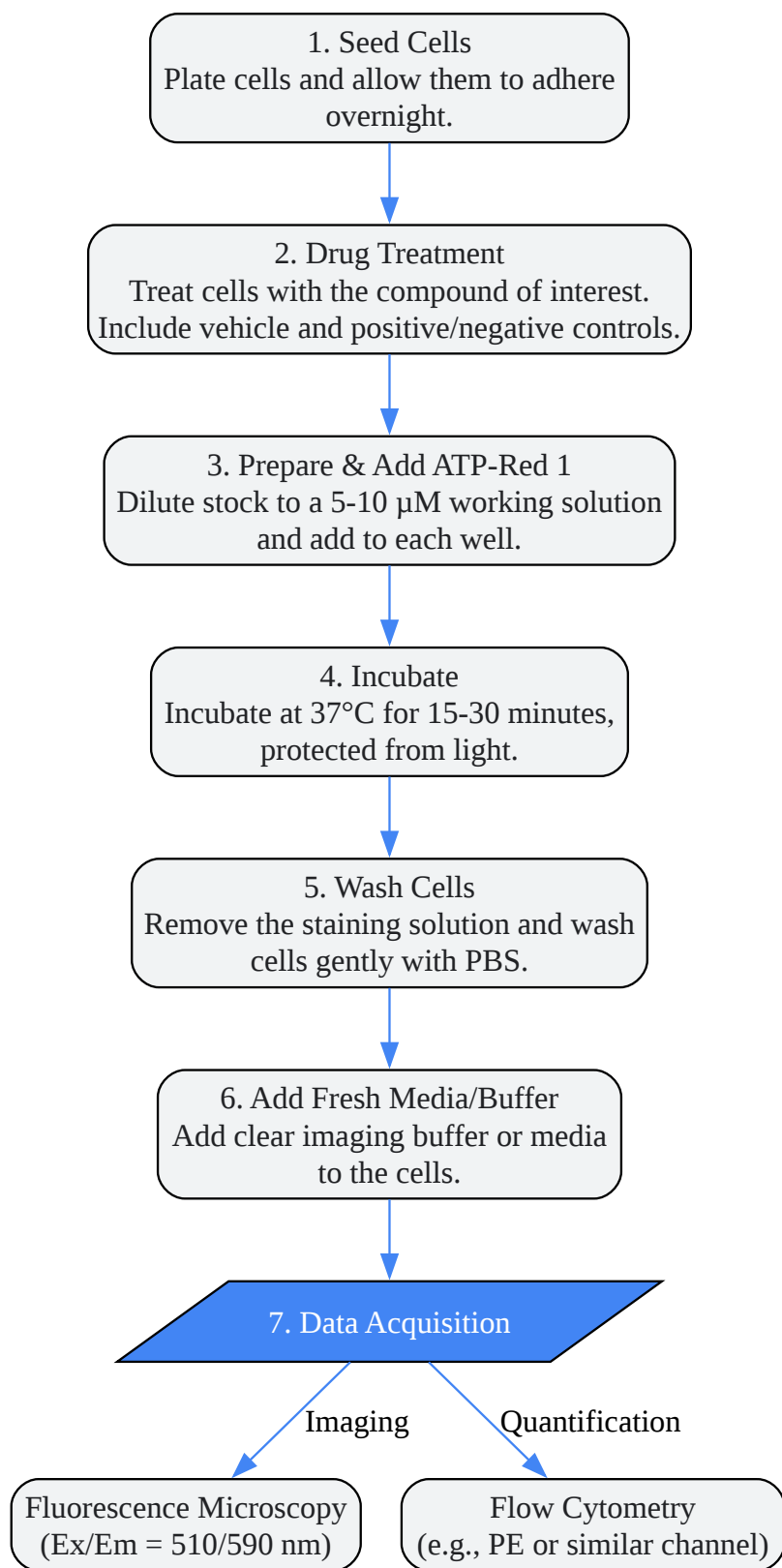

[Click to download full resolution via product page](#)

Caption: Experimental workflow for drug screening with **ATP-Red 1**.

- **Cell Seeding:** Seed cells in a 96-well plate (or other appropriate culture vessel) at a density that ensures they are in the logarithmic growth phase at the time of the experiment. Allow cells to adhere and recover overnight. A typical density is 2×10^5 cells/well in 100 μ L.
- **Drug Treatment:** Remove the culture medium and add fresh medium containing the drug of interest at various concentrations. Include appropriate controls:
 - **Vehicle Control:** Cells treated with the same concentration of the drug's solvent (e.g., DMSO).
 - **Positive Control (ATP depletion):** Cells treated with a known mitochondrial inhibitor like KCN, rotenone, or CCCP.
 - **Positive Control (ATP increase):** In some contexts, drugs like camptothecin have been shown to increase ATP levels in the early stages of apoptosis.
- **Incubation:** Incubate the cells with the drug for the desired period (e.g., 2, 4, 6, 16, or 24 hours), depending on the drug's mechanism of action.
- **Staining:** After drug treatment, carefully remove the medium. Add 100 μ L of the freshly prepared **ATP-Red 1** working solution (5-10 μ M) to each well.
- **Incubation:** Incubate the plate at 37°C for 15-30 minutes, protected from light.
- **Wash:** Remove the **ATP-Red 1** working solution and wash the cells twice with warm PBS or a suitable imaging buffer.
- **Analysis:** Add fresh PBS or culture medium to the wells and proceed immediately to data acquisition.

Data Acquisition

- **Fluorescence Microscopy:**
 - Image the cells using a fluorescence microscope equipped with filters appropriate for the probe's spectral properties (Excitation/Emission \approx 510/590 nm).

- Use consistent acquisition settings (e.g., exposure time, gain) across all wells to ensure comparability.
- A decrease in red fluorescence intensity in drug-treated cells compared to the vehicle control indicates ATP depletion. Conversely, an increase suggests a rise in ATP levels.
- Flow Cytometry:
 - After the wash step, detach the cells using a gentle, non-enzymatic cell dissociation buffer or trypsin.
 - Resuspend the cells in PBS or FACS buffer to get a single-cell suspension.
 - Analyze the fluorescence intensity of the cell population using a flow cytometer. The red fluorescence from **ATP-Red 1** can typically be detected in the PE channel.
 - The geometric mean fluorescence intensity (gMFI) of the cell population can be used to quantify the relative changes in ATP levels between different treatment groups.

Data Presentation and Expected Results

Quantitative data should be summarized to compare the effects of different compounds. The tables below provide examples of drug-induced ATP changes observed in various studies, which can be used as a reference for designing experiments with **ATP-Red 1**.

Table 1: Examples of Drug-Induced ATP Depletion

Compound	Cell Line	Treatment	Assay Used	Result (Relative to Reference Control)
KCN	OSCC Cells	2.5 μ M, 20 min	ATP-Red 1	Weaker fluorescence (qualitative)
Rotenone / 2-Deoxy-D-glucose	Various	16 h	CellTiter-Glo	~90-95% ATP Depletion
CCCP / Dasatinib	Various	16 h	CellTiter-Glo	Up to 100-fold ATP decrease
IACS-010759 / Vinorelbine	OCI-AML2	16 h	CellTiter-Glo	1.2 to 4-fold ATP decrease

Table 2: Examples of Drug-Induced ATP Increase

Compound	Cell Line	Treatment	Assay Used	Result (Relative to Reference Control)
Camptothecin	Jurkat Cells	10 μ M	ATP-Red 1	Increased fluorescence (qualitative)
Mefloquine	P. falciparum	100 nM, 4 h	CellTiter-Glo	~2.4-fold ATP Increase
Artemisinin	P. falciparum	100 nM, 2 h	CellTiter-Glo	~4.5-fold ATP Increase

Signaling Pathways and Drug Targets

Drugs can alter cellular ATP levels primarily by targeting the two main ATP-producing pathways: glycolysis in the cytoplasm and oxidative phosphorylation (OXPHOS) in the mitochondria. **ATP-Red 1** is particularly well-suited for studying drugs that affect OXPHOS due to its mitochondrial localization.

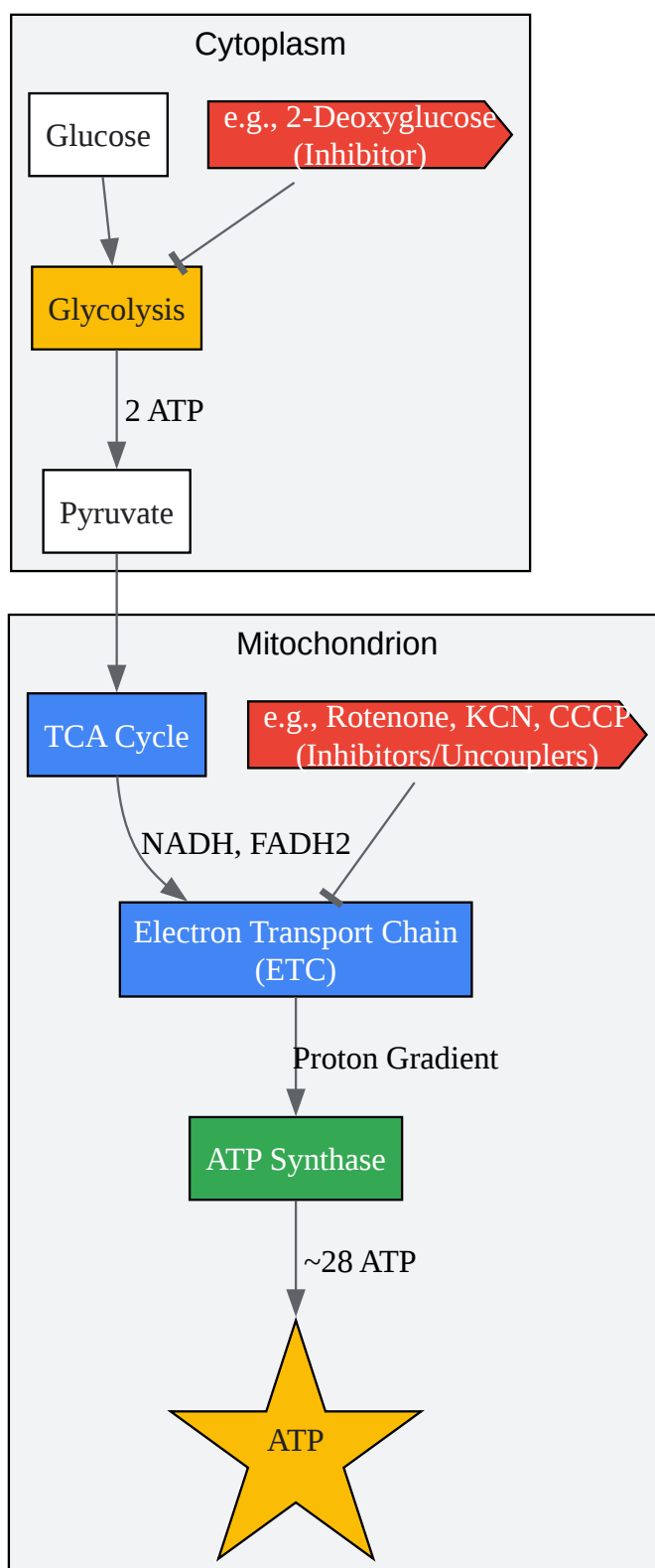

[Click to download full resolution via product page](#)

Caption: Major ATP production pathways and points of drug intervention.

Need Custom Synthesis?

BenchChem offers custom synthesis for rare earth carbides and specific isotopic labeling.

Email: info@benchchem.com or [Request Quote Online](#).

References

- 1. [sigmaaldrich.com](https://www.sigmaaldrich.com) [[sigmaaldrich.com](https://www.sigmaaldrich.com)]
- 2. Developing In Vitro Models to Define the Role of Direct Mitochondrial Toxicity in Frequently Reported Drug-Induced Rhabdomyolysis - PMC [[pmc.ncbi.nlm.nih.gov](https://pubmed.ncbi.nlm.nih.gov/)]
- 3. [researchgate.net](https://www.researchgate.net) [[researchgate.net](https://www.researchgate.net)]
- To cite this document: BenchChem. [Application Note: Investigating Drug-Induced Changes in Cellular ATP with ATP-Red 1]. BenchChem, [2025]. [Online PDF]. Available at: [<https://www.benchchem.com/product/b560525#investigating-drug-induced-changes-in-cellular-atp-with-atp-red-1>]

Disclaimer & Data Validity:

The information provided in this document is for Research Use Only (RUO) and is strictly not intended for diagnostic or therapeutic procedures. While BenchChem strives to provide accurate protocols, we make no warranties, express or implied, regarding the fitness of this product for every specific experimental setup.

Technical Support: The protocols provided are for reference purposes. Unsure if this reagent suits your experiment? [[Contact our Ph.D. Support Team for a compatibility check](#)]

Need Industrial/Bulk Grade? [Request Custom Synthesis Quote](#)

BenchChem

Our mission is to be the trusted global source of essential and advanced chemicals, empowering scientists and researchers to drive progress in science and industry.

Contact

Address: 3281 E Guasti Rd

Ontario, CA 91761, United States

Phone: (601) 213-4426

Email: info@benchchem.com