

Application Note: Establishing and Characterizing Adrixetinib-Resistant Cancer Cell Line Models

Author: BenchChem Technical Support Team. **Date:** December 2025

Compound of Interest

Compound Name: *Adrixetinib*

Cat. No.: *B10856184*

[Get Quote](#)

For Research Use Only. Not for use in diagnostic procedures.

Introduction

Adrixetinib (also known as Q702) is a potent, orally bioavailable small molecule inhibitor targeting the receptor tyrosine kinases (RTKs) Axl, Mer, and Colony-Stimulating Factor 1 Receptor (CSF1R).[1][2][3] These kinases are key players in tumor cell proliferation, survival, invasion, and immune evasion.[4][5] Overexpression and activation of Axl, Mer, and CSF1R are associated with poor prognosis and the development of resistance to various cancer therapies.[6][7][8][9] The development of in vitro models of acquired resistance to **Adrixetinib** is crucial for understanding the molecular mechanisms that drive resistance and for the development of novel therapeutic strategies to overcome it. This document provides a detailed protocol for establishing **Adrixetinib**-resistant cancer cell lines and for characterizing the resistant phenotype.

Principle

The establishment of drug-resistant cell lines is achieved through continuous exposure of a parental cancer cell line to incrementally increasing concentrations of the therapeutic agent, in this case, **Adrixetinib**. This process selects for a population of cells that can survive and proliferate at concentrations of the drug that are cytotoxic to the parental cell line. The resulting resistant cell line can then be characterized by determining its half-maximal inhibitory

concentration (IC50) for **Adrixetinib** and by analyzing changes in the expression and activation of key proteins in the Axl/Mer/CSF1R signaling pathways.

Materials and Reagents

- Parental cancer cell line of interest (e.g., A549, a human lung carcinoma cell line)
- **Adrixetinib** (Q702)
- Complete cell culture medium (e.g., RPMI-1640 supplemented with 10% Fetal Bovine Serum and 1% Penicillin-Streptomycin)
- Phosphate-Buffered Saline (PBS)
- Trypsin-EDTA
- MTT (3-(4,5-dimethylthiazol-2-yl)-2,5-diphenyltetrazolium bromide) reagent
- Dimethyl sulfoxide (DMSO)
- Lysis buffer (e.g., RIPA buffer)
- Protease and phosphatase inhibitor cocktails
- BCA Protein Assay Kit
- Primary antibodies (e.g., anti-Axl, anti-Mer, anti-CSF1R, anti-phospho-Axl, anti-phospho-Mer, anti-phospho-Akt, anti-Akt, anti-phospho-ERK1/2, anti-ERK1/2, anti-GAPDH)
- HRP-conjugated secondary antibodies
- Chemiluminescent substrate
- 96-well plates
- Cell culture flasks and dishes
- Western blotting equipment and reagents

Experimental Protocols

Part 1: Establishment of **Adrixetinib**-Resistant Cell Line

This protocol describes a stepwise method for generating a resistant cell line over several months.

- Determine the initial IC₅₀ of **Adrixetinib** for the parental cell line:
 - Plate the parental cells in 96-well plates and treat with a range of **Adrixetinib** concentrations for 72 hours.
 - Perform an MTT assay to determine cell viability and calculate the IC₅₀ value.
- Initiate continuous drug exposure:
 - Culture the parental cells in a medium containing **Adrixetinib** at a starting concentration of approximately one-tenth of the IC₅₀.
- Gradual dose escalation:
 - Once the cells have adapted and are proliferating at a normal rate, double the concentration of **Adrixetinib** in the culture medium.
 - Continue this process of dose escalation, allowing the cells to recover and resume normal proliferation at each new concentration. This process can take 6-12 months.
- Establishment of the resistant cell line:
 - The cell line is considered resistant when it can proliferate in a concentration of **Adrixetinib** that is at least 10-fold higher than the initial IC₅₀ of the parental line.
- Maintenance of the resistant cell line:
 - Continuously culture the resistant cell line in a medium containing the highest tolerated concentration of **Adrixetinib** to maintain the resistant phenotype.

Part 2: Characterization of the **Adrixetinib**-Resistant Phenotype

A. Determination of the IC₅₀ of **Adrixetinib** in Parental and Resistant Cell Lines using MTT Assay

- Seed both parental and **Adrixetinib**-resistant cells into 96-well plates at a density of 5,000 cells/well and allow them to adhere overnight.
- Treat the cells with a serial dilution of **Adrixetinib** for 72 hours.
- Add 20 µL of MTT solution (5 mg/mL in PBS) to each well and incubate for 4 hours at 37°C.
- Remove the medium and add 150 µL of DMSO to each well to dissolve the formazan crystals.
- Measure the absorbance at 570 nm using a microplate reader.
- Calculate the IC₅₀ values for both cell lines and determine the resistance factor (RF) using the formula: $RF = IC_{50} (\text{Resistant Line}) / IC_{50} (\text{Parental Line})$.

B. Analysis of Protein Expression by Western Blotting

- Culture parental and **Adrixetinib**-resistant cells to 80-90% confluency.
- Lyse the cells in lysis buffer containing protease and phosphatase inhibitors.
- Determine the protein concentration of the lysates using a BCA protein assay.
- Separate equal amounts of protein (20-30 µg) by SDS-PAGE and transfer to a PVDF membrane.
- Block the membrane with 5% non-fat milk in TBST for 1 hour at room temperature.
- Incubate the membrane with primary antibodies against Axl, Mer, CSF1R, and downstream signaling proteins overnight at 4°C.

- Wash the membrane and incubate with the appropriate HRP-conjugated secondary antibody for 1 hour at room temperature.
- Detect the protein bands using a chemiluminescent substrate and an imaging system.
- Quantify the band intensities and normalize to a loading control like GAPDH.

Data Presentation

Illustrative data is provided below to demonstrate expected results.

Table 1: **Adrixetinib** IC50 Values in Parental and Resistant Cell Lines. This table summarizes the half-maximal inhibitory concentration (IC50) of **Adrixetinib** in the parental and the established resistant cell line. The resistance factor indicates the magnitude of acquired resistance.

Cell Line	Adrixetinib IC50 (nM)	Resistance Factor (Fold Change)
Parental	50	-
Adrixetinib-Resistant	750	15

Table 2: Relative Protein Expression in **Adrixetinib**-Resistant Cells. This table shows the illustrative fold change in the expression of key proteins in the **Adrixetinib**-resistant cell line compared to the parental cell line, as determined by Western blot analysis.

Protein	Fold Change in Expression (Resistant vs. Parental)
Axl	3.5
Phospho-Axl	4.2
Mer	1.2
Phospho-Mer	1.5
CSF1R	1.1
Phospho-Akt	2.8
Phospho-ERK1/2	2.5

Mandatory Visualizations

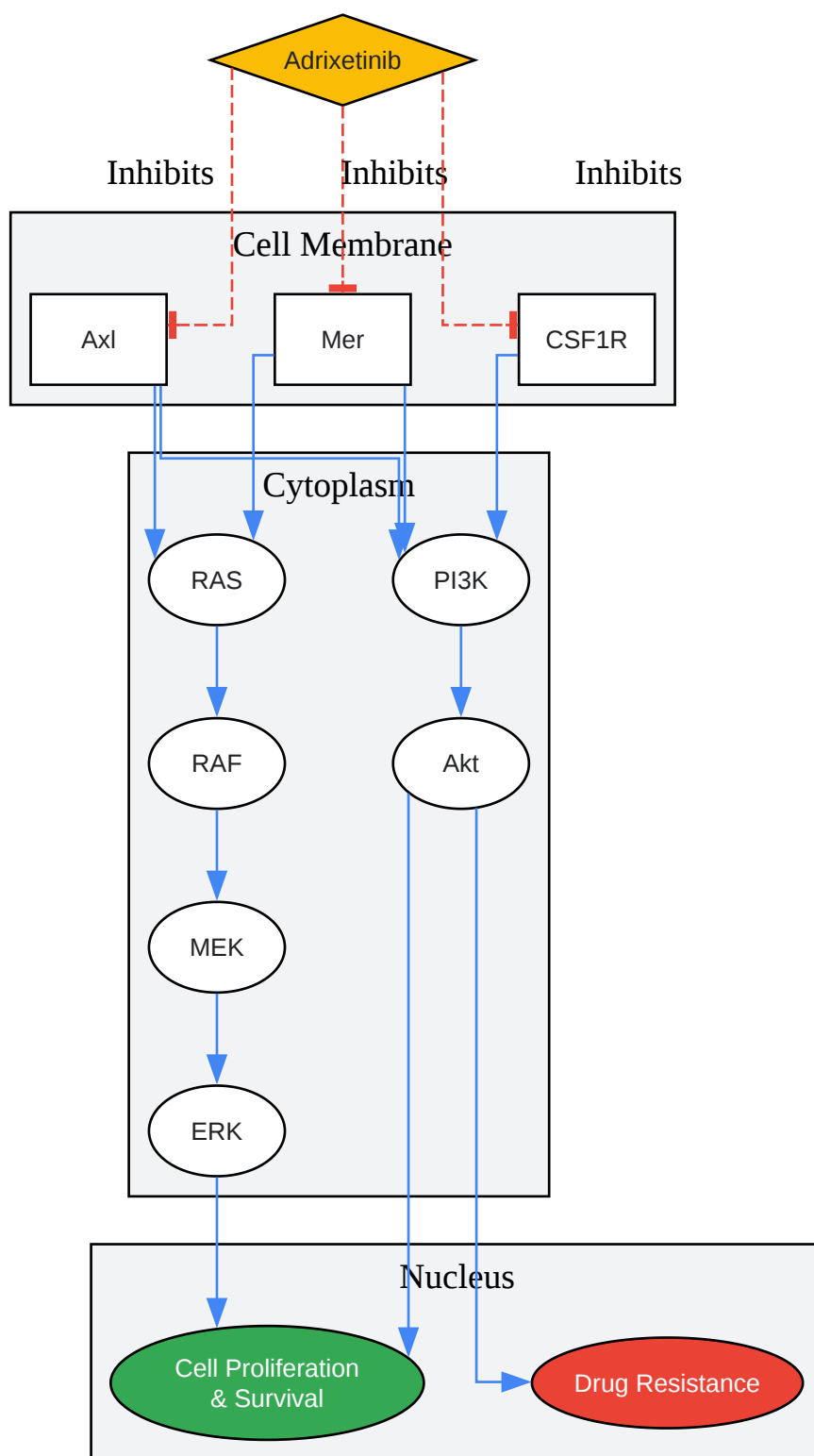

[Click to download full resolution via product page](#)

Caption: **Adrixetinib** Signaling Pathway Inhibition.

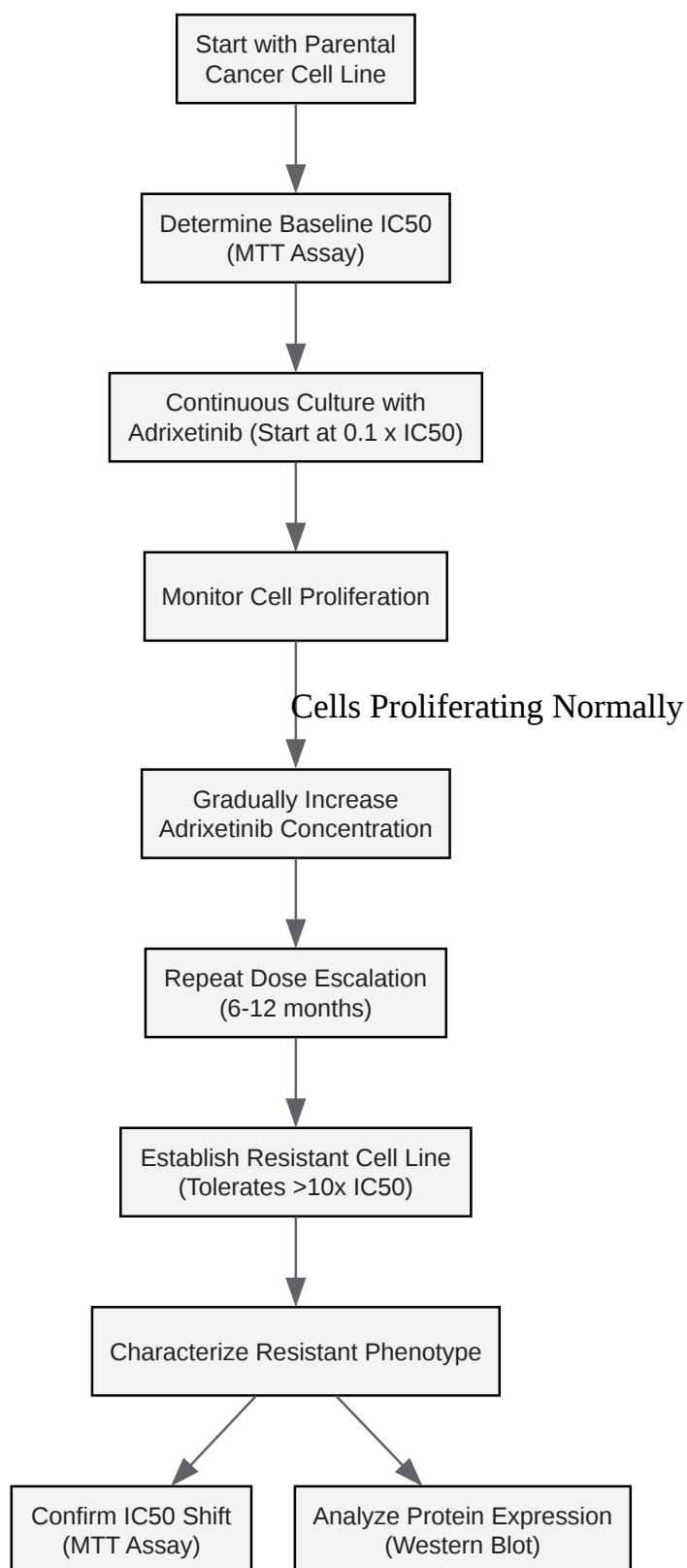

[Click to download full resolution via product page](#)

Caption: Workflow for Establishing Resistant Cell Lines.

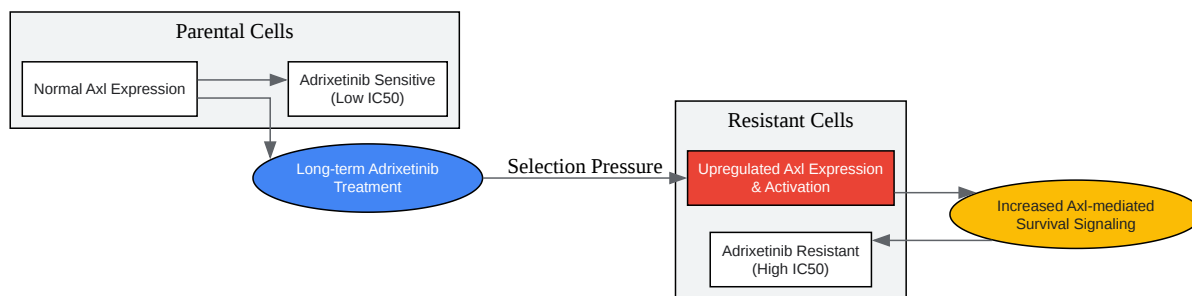

[Click to download full resolution via product page](#)

Caption: Logical Relationship of Resistance Development.

Troubleshooting

Issue	Possible Cause	Solution
Cells do not adapt to increased drug concentration	The incremental increase in drug concentration is too high.	Reduce the fold-increase in drug concentration at each step.
High background in Western blot	Insufficient blocking or washing.	Increase blocking time and/or the number and duration of washes.
Inconsistent MTT assay results	Variation in cell seeding density.	Ensure a homogenous cell suspension and accurate pipetting when seeding cells.
Loss of resistant phenotype over time	Discontinuation of drug in the culture medium.	Maintain the resistant cell line in a medium containing a maintenance dose of Adrixetinib.

Conclusion

The protocols outlined in this application note provide a robust framework for the generation and characterization of **Adrixetinib**-resistant cancer cell line models. These models are invaluable tools for investigating the molecular underpinnings of drug resistance and for the preclinical evaluation of novel therapeutic strategies aimed at overcoming resistance to Axl/Mer/CSF1R inhibition.

Need Custom Synthesis?

BenchChem offers custom synthesis for rare earth carbides and specific isotopic labeling.

Email: info@benchchem.com or [Request Quote Online](#).

References

- 1. Mer receptor tyrosine kinase is frequently overexpressed in human non-small cell lung cancer, confirming resistance to erlotinib - PMC [[pmc.ncbi.nlm.nih.gov](https://pubmed.ncbi.nlm.nih.gov/)]
- 2. oncotarget.com [oncotarget.com]
- 3. Quantitative Prediction of Fold Resistance for Inhibitors of EGFR - PMC [[pmc.ncbi.nlm.nih.gov](https://pubmed.ncbi.nlm.nih.gov/)]
- 4. Mer or Axl Receptor Tyrosine Kinase Inhibition Promotes Apoptosis, Blocks Growth, and Enhances Chemosensitivity of Human Non-Small Cell Lung Cancer - PMC [[pmc.ncbi.nlm.nih.gov](https://pubmed.ncbi.nlm.nih.gov/)]
- 5. Targeting the CSF1/CSF1R signaling pathway: an innovative strategy for ultrasound combined with macrophage exhaustion in pancreatic cancer therapy - PMC [[pmc.ncbi.nlm.nih.gov](https://pubmed.ncbi.nlm.nih.gov/)]
- 6. Axl receptor tyrosine kinase is up-regulated in metformin resistant prostate cancer cells - PMC [[pmc.ncbi.nlm.nih.gov](https://pubmed.ncbi.nlm.nih.gov/)]
- 7. CSF-1R in Cancer: More than a Myeloid Cell Receptor - PMC [[pmc.ncbi.nlm.nih.gov](https://pubmed.ncbi.nlm.nih.gov/)]
- 8. AXL in cancer: a modulator of drug resistance and therapeutic target - PMC [[pmc.ncbi.nlm.nih.gov](https://pubmed.ncbi.nlm.nih.gov/)]
- 9. aacrjournals.org [aacrjournals.org]
- To cite this document: BenchChem. [Application Note: Establishing and Characterizing Adrixetinib-Resistant Cancer Cell Line Models]. BenchChem, [2025]. [Online PDF]. Available at: [<https://www.benchchem.com/product/b10856184#establishing-adrixetinib-resistant-cell-line-models>]

Disclaimer & Data Validity:

The information provided in this document is for Research Use Only (RUO) and is strictly not intended for diagnostic or therapeutic procedures. While BenchChem strives to provide accurate protocols, we make no warranties, express or implied, regarding the fitness of this product for every specific experimental setup.

Technical Support: The protocols provided are for reference purposes. Unsure if this reagent suits your experiment? [[Contact our Ph.D. Support Team for a compatibility check](#)]

Need Industrial/Bulk Grade? [Request Custom Synthesis Quote](#)

BenchChem

Our mission is to be the trusted global source of essential and advanced chemicals, empowering scientists and researchers to drive progress in science and industry.

Contact

Address: 3281 E Guasti Rd

Ontario, CA 91761, United States

Phone: (601) 213-4426

Email: info@benchchem.com