

"Anti-inflammatory agent 35" minimizing cytotoxicity in cell lines

Author: BenchChem Technical Support Team. **Date:** December 2025

Compound of Interest

Compound Name: *Anti-inflammatory agent 35*

Cat. No.: *B10854967*

[Get Quote](#)

Technical Support Center: Anti-inflammatory Agent 35

This technical support center provides troubleshooting guides and frequently asked questions (FAQs) for researchers utilizing **Anti-inflammatory Agent 35** (also known as compound 5a27), an orally active curcumin analogue. This agent is recognized for its anti-inflammatory properties, which are mediated through the inhibition of the Mitogen-Activated Protein Kinase (MAPK) and Nuclear Factor-kappa B (NF- κ B) signaling pathways. A key feature of this compound is its ability to inhibit the production of pro-inflammatory cytokines, such as Interleukin-6 (IL-6) and Tumor Necrosis Factor-alpha (TNF- α), with minimal cytotoxicity in specific cell lines.[1]

Frequently Asked Questions (FAQs)

Q1: What is the mechanism of action of **Anti-inflammatory Agent 35**?

A1: **Anti-inflammatory Agent 35** functions by blocking the MAPK signaling pathway and inhibiting the nuclear translocation of the p65 subunit of NF- κ B.[1] This dual inhibition leads to a downstream reduction in the production of pro-inflammatory cytokines.

Q2: At what concentration is **Anti-inflammatory Agent 35** effective without causing cytotoxicity?

A2: Studies have shown that **Anti-inflammatory Agent 35** effectively inhibits the production of pro-inflammatory cytokines at a concentration of 10 μM without inducing cytotoxicity in mouse primary macrophages and RAW 264.7 mouse macrophage cell lines.[1]

Q3: What are the IC50 values for the inhibition of IL-6 and TNF- α production by **Anti-inflammatory Agent 35**?

A3: In mouse primary macrophages, the IC50 values for the inhibition of IL-6 and TNF- α production are 2.23 μM and 2.40 μM , respectively.[1]

Data Presentation: Cytotoxicity of Curcumin Analogues

While specific cytotoxicity data for **Anti-inflammatory Agent 35** across a wide range of cell lines is not readily available in the public domain, the following tables summarize the cytotoxic effects (IC50 values) of other novel curcumin analogues on various cancer cell lines. This data is provided to offer a comparative perspective on the potential cytotoxicity of this class of compounds.

Table 1: Cytotoxicity (IC50, μM) of Asymmetrical Mono-Carbonyl Analogs of Curcumin (AMACs)

Compound	HeLa (Cervical Cancer)	MCF7 (Breast Cancer)	Vero (Normal Kidney Cells)
1b	40.65 - 95.55	7.86	3.94 - 16.15
1c	40.65 - 95.55	7.86 - 35.88	3.94 - 16.15
1d	40.65 - 95.55	7.86 - 35.88	3.94 - 16.15
1e	40.65 - 95.55	7.86 - 35.88	3.94 - 16.15
2a	40.65 - 95.55	Not Tested	3.94 - 7.28
2b	40.65 - 95.55	Not Tested	3.94 - 7.28
2c	40.65 - 95.55	Not Tested	3.94 - 7.28
2d	40.65 - 95.55	Not Tested	3.94 - 7.28
2e	40.65 - 95.55	7.86 - 35.88	Not Tested
Cisplatin (Control)	67.59	12.85	-
Curcumin (Control)	-	10.47	-

Source: Synthesis and Cytotoxicity Evaluation of Novel Asymmetrical Mono-Carbonyl Analogs of Curcumin (AMACs) against Vero, HeLa, and MCF7 Cell Lines.[2]

Table 2: Cytotoxicity (IC50, μ M) of Monocarbonyl Analogs of Curcumin

Compound	U2-OS (Osteosarcoma)	OS-732 (Osteosarcoma)	A549 (Lung Cancer)	HepG2 (Liver Cancer)	P815 (Mastocytoma)	PC-3 (Prostate Cancer)	HeLa (Cervical Cancer)
A111	2.84	8.17	>20	>20	3.26	2.23	>20
A113	6.91	8.15	>20	>20	>20	>20	>20
B114	7.24	9.23	10.86	15.32	0.84	4.12	3.23
Curcumin	9.94	11.6	13.97	>20	10.33	15.0	17.5

Source: Synthesis and Cytotoxic Evaluation of Monocarbonyl Analogs of Curcumin as Potential Anti-Tumor Agents.[3]

Experimental Protocols

1. Cell Viability/Cytotoxicity Assay (MTT Assay)

This protocol is a general guideline for assessing the effect of **Anti-inflammatory Agent 35** on cell viability.

- Materials:
 - Target cell line(s)
 - Complete culture medium
 - **Anti-inflammatory Agent 35** (dissolved in a suitable solvent, e.g., DMSO)
 - MTT (3-(4,5-dimethylthiazol-2-yl)-2,5-diphenyltetrazolium bromide) solution (5 mg/mL in PBS)
 - Solubilization buffer (e.g., DMSO or a solution of 10% SDS in 0.01 M HCl)
 - 96-well plates
 - Microplate reader
- Procedure:
 - Seed cells in a 96-well plate at a predetermined optimal density and incubate for 24 hours to allow for attachment.
 - Prepare serial dilutions of **Anti-inflammatory Agent 35** in complete culture medium.
 - Remove the existing medium from the wells and replace it with the medium containing different concentrations of the compound. Include a vehicle control (medium with the same concentration of solvent used to dissolve the compound) and a no-treatment control.

- Incubate the plate for the desired exposure time (e.g., 24, 48, or 72 hours).
- Add 10-20 μL of MTT solution to each well and incubate for 2-4 hours at 37°C, allowing for the formation of formazan crystals.
- Carefully remove the medium and add 100-200 μL of solubilization buffer to each well to dissolve the formazan crystals.
- Measure the absorbance at a wavelength of 570 nm using a microplate reader.
- Calculate cell viability as a percentage of the no-treatment control.

2. Measurement of IL-6 and TNF- α Production (ELISA)

This protocol outlines the general steps for quantifying cytokine levels in cell culture supernatants.

- Materials:
 - Cell culture supernatant from cells treated with **Anti-inflammatory Agent 35** and a pro-inflammatory stimulus (e.g., LPS).
 - Commercial ELISA kits for IL-6 and TNF- α .
 - Microplate reader.
- Procedure:
 - Culture cells (e.g., RAW 264.7 macrophages) and pre-treat with various concentrations of **Anti-inflammatory Agent 35** for a specified time (e.g., 1 hour).
 - Stimulate the cells with a pro-inflammatory agent like Lipopolysaccharide (LPS) for a designated period (e.g., 24 hours).
 - Collect the cell culture supernatants and centrifuge to remove any cellular debris.
 - Perform the ELISA for IL-6 and TNF- α according to the manufacturer's instructions provided with the kit.

- Measure the absorbance using a microplate reader at the recommended wavelength.
- Calculate the concentration of each cytokine by comparing the sample absorbance to the standard curve generated.

3. Assessment of MAPK and NF- κ B Signaling (Western Blot)

This protocol provides a general workflow for analyzing the phosphorylation status of MAPK pathway proteins and the nuclear translocation of NF- κ B p65.

- Materials:
 - Cell lysates from cells treated with **Anti-inflammatory Agent 35** and a pro-inflammatory stimulus.
 - Protein extraction buffers (cytoplasmic and nuclear).
 - SDS-PAGE gels and electrophoresis equipment.
 - Transfer apparatus and membranes (e.g., PVDF or nitrocellulose).
 - Blocking buffer (e.g., 5% non-fat milk or BSA in TBST).
 - Primary antibodies specific for phosphorylated and total forms of p38, ERK, and NF- κ B p65.
 - HRP-conjugated secondary antibodies.
 - Chemiluminescent substrate.
 - Imaging system.
- Procedure:
 - Treat cells with **Anti-inflammatory Agent 35** and/or a pro-inflammatory stimulus for the appropriate duration.

- Lyse the cells to extract total protein or perform subcellular fractionation to obtain cytoplasmic and nuclear extracts.
- Determine the protein concentration of each lysate.
- Separate the proteins by SDS-PAGE and transfer them to a membrane.
- Block the membrane with blocking buffer for at least 1 hour at room temperature.
- Incubate the membrane with the primary antibody overnight at 4°C.
- Wash the membrane with TBST.
- Incubate the membrane with the HRP-conjugated secondary antibody for 1 hour at room temperature.
- Wash the membrane again with TBST.
- Add the chemiluminescent substrate and visualize the protein bands using an imaging system.

Troubleshooting Guides

Troubleshooting for Cytotoxicity Assays

Issue	Possible Cause	Suggested Solution
High background absorbance in control wells	- Contamination of media or reagents.- High cell density.	- Use fresh, sterile reagents.- Optimize cell seeding density.
Low signal or poor dose-response	- Insufficient incubation time.- Compound is not cytotoxic at the tested concentrations.- Cell line is resistant to the compound.	- Increase the incubation time.- Test a wider range of concentrations.- Use a different cell line.
High variability between replicate wells	- Uneven cell seeding.- Pipetting errors.	- Ensure proper cell suspension mixing before seeding.- Use calibrated pipettes and be consistent with technique.

Troubleshooting for ELISA

Issue	Possible Cause	Suggested Solution
No or weak signal	- Incorrect antibody concentration.- Inactive reagents.- Insufficient incubation times.	- Optimize antibody dilutions.- Use fresh or properly stored reagents.- Follow the recommended incubation periods.
High background	- Insufficient washing.- Cross-reactivity of antibodies.- High concentration of detection reagent.	- Increase the number and vigor of wash steps.- Use highly specific antibodies.- Optimize the concentration of the detection reagent.
High coefficient of variation (CV%)	- Pipetting errors.- Inconsistent incubation times or temperatures.	- Ensure accurate and consistent pipetting.- Maintain uniform incubation conditions for all wells.

Troubleshooting for Western Blot

Issue	Possible Cause	Suggested Solution
No or weak signal	- Low protein concentration. - Inefficient antibody binding. - Inactive secondary antibody or substrate.	- Load more protein. - Optimize primary antibody concentration and incubation time. - Use fresh reagents.
High background or non-specific bands	- Too high primary or secondary antibody concentration. - Insufficient blocking. - Inadequate washing.	- Titrate antibody concentrations. - Increase blocking time or use a different blocking agent. - Increase the duration and number of wash steps.
Uneven bands ("smiling")	- Uneven heat distribution during electrophoresis.	- Run the gel at a lower voltage or in a cold room.

Visualizations

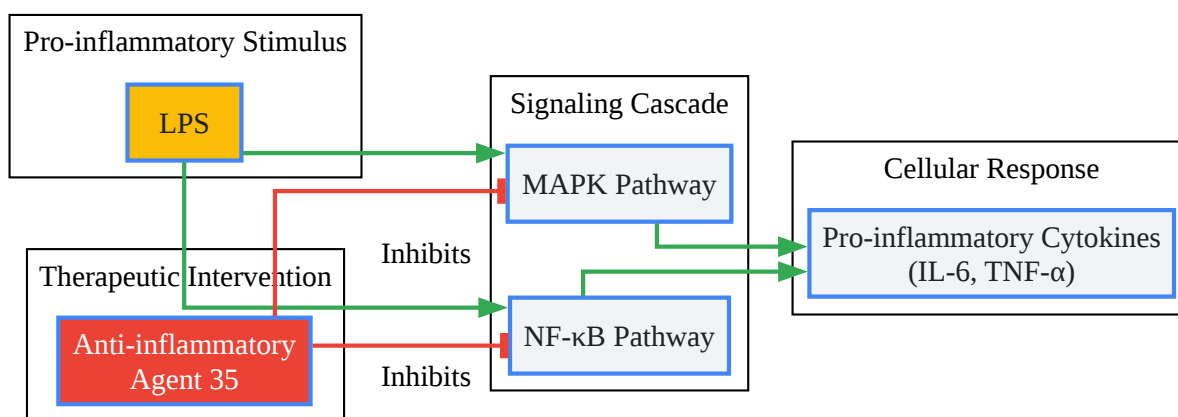

[Click to download full resolution via product page](#)

Caption: Inhibition of MAPK and NF-κB pathways by Agent 35.

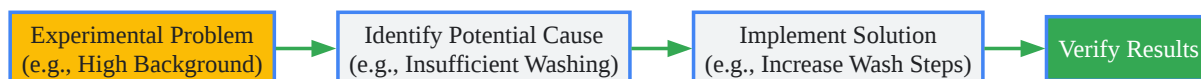
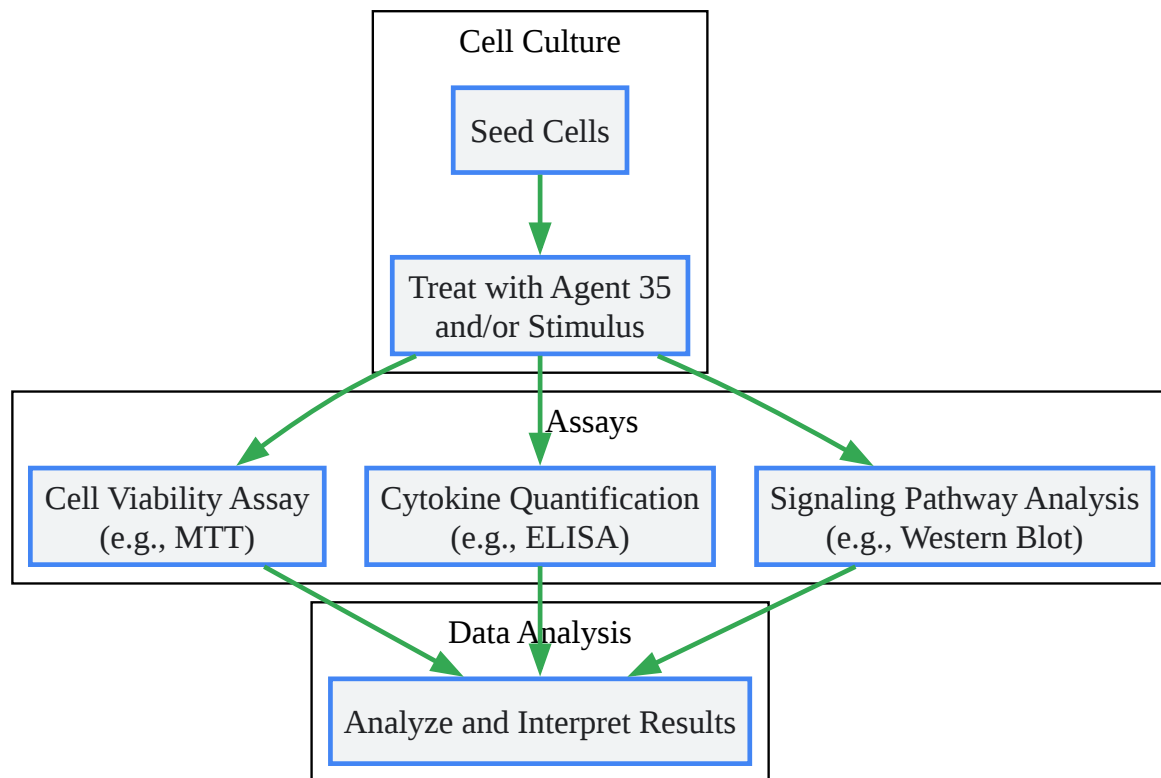

[Click to download full resolution via product page](#)

Need Custom Synthesis?

BenchChem offers custom synthesis for rare earth carbides and specific isotopic labeling.

Email: info@benchchem.com or [Request Quote Online](#).

References

- 1. wcrj.net [wcrj.net]
- 2. mdpi.com [mdpi.com]

- 3. Synthesis and Cytotoxic Evaluation of Monocarbonyl Analogs of Curcumin as Potential Anti-Tumor Agents - PMC [pmc.ncbi.nlm.nih.gov]
- To cite this document: BenchChem. ["Anti-inflammatory agent 35" minimizing cytotoxicity in cell lines]. BenchChem, [2025]. [Online PDF]. Available at: [https://www.benchchem.com/product/b10854967#anti-inflammatory-agent-35-minimizing-cytotoxicity-in-cell-lines]

Disclaimer & Data Validity:

The information provided in this document is for Research Use Only (RUO) and is strictly not intended for diagnostic or therapeutic procedures. While BenchChem strives to provide accurate protocols, we make no warranties, express or implied, regarding the fitness of this product for every specific experimental setup.

Technical Support: The protocols provided are for reference purposes. Unsure if this reagent suits your experiment? [[Contact our Ph.D. Support Team for a compatibility check](#)]

Need Industrial/Bulk Grade? [Request Custom Synthesis Quote](#)

BenchChem

Our mission is to be the trusted global source of essential and advanced chemicals, empowering scientists and researchers to drive progress in science and industry.

Contact

Address: 3281 E Guasti Rd

Ontario, CA 91761, United States

Phone: (601) 213-4426

Email: info@benchchem.com