

Ano1-IN-2 batch-to-batch variability

Author: BenchChem Technical Support Team. **Date:** December 2025

Compound of Interest

Compound Name: *Ano1-IN-2*

Cat. No.: *B15141482*

[Get Quote](#)

Technical Support Center: Ano1-IN-2

Welcome to the technical support center for **Ano1-IN-2**. This resource is designed for researchers, scientists, and drug development professionals to provide troubleshooting guidance and frequently asked questions (FAQs) regarding the use of **Ano1-IN-2** in experimental settings.

Frequently Asked Questions (FAQs)

Q1: What is **Ano1-IN-2** and what is its mechanism of action?

Ano1-IN-2 is a selective inhibitor of the Anoctamin-1 (ANO1) channel, also known as Transmembrane member 16A (TMEM16A).[1][2] ANO1 is a calcium-activated chloride channel (CaCC) that plays a crucial role in various physiological processes, including epithelial secretion, smooth muscle contraction, and neuronal excitability.[3][4][5] Dysregulation of ANO1 has been implicated in several diseases, including cancer, asthma, and hypertension. **Ano1-IN-2** exerts its effect by blocking the ANO1 channel, thereby inhibiting the flow of chloride ions across the cell membrane.

Q2: What are the reported IC50 values for **Ano1-IN-2**?

Ano1-IN-2 is a selective inhibitor of the ANO1 channel with a reported IC50 of 1.75 μM . It also shows some activity against the related channel ANO2, with a reported IC50 of 7.43 μM .

Q3: My **Ano1-IN-2** solution has changed color. What should I do?

A change in the color of your **Ano1-IN-2** solution may indicate chemical degradation or oxidation. This can be caused by exposure to light, air, or impurities in the solvent. It is recommended to discard the solution and prepare a fresh stock from a new aliquot of the compound to ensure the integrity of your experiments.

Q4: I'm observing precipitation in my frozen stock solution of **Ano1-IN-2** after thawing. How can I prevent this?

Precipitation upon thawing can occur if the compound's solubility limit is exceeded at lower temperatures. To prevent this, consider the following:

- **Thawing Protocol:** Thaw the solution slowly at room temperature and vortex gently to ensure it is fully dissolved before use.
- **Storage Concentration:** Storing the compound at a very high concentration can increase the likelihood of precipitation. Consider preparing and storing stock solutions at a slightly lower concentration.
- **Avoid Repeated Freeze-Thaw Cycles:** Aliquot your stock solution into smaller, single-use volumes to minimize the number of freeze-thaw cycles.

Troubleshooting Guide: Batch-to-Batch Variability

While specific reports on **Ano1-IN-2** batch-to-batch variability are not widely documented, it is a potential issue for any small molecule inhibitor. Inconsistent experimental results between different lots of **Ano1-IN-2** may be attributable to variations in purity, isomeric ratio, or the presence of trace impurities.

Issue: Inconsistent IC50 values or unexpected biological effects between different batches of **Ano1-IN-2**.

This is a critical issue that can compromise the reproducibility of your research. The following steps provide a systematic approach to investigate and mitigate potential batch-to-batch variability.

Step 1: Initial Compound Verification

Before starting your experiments, it is crucial to verify the quality of each new batch of **Ano1-IN-2**.

Experimental Protocol: Quality Control Checks

- Request Certificate of Analysis (CoA): Always obtain the CoA from the supplier for each new batch. This document should provide information on the compound's identity, purity (typically determined by HPLC and/or NMR), and other quality control parameters.
- Analytical Validation (Optional but Recommended): If you have access to analytical chemistry facilities, consider performing your own in-house validation.
 - High-Performance Liquid Chromatography (HPLC): To confirm the purity of the compound and identify any potential impurities.
 - Mass Spectrometry (MS): To confirm the molecular weight of the compound.
 - Nuclear Magnetic Resonance (NMR) Spectroscopy: To confirm the chemical structure of the compound.

Step 2: Functional Assay Validation

Once the chemical integrity of the new batch is confirmed, it is essential to validate its biological activity in a standardized functional assay.

Experimental Protocol: Standardized IC50 Determination

- Cell Line: Use a consistent cell line that endogenously expresses ANO1 or a well-characterized recombinant cell line.
- Assay Conditions: Keep all assay parameters constant, including cell density, incubation time, temperature, and the concentration of the ANO1 activator (e.g., a calcium ionophore like ionomycin).
- Dose-Response Curve: Perform a full dose-response curve with the new batch of **Ano1-IN-2** and compare it to the dose-response curve of a previously validated batch.

- **Data Analysis:** Calculate the IC50 value for the new batch and compare it to the expected value and the value obtained from your reference batch. A significant deviation may indicate a difference in potency.

Data Presentation: Comparing Ano1-IN-2 Batches

Parameter	Batch A (Reference)	Batch B (New)	Acceptance Criteria
Purity (HPLC)	99.5%	98.9%	>98%
Molecular Weight (MS)	Confirmed	Confirmed	Matches expected MW
IC50 (Functional Assay)	1.8 μ M	2.5 μ M	Within 2-fold of reference

Step 3: Troubleshooting Inconsistent Results

If you observe significant variability between batches, consider the following troubleshooting steps.

Issue: New batch of **Ano1-IN-2** is less potent.

- **Possible Cause:** Lower purity or the presence of inactive isomers.
- **Troubleshooting:**
 - Review the CoA and any in-house analytical data for purity discrepancies.
 - If possible, obtain a new batch from the supplier and repeat the validation.
 - Adjust the concentration used in your experiments based on the new, validated IC50 value, but be cautious as higher concentrations may lead to off-target effects.

Issue: New batch of **Ano1-IN-2** shows unexpected off-target effects or cellular toxicity.

- **Possible Cause:** Presence of cytotoxic impurities.
- **Troubleshooting:**

- Examine the HPLC or NMR data for the presence of unknown peaks that might represent impurities.
- Test the inhibitor in a counterscreen using a cell line that does not express ANO1 to determine if the observed effects are independent of ANO1 inhibition.
- Lower the concentration of the inhibitor to the minimum required for on-target inhibition to minimize off-target effects.

Visualizing Key Concepts

To further aid in understanding the context of **Ano1-IN-2** experiments, the following diagrams illustrate the relevant signaling pathway, a general experimental workflow, and a logical approach to troubleshooting.

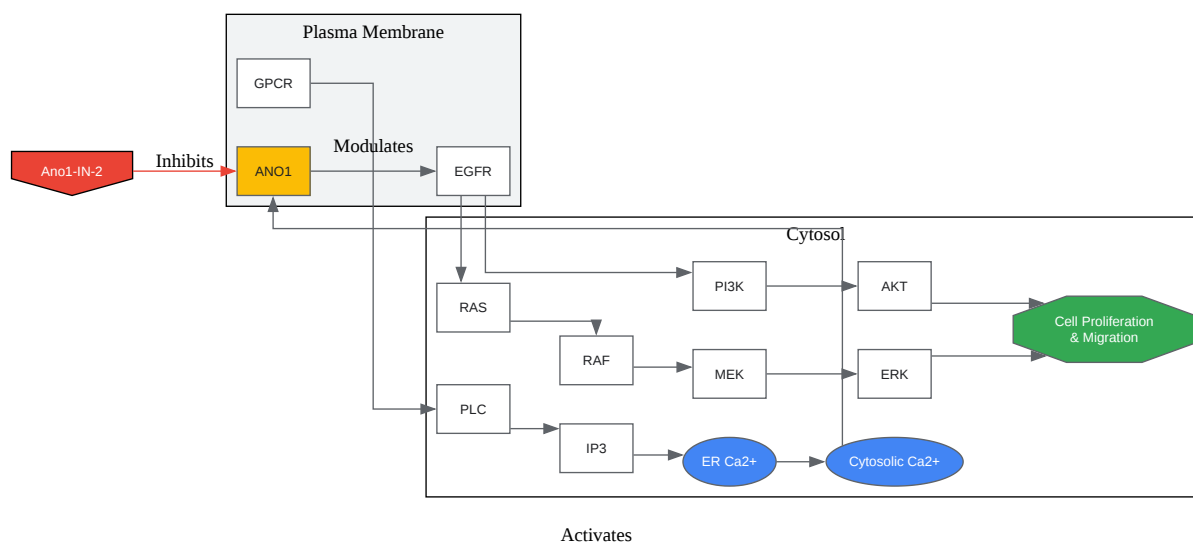

[Click to download full resolution via product page](#)

Caption: ANO1 Signaling Pathway and Point of Inhibition by **Ano1-IN-2**.

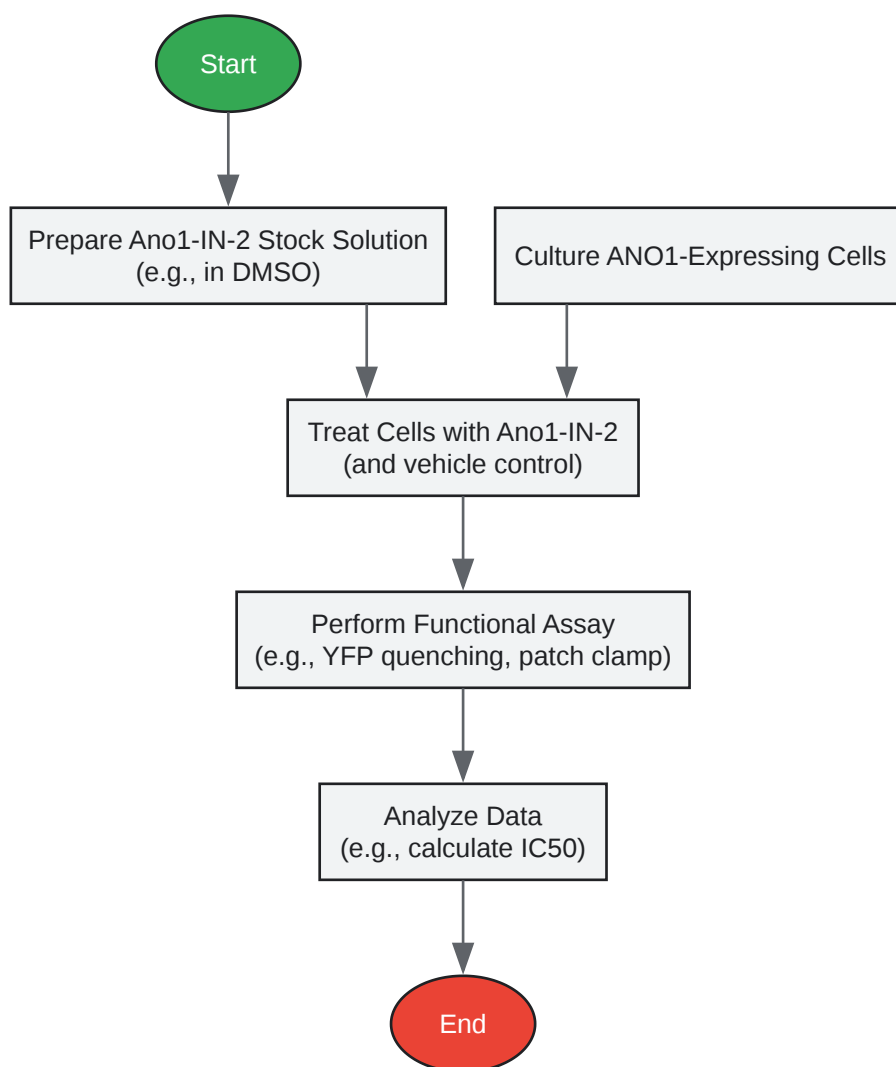

[Click to download full resolution via product page](#)

Caption: General Experimental Workflow for Testing **Ano1-IN-2** Activity.

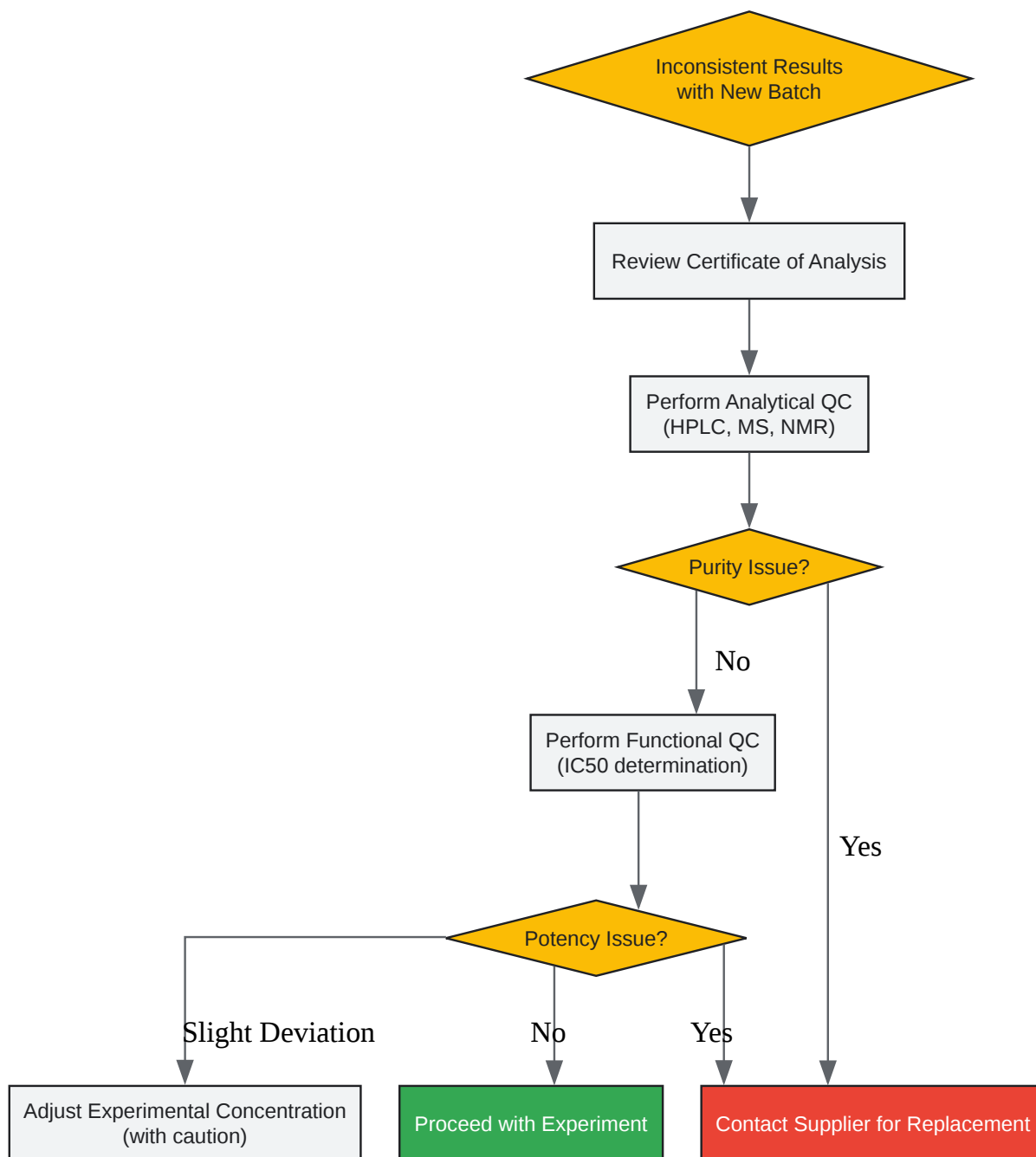

[Click to download full resolution via product page](#)

Need Custom Synthesis?

BenchChem offers custom synthesis for rare earth carbides and specific isotopic labeling.

Email: info@benchchem.com or [Request Quote Online](#).

References

- 1. medchemexpress.com [medchemexpress.com]
- 2. What are ANO1 inhibitors and how do they work? [synapse.patsnap.com]
- 3. ANO1: central role and clinical significance in non-neoplastic and neoplastic diseases - PMC [pmc.ncbi.nlm.nih.gov]
- 4. Frontiers | Calcium-Activated Chloride Channel ANO1/TMEM16A: Regulation of Expression and Signaling [frontiersin.org]
- 5. Calcium-Activated Chloride Channel ANO1/TMEM16A: Regulation of Expression and Signaling - PMC [pmc.ncbi.nlm.nih.gov]
- To cite this document: BenchChem. [Ano1-IN-2 batch-to-batch variability]. BenchChem, [2025]. [Online PDF]. Available at: [https://www.benchchem.com/product/b15141482#ano1-in-2-batch-to-batch-variability]

Disclaimer & Data Validity:

The information provided in this document is for Research Use Only (RUO) and is strictly not intended for diagnostic or therapeutic procedures. While BenchChem strives to provide accurate protocols, we make no warranties, express or implied, regarding the fitness of this product for every specific experimental setup.

Technical Support: The protocols provided are for reference purposes. Unsure if this reagent suits your experiment? [[Contact our Ph.D. Support Team for a compatibility check](#)]

Need Industrial/Bulk Grade? [Request Custom Synthesis Quote](#)

BenchChem

Our mission is to be the trusted global source of essential and advanced chemicals, empowering scientists and researchers to drive progress in science and industry.

Contact

Address: 3281 E Guasti Rd
Ontario, CA 91761, United States
Phone: (601) 213-4426
Email: info@benchchem.com