

# An In-depth Technical Guide to Bioconjugation with Fluorescent Dyes

**Author:** BenchChem Technical Support Team. **Date:** December 2025

## Compound of Interest

Compound Name: *5-Carboxyrhodamine 110 NHS*

*Ester*

Cat. No.: *B8116030*

[Get Quote](#)

For Researchers, Scientists, and Drug Development Professionals

## Introduction

Bioconjugation, the covalent attachment of a molecule to a biomolecule, is a cornerstone of modern life sciences research and therapeutic development. The specific labeling of proteins, nucleic acids, and other biological macromolecules with fluorescent dyes has revolutionized our ability to visualize, track, and quantify biological processes in real-time. This in-depth technical guide provides a comprehensive overview of the core principles, key chemistries, experimental protocols, and critical considerations for successful bioconjugation with fluorescent dyes.

## Core Principles of Bioconjugation Chemistry

The foundation of bioconjugation lies in the selective reaction between a reactive functional group on the fluorescent dye and a specific functional group on the biomolecule. The ideal bioconjugation chemistry is highly efficient, specific, and proceeds under mild conditions to preserve the biological activity of the target molecule. Three major classes of reactions dominate the landscape of fluorescent labeling: amine-reactive, thiol-reactive, and bioorthogonal "click" chemistries.

## Amine-Reactive Chemistry: Targeting Lysine Residues and the N-terminus

The most common strategy for labeling proteins is to target primary amines found on the side chain of lysine residues and the N-terminus of the polypeptide chain. N-hydroxysuccinimide (NHS) esters are the most prevalent amine-reactive reagents. The reaction involves the nucleophilic attack of the unprotonated primary amine on the NHS ester, resulting in the formation of a stable amide bond.[1] This reaction is most efficient at a slightly alkaline pH (7.2-8.5), where the primary amines are deprotonated and thus more nucleophilic.[2]

## Thiol-Reactive Chemistry: Site-Specific Labeling of Cysteine Residues

For more site-specific labeling, thiol-reactive chemistries targeting the sulfhydryl group of cysteine residues are employed. Maleimides are the most popular class of thiol-reactive reagents. The reaction, a Michael addition, occurs between the maleimide and the thiol group, forming a stable thioether bond.[3][4][5] This reaction is highly selective for thiols, especially within a pH range of 6.5-7.5, where the reaction with thiols is significantly faster than with other nucleophiles like amines.[6]

## Bioorthogonal "Click" Chemistry: High Efficiency and Specificity

"Click" chemistry refers to a class of reactions that are highly efficient, selective, and biocompatible.[7][8] The most prominent example in bioconjugation is the copper(I)-catalyzed azide-alkyne cycloaddition (CuAAC), which forms a stable triazole linkage.[9][10][11] A significant advantage of click chemistry is its bioorthogonality; the azide and alkyne functional groups are absent in most biological systems, preventing side reactions.[9] Strain-promoted azide-alkyne cycloaddition (SPAAC) is a variation that does not require a copper catalyst, making it particularly suitable for live-cell imaging.[7][8][12]

## Quantitative Data Presentation

### Table 1: Photophysical Properties of Common Fluorescent Dyes

Fluorescent Dye	Excitation Max (nm)	Emission Max (nm)	Extinction Coefficient (cm <sup>-1</sup> M <sup>-1</sup> )	Quantum Yield (Φ)
FITC	494	518	~75,000	0.92
TRITC	550	570	~90,000	0.95
Alexa Fluor 488	495	519	73,000	0.92
Alexa Fluor 555	555	565	155,000	0.10
Alexa Fluor 594	590	617	92,000	0.66
Alexa Fluor 647	650	668	270,000	0.33
Cy3	550	570	150,000	0.15
Cy5	649	670	250,000	0.28
Cy7	750	773	250,000	0.12

Data compiled from multiple sources.<sup>[1][13][14][15][16][17][18]</sup> Values can vary depending on the conjugation partner and solvent conditions.

## Table 2: Comparison of Bioconjugation Chemistries

Chemistry	Target Functional Group	Typical Efficiency/Yield	Bond Stability	Reaction Speed	Key Considerations
NHS Ester	Primary Amines (-NH <sub>2</sub> )	Modest to High (50-90%)[2]	High (Amide bond)	Moderate (30 min - 4 hours)	pH-sensitive (optimal ~7.2-8.5); susceptible to hydrolysis.[1]
Maleimide	Thiols (-SH)	High (>90%)[19]	High (Thioether bond)	Fast (1-2 hours)	pH-sensitive (optimal ~6.5-7.5); potential for off-target reaction at higher pH.[3][4]
CuAAC (Click)	Azide/Alkyne	Very High (>95%)[9]	Very High (Triazole)	Fast (15-60 minutes)	Requires copper catalyst which can be cytotoxic.[10][11]
SPAAC (Click)	Azide/Cyclooctyne	High (>90%)[7][12]	Very High (Triazole)	Moderate to Fast	No catalyst required; ideal for live-cell applications.[8]

Efficiency can vary based on specific reactants and conditions.[2][20]

## Experimental Protocols

### Protocol 1: General Procedure for Labeling an Antibody with an NHS-Ester Fluorescent Dye (e.g., Alexa Fluor 488)

## NHS Ester)

### 1. Materials:

- Antibody solution (1-10 mg/mL in amine-free buffer, e.g., PBS, pH 7.4)
- Alexa Fluor 488 NHS ester (or other amine-reactive dye)
- Anhydrous dimethyl sulfoxide (DMSO)
- 1 M Sodium bicarbonate buffer, pH 8.3
- Purification column (e.g., size-exclusion chromatography)
- Reaction tubes
- Pipettes and tips

### 2. Procedure:

- Prepare the Antibody:
  - Ensure the antibody is in an amine-free buffer. If Tris or glycine are present, perform a buffer exchange into PBS.
  - Adjust the antibody concentration to 2-5 mg/mL.
- Prepare the Dye Stock Solution:
  - Allow the vial of Alexa Fluor 488 NHS ester to warm to room temperature before opening to prevent moisture condensation.
  - Prepare a 10 mM stock solution of the dye in anhydrous DMSO. Vortex to dissolve completely. This solution should be prepared fresh.[\[21\]](#)
- Perform the Labeling Reaction:
  - Add 1/10th volume of 1 M sodium bicarbonate to the antibody solution to raise the pH to ~8.3.

- Add a 10- to 20-fold molar excess of the dye stock solution to the antibody solution while gently vortexing. The optimal dye-to-protein ratio may need to be determined empirically.
- Incubate the reaction for 1 hour at room temperature, protected from light.
- Purify the Conjugate:
  - Separate the labeled antibody from the unreacted dye using a size-exclusion chromatography column equilibrated with PBS.
  - Collect the fractions containing the fluorescently labeled antibody.
- Characterize the Conjugate:
  - Determine the protein concentration and the degree of labeling (DOL) by measuring the absorbance at 280 nm and the absorbance maximum of the dye.

## Protocol 2: Site-Specific Protein Labeling with a Maleimide-Reactive Fluorescent Dye

### 1. Materials:

- Protein solution containing a free cysteine (1-5 mg/mL in degassed, thiol-free buffer, e.g., PBS, pH 7.2)
- Maleimide-activated fluorescent dye
- Anhydrous DMSO or DMF
- Tris(2-carboxyethyl)phosphine (TCEP) (optional, for reducing disulfide bonds)
- Quenching reagent (e.g.,  $\beta$ -mercaptoethanol or cysteine)
- Purification column (e.g., size-exclusion chromatography)

### 2. Procedure:

- Prepare the Protein:

- Ensure the protein is in a degassed, thiol-free buffer at pH 7.0-7.5.
- If the target cysteine is in a disulfide bond, reduce it by adding a 10-fold molar excess of TCEP and incubating for 30-60 minutes at room temperature. Remove excess TCEP by buffer exchange.[\[3\]](#)[\[22\]](#)
- Prepare the Dye Stock Solution:
  - Prepare a 10 mM stock solution of the maleimide dye in anhydrous DMSO or DMF.[\[3\]](#)
- Perform the Labeling Reaction:
  - Add a 10- to 20-fold molar excess of the dye stock solution to the protein solution.
  - Incubate for 2 hours at room temperature or overnight at 4°C, protected from light.[\[22\]](#)
- Quench the Reaction:
  - Add a quenching reagent like  $\beta$ -mercaptoethanol to a final concentration of ~10 mM to react with any excess maleimide. Incubate for 15 minutes.[\[22\]](#)
- Purify the Conjugate:
  - Purify the labeled protein using size-exclusion chromatography.[\[3\]](#)[\[22\]](#)

## Protocol 3: Labeling of an Alkyne-Modified Oligonucleotide via Copper-Catalyzed Click Chemistry (CuAAC)

### 1. Materials:

- Alkyne-modified oligonucleotide
- Azide-functionalized fluorescent dye
- Copper(II) sulfate ( $\text{CuSO}_4$ )
- Copper(I)-stabilizing ligand (e.g., THPTA or TBTA)[\[9\]](#)

- Sodium ascorbate
- DMSO
- Triethylammonium acetate buffer (TEAA)
- Purification supplies (e.g., HPLC or PAGE)

## 2. Procedure:

- Prepare Stock Solutions:
  - Dissolve the alkyne-modified oligonucleotide in nuclease-free water.
  - Prepare a 10 mM stock solution of the azide-dye in DMSO.[\[9\]](#)
  - Prepare a 100 mM stock solution of CuSO<sub>4</sub> in water.
  - Prepare a 200 mM stock solution of the ligand in water.
  - Prepare a 100 mM stock solution of sodium ascorbate in water (prepare fresh).
- Perform the Click Reaction:
  - In a reaction tube, combine the alkyne-oligonucleotide, TEAA buffer (final concentration 0.2 M), and DMSO.
  - Add the azide-dye solution (typically a 1.5 to 5-fold molar excess over the oligonucleotide).  
[\[9\]](#)
  - Pre-mix the CuSO<sub>4</sub> and ligand solutions.
  - Add the CuSO<sub>4</sub>/ligand complex to the reaction mixture.
  - Initiate the reaction by adding the sodium ascorbate solution.
  - Incubate at room temperature for 30-60 minutes.
- Purify the Conjugate:



- Purify the labeled oligonucleotide using reverse-phase HPLC or polyacrylamide gel electrophoresis (PAGE).<sup>[9][23]</sup>

## Mandatory Visualizations

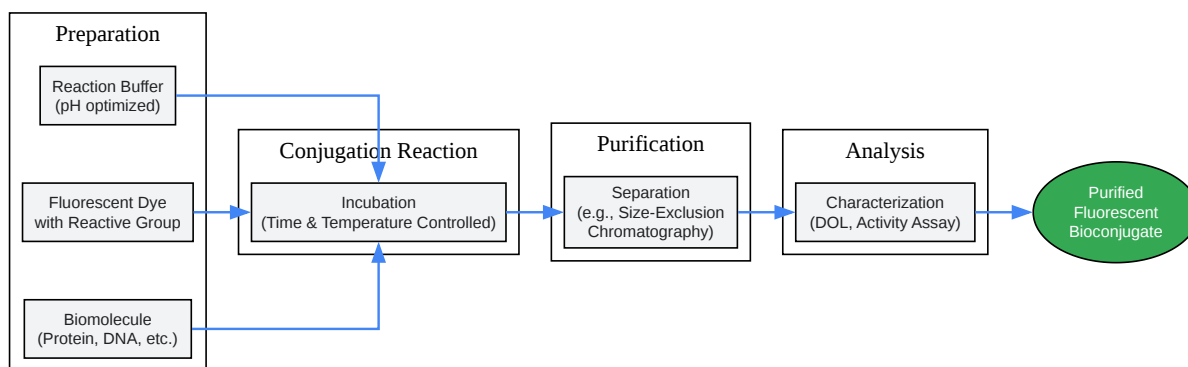

[Click to download full resolution via product page](#)

Caption: General experimental workflow for fluorescent bioconjugation.

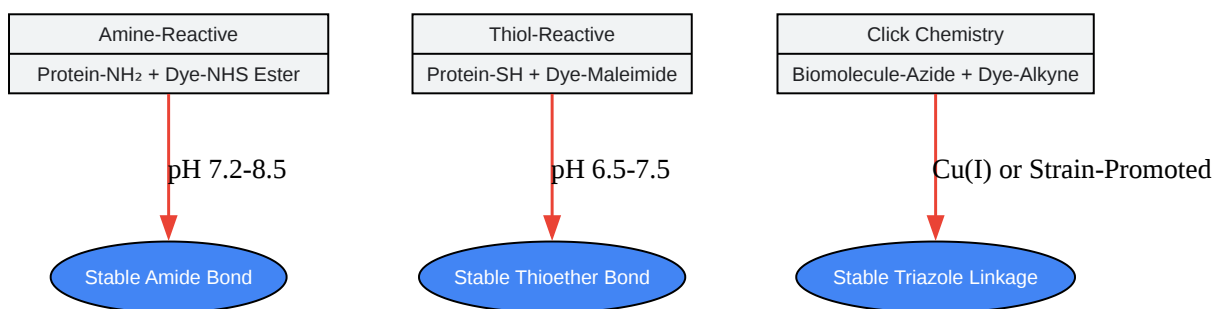

[Click to download full resolution via product page](#)

Caption: Core bioconjugation chemical reactions.

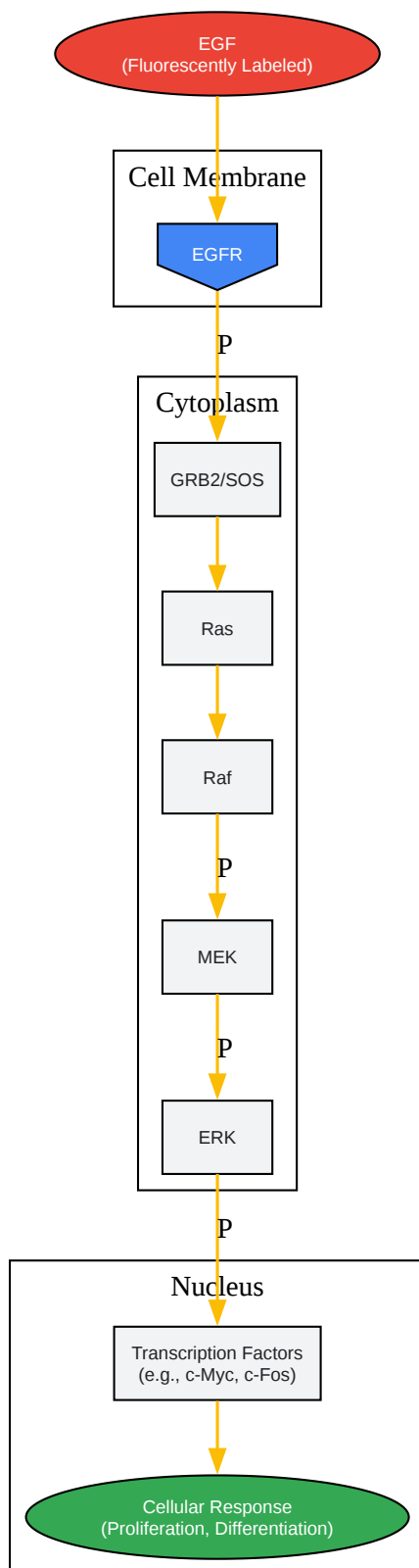

[Click to download full resolution via product page](#)

Caption: Visualizing the MAPK/ERK signaling pathway with a fluorescent ligand.

## Applications in Research and Drug Development

Fluorescently labeled biomolecules are indispensable tools across various scientific disciplines.

- **Cellular Imaging:** Fluorescent antibodies and probes enable the visualization of specific proteins and organelles within fixed and living cells, providing insights into their localization and dynamics.[\[24\]](#)[\[25\]](#)
- **Flow Cytometry:** Labeled antibodies are used to identify and quantify specific cell populations based on the expression of cell surface and intracellular markers.
- **Immunoassays:** Techniques like ELISA and Western blotting utilize fluorescently tagged antibodies for the sensitive detection and quantification of target antigens.
- **Drug Development:** Bioconjugation is central to the development of antibody-drug conjugates (ADCs), where a potent cytotoxic drug is linked to a monoclonal antibody that targets cancer cells.[\[20\]](#) Fluorescent dyes can be used as non-toxic surrogates in the process development of ADCs.
- **Pharmacokinetic Studies:** Fluorescent labeling allows for the tracking of therapeutic molecules in vivo, providing crucial data on their distribution, metabolism, and clearance.[\[26\]](#)

## Troubleshooting Common Issues

Problem	Possible Cause(s)	Recommended Solution(s)
Low Conjugation Yield	- Suboptimal pH- Hydrolysis of reactive group- Inactive biomolecule or dye- Insufficient molar excess of dye	- Optimize buffer pH for the specific chemistry.- Use fresh, anhydrous solvents for dye stock solutions.- Ensure the biomolecule and dye are of high quality.- Perform a titration to find the optimal dye-to-biomolecule ratio.[5][27][28]
Protein Precipitation	- High concentration of organic solvent- Over-labeling of the protein	- Minimize the volume of the dye stock solution added.- Reduce the molar excess of the labeling reagent.[22]
Loss of Biological Activity	- Labeling at a critical functional site- Denaturation during the reaction	- Use site-specific labeling techniques (e.g., maleimide chemistry for a non-essential cysteine).- Perform the reaction at a lower temperature (e.g., 4°C).[27]
High Background/Non-specific Staining	- Unreacted free dye- Non-specific binding of the conjugate	- Ensure thorough purification of the conjugate.- Include appropriate blocking steps in staining protocols.- Titrate the conjugate to the lowest effective concentration.

## Conclusion

Bioconjugation with fluorescent dyes is a powerful and versatile technology that continues to drive innovation in biological research and medicine. A thorough understanding of the underlying chemistries, careful optimization of reaction conditions, and rigorous characterization of the final conjugate are essential for obtaining reliable and reproducible results. This guide provides a solid foundation for researchers to successfully design and

execute fluorescent bioconjugation experiments, enabling them to illuminate the intricate workings of biological systems.

### Need Custom Synthesis?

BenchChem offers custom synthesis for rare earth carbides and specific isotopic labeling.

Email: [info@benchchem.com](mailto:info@benchchem.com) or [Request Quote Online](#).

## References

- 1. Guide to Cyanine Dyes: Cy7, Cy5, Cy5.5, Cy3 [bocsci.com]
- 2. benchchem.com [benchchem.com]
- 3. lumiprobe.com [lumiprobe.com]
- 4. lifetein.com [lifetein.com]
- 5. Troubleshooting [chem.rochester.edu]
- 6. pubs.acs.org [pubs.acs.org]
- 7. Strain-Promoted Azide-Alkyne Cycloaddition [manu56.magtech.com.cn]
- 8. Strain-Promoted Alkyne-Azide Cycloadditions (SPAAC) Reveal New Features of Glycoconjugate Biosynthesis - PMC [pmc.ncbi.nlm.nih.gov]
- 9. lumiprobe.com [lumiprobe.com]
- 10. Click Chemistry [organic-chemistry.org]
- 11. bioconjugation.bocsci.com [bioconjugation.bocsci.com]
- 12. jcmarot.com [jcmarot.com]
- 13. The Alexa Fluor Dye Series—Note 1.1 | Thermo Fisher Scientific - TW [thermofisher.com]
- 14. Alexa Fluor Dyes Spanning the Visible and Infrared Spectrum—Section 1.3 | Thermo Fisher Scientific - US [thermofisher.com]
- 15. Fluorophores [microscopy.unc.edu]
- 16. Fluorescence quantum yields (QY) and lifetimes ( $\tau$ ) for Alexa Fluor dyes—Table 1.5 | Thermo Fisher Scientific - US [thermofisher.com]
- 17. researchgate.net [researchgate.net]
- 18. qiagen.com [qiagen.com]

- 19. [benchchem.com](https://www.benchchem.com) [[benchchem.com](https://www.benchchem.com)]
- 20. [benchchem.com](https://www.benchchem.com) [[benchchem.com](https://www.benchchem.com)]
- 21. [benchchem.com](https://www.benchchem.com) [[benchchem.com](https://www.benchchem.com)]
- 22. [benchchem.com](https://www.benchchem.com) [[benchchem.com](https://www.benchchem.com)]
- 23. [interchim.fr](https://www.interchim.fr) [[interchim.fr](https://www.interchim.fr)]
- 24. Fluorescence Imaging of Epidermal Growth Factor Receptor Tyrosine Kinase Inhibitor Resistance in Non-Small Cell Lung Cancer - PMC [[pmc.ncbi.nlm.nih.gov](https://pubmed.ncbi.nlm.nih.gov)]
- 25. Visualization and quantitation of epidermal growth factor receptor homodimerization and activation with a proximity ligation assay - PMC [[pmc.ncbi.nlm.nih.gov](https://pubmed.ncbi.nlm.nih.gov)]
- 26. MAPK Signaling Resources | Cell Signaling Technology [[cellsignal.com](https://www.cellsignal.com)]
- 27. Bioconjugation Chemistry: Challenges and Solutions [[kbdna.com](https://www.kbdna.com)]
- 28. [benchchem.com](https://www.benchchem.com) [[benchchem.com](https://www.benchchem.com)]
- To cite this document: BenchChem. [An In-depth Technical Guide to Bioconjugation with Fluorescent Dyes]. BenchChem, [2025]. [Online PDF]. Available at: [<https://www.benchchem.com/product/b8116030#introduction-to-bioconjugation-with-fluorescent-dyes>]

---

### Disclaimer & Data Validity:

The information provided in this document is for Research Use Only (RUO) and is strictly not intended for diagnostic or therapeutic procedures. While BenchChem strives to provide accurate protocols, we make no warranties, express or implied, regarding the fitness of this product for every specific experimental setup.

**Technical Support:** The protocols provided are for reference purposes. Unsure if this reagent suits your experiment? [[Contact our Ph.D. Support Team for a compatibility check](#)]

**Need Industrial/Bulk Grade?** [Request Custom Synthesis Quote](#)

# BenchChem

Our mission is to be the trusted global source of essential and advanced chemicals, empowering scientists and researchers to drive progress in science and industry.

## Contact

Address: 3281 E Guasti Rd

Ontario, CA 91761, United States

Phone: (601) 213-4426

Email: [info@benchchem.com](mailto:info@benchchem.com)