

An In-depth Technical Guide to Arcaine Sulfate

Author: BenchChem Technical Support Team. **Date:** December 2025

Compound of Interest

Compound Name: *Arcaine sulfate*

Cat. No.: *B1330173*

[Get Quote](#)

For Researchers, Scientists, and Drug Development Professionals

This technical guide provides a comprehensive overview of the chemical properties, mechanism of action, and relevant experimental contexts of **arcaine sulfate**. The information is intended for researchers and professionals in the fields of neuroscience, pharmacology, and drug development.

Core Chemical and Physical Properties

Arcaine sulfate is a well-characterized compound, recognized for its role as a potent antagonist of the N-methyl-D-aspartate (NMDA) receptor.[1] It also exhibits inhibitory effects on nitric oxide synthase (NOS).[2] The fundamental properties of **arcaine sulfate** are summarized in the table below.

Property	Value	Source
Molecular Weight	270.31 g/mol	[2]
Molecular Formula	C ₆ H ₁₆ N ₆ ·H ₂ SO ₄	[2]
Alternate Names	1,4-Diguanidinobutane sulfate salt	[1]
Appearance	White to off-white crystalline powder	Chem-Impex
Melting Point	>280 °C	Sigma-Aldrich
Solubility	Soluble in water (25mM)	Hello Bio

Mechanism of Action: NMDA Receptor Antagonism

Arcaine sulfate's primary mechanism of action is the blockade of the NMDA receptor ion channel. It functions as a competitive antagonist at the polyamine binding site and as a voltage-dependent open-channel blocker.[3] This means that arcaine enters and occludes the ion channel pore when the receptor is in its open state, preventing the influx of calcium ions. The strength of this block is dependent on the transmembrane voltage.[3]

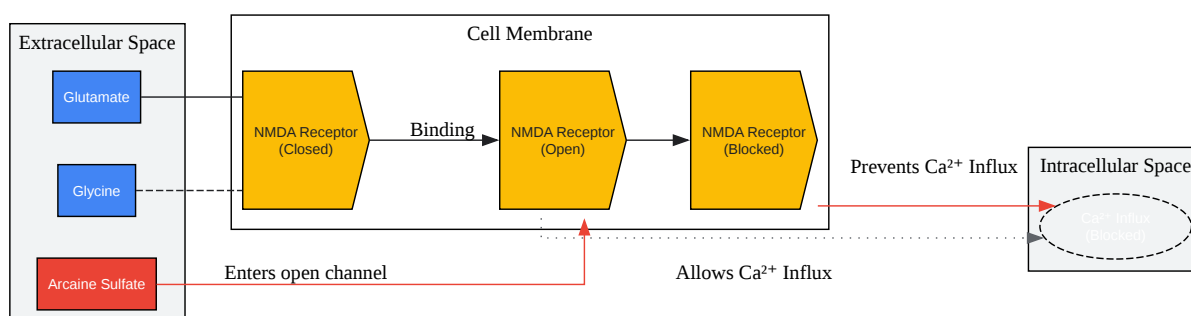

[Click to download full resolution via product page](#)

Mechanism of **Arcaine Sulfate** as an NMDA Receptor Open-Channel Blocker.

Inhibition of Nitric Oxide Synthase

In addition to its effects on the NMDA receptor, **arcaine sulfate** is also known to be an inhibitor of nitric oxide synthase (NOS).[2] NOS enzymes are responsible for the synthesis of nitric oxide (NO), a critical signaling molecule involved in various physiological processes, including neurotransmission and vasodilation. The inhibition of NOS by **arcaine sulfate** suggests its potential to modulate NO-dependent signaling pathways.

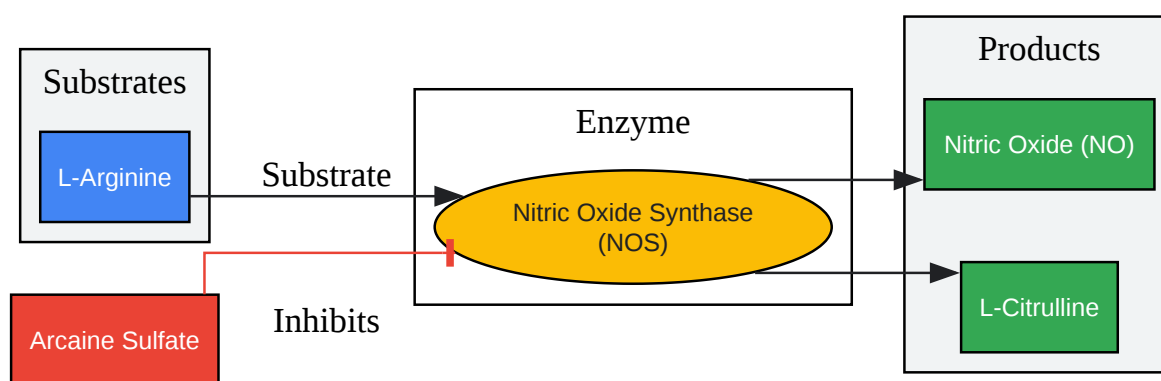

[Click to download full resolution via product page](#)

Inhibitory Action of **Arcaine Sulfate** on Nitric Oxide Synthase.

Experimental Protocols

Detailed, proprietary synthesis and analysis protocols for **arcaine sulfate** are not readily available in the public domain. However, this section outlines generalized experimental methodologies based on standard biochemical and pharmacological techniques.

a. Synthesis of 1,4-Diguanidinobutane Sulfate (**Arcaine Sulfate**)

A plausible synthesis route for **arcaine sulfate** involves the guanylation of a diamine precursor. A generalized workflow is presented below.

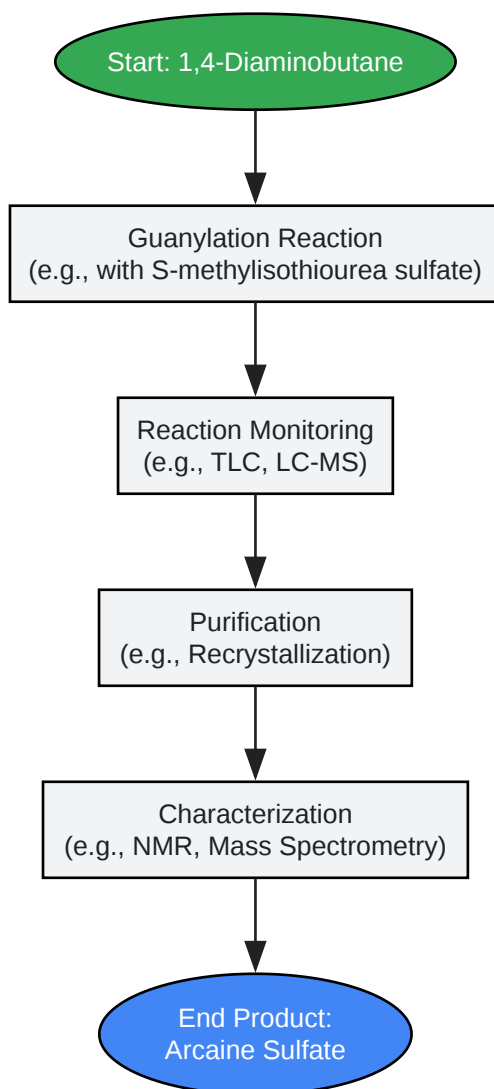

[Click to download full resolution via product page](#)

Generalized Workflow for the Synthesis of **Arcaine Sulfate**.

b. Quantification of **Arcaine Sulfate** using RP-HPLC

Reverse-phase high-performance liquid chromatography (RP-HPLC) is a suitable method for the quantification of **arcaine sulfate**. A general protocol would involve the following steps:

- **Standard Preparation:** Prepare a stock solution of high-purity **arcaine sulfate** in an appropriate solvent (e.g., water) and create a series of dilutions to generate a calibration curve.

- Sample Preparation: Dissolve the sample containing **arcaine sulfate** in the mobile phase and filter it through a 0.22 μm syringe filter.
- Chromatographic Conditions:
 - Column: C18 column (e.g., 4.6 x 250 mm).
 - Mobile Phase: A mixture of an aqueous buffer (e.g., phosphate buffer) and an organic solvent (e.g., methanol or acetonitrile). The exact ratio should be optimized.
 - Flow Rate: Typically 1 mL/min.
 - Detection: UV detection at a wavelength determined by the UV spectrum of **arcaine sulfate**.
 - Injection Volume: 20 μL .
- Analysis: Inject the standards and samples. Quantify the amount of **arcaine sulfate** in the samples by comparing the peak areas to the calibration curve.

c. Investigating NMDA Receptor Antagonism via Whole-Cell Patch-Clamp Electrophysiology

The whole-cell patch-clamp technique is a powerful tool to study the effects of **arcaine sulfate** on NMDA receptor-mediated currents in cultured neurons.

- Cell Culture: Culture primary neurons (e.g., hippocampal or cortical neurons) on glass coverslips.
- Recording Setup: Use a patch-clamp amplifier and data acquisition system.
- Solutions:
 - External Solution: A physiological salt solution containing agonists for the NMDA receptor (e.g., NMDA and glycine) and blockers for other channels.
 - Internal Solution: A solution mimicking the intracellular ionic composition, loaded into the patch pipette.

- Procedure:
 - Obtain a whole-cell recording from a neuron.
 - Apply the external solution containing NMDA and glycine to evoke an inward current.
 - Co-apply **arcaine sulfate** with the agonists to observe the inhibition of the NMDA receptor-mediated current.
 - Vary the holding potential to study the voltage-dependent nature of the block.
- Data Analysis: Measure the peak current amplitude in the absence and presence of **arcaine sulfate** to determine the extent of inhibition and calculate parameters such as the IC₅₀.

Need Custom Synthesis?

BenchChem offers custom synthesis for rare earth carbides and specific isotopic labeling.

Email: info@benchchem.com or [Request Quote Online](#).

References

- 1. medchemexpress.com [medchemexpress.com]
- 2. Arcaine sulfate | NMDA receptor antagonist | Hello Bio [hellobio.com]
- 3. Arcaine blocks N-methyl-D-aspartate receptor responses by an open channel mechanism: whole-cell and single-channel recording studies in cultured hippocampal neurons - PubMed [pubmed.ncbi.nlm.nih.gov]
- To cite this document: BenchChem. [An In-depth Technical Guide to Arcaine Sulfate]. BenchChem, [2025]. [Online PDF]. Available at: [https://www.benchchem.com/product/b1330173#arcaine-sulfate-molecular-weight-and-formula]

Disclaimer & Data Validity:

The information provided in this document is for Research Use Only (RUO) and is strictly not intended for diagnostic or therapeutic procedures. While BenchChem strives to provide

accurate protocols, we make no warranties, express or implied, regarding the fitness of this product for every specific experimental setup.

Technical Support: The protocols provided are for reference purposes. Unsure if this reagent suits your experiment? [[Contact our Ph.D. Support Team for a compatibility check](#)]

Need Industrial/Bulk Grade? [Request Custom Synthesis Quote](#)

BenchChem

Our mission is to be the trusted global source of essential and advanced chemicals, empowering scientists and researchers to drive progress in science and industry.

Contact

Address: 3281 E Guasti Rd

Ontario, CA 91761, United States

Phone: (601) 213-4426

Email: info@benchchem.com