

# An In-depth Technical Guide on the Cellular Functions of c-Src

**Author:** BenchChem Technical Support Team. **Date:** December 2025

## Compound of Interest

Compound Name: RR-SRC

Cat. No.: B013104

[Get Quote](#)

Audience: Researchers, scientists, and drug development professionals.

## Executive Summary

c-Src is a non-receptor tyrosine kinase that serves as a critical node in intracellular signaling networks.[1][2] First identified as the cellular homolog of the viral v-Src oncogene, c-Src plays a fundamental role in regulating a wide array of normal physiological processes, including cell proliferation, survival, differentiation, migration, and angiogenesis.[3][4] Its activity is tightly regulated through a series of intramolecular interactions and phosphorylation events. Dysregulation, often through overexpression or constitutive activation, is a hallmark of numerous human cancers, making c-Src a significant target for therapeutic intervention.[3][5][6] This document details the core functions of c-Src, its signaling pathways, subcellular localization, role in oncology, and key experimental protocols for its study.

## Structure and Regulation of c-Src

c-Src is a 60 kDa protein composed of several functional domains that dictate its activity and interactions.[7]

- SH4 (Src Homology 4) Domain: Located at the N-terminus, this domain contains a myristoylation site, which is crucial for anchoring c-Src to cellular membranes.[7][8]
- Unique Domain: This region varies among Src family kinases (SFKs) and contributes to specific binding partnerships.

- SH3 (Src Homology 3) Domain: Binds to proline-rich sequences in partner proteins, mediating protein-protein interactions.
- SH2 (Src Homology 2) Domain: Recognizes and binds to phosphorylated tyrosine residues on other proteins, including its own C-terminal tail.
- Catalytic (Kinase) Domain (SH1): Responsible for the phosphotransferase activity, transferring a phosphate group from ATP to a tyrosine residue on a substrate protein.
- C-terminal Regulatory Tail: Contains a critical inhibitory tyrosine residue (Tyr527 in chickens, Tyr530 in humans).

Regulation of c-Src activity is a dynamic process primarily controlled by phosphorylation:

- Inactive State: In its basal state, c-Src is kept inactive by the phosphorylation of Tyr530 by C-terminal Src Kinase (Csk).[9] This phosphotyrosine residue binds to the SH2 domain, inducing a "closed" and catalytically repressed conformation.[7][9][10][11]
- Active State: Activation is initiated by the dephosphorylation of Tyr530, often by protein tyrosine phosphatases.[9] This disrupts the intramolecular inhibition, leading to an "open" conformation.[9] This allows for the autophosphorylation of a tyrosine residue in the activation loop of the kinase domain (Tyr416 in chickens, Tyr419 in humans), which is essential for full catalytic activity.[7][9][12]

## Core Cellular Functions and Signaling Pathways

c-Src is a central transducer for numerous extracellular signals, integrating them into downstream cellular responses.[13]

### Upstream Activation

c-Src can be activated by a diverse array of transmembrane proteins, including:

- Receptor Tyrosine Kinases (RTKs): Such as Epidermal Growth Factor Receptor (EGFR) and Platelet-Derived Growth Factor Receptor (PDGFR).[2][4][7]
- G-protein Coupled Receptors (GPCRs).[2][7]

- Integrins and Adhesion Receptors.[3][7]
- Cytokine Receptors.[7]

## Downstream Signaling Cascades

Once activated, c-Src phosphorylates a multitude of substrate proteins, initiating several key signaling pathways that govern cellular behavior.[3]

- Ras-MAPK Pathway: c-Src activation can lead to the stimulation of the Ras-Raf-MEK-ERK cascade, which is pivotal for regulating gene expression related to cell proliferation and differentiation.[2][3]
- PI3K/AKT Pathway: c-Src can activate Phosphoinositide 3-kinase (PI3K), leading to the activation of Akt. This pathway is a primary regulator of cell survival, growth, and metabolism. [3]
- JAK/STAT Pathway: c-Src is involved in activating the Janus kinase (JAK) and Signal Transducer and Activator of Transcription (STAT) pathway, particularly STAT3, which controls the transcription of genes involved in proliferation and survival.[3]
- Focal Adhesion Kinase (FAK)/Paxillin Pathway: Through its interaction with FAK and other focal adhesion proteins like paxillin, c-Src plays a crucial role in regulating cell adhesion, migration, and invasion by modulating the cytoskeleton.[3]

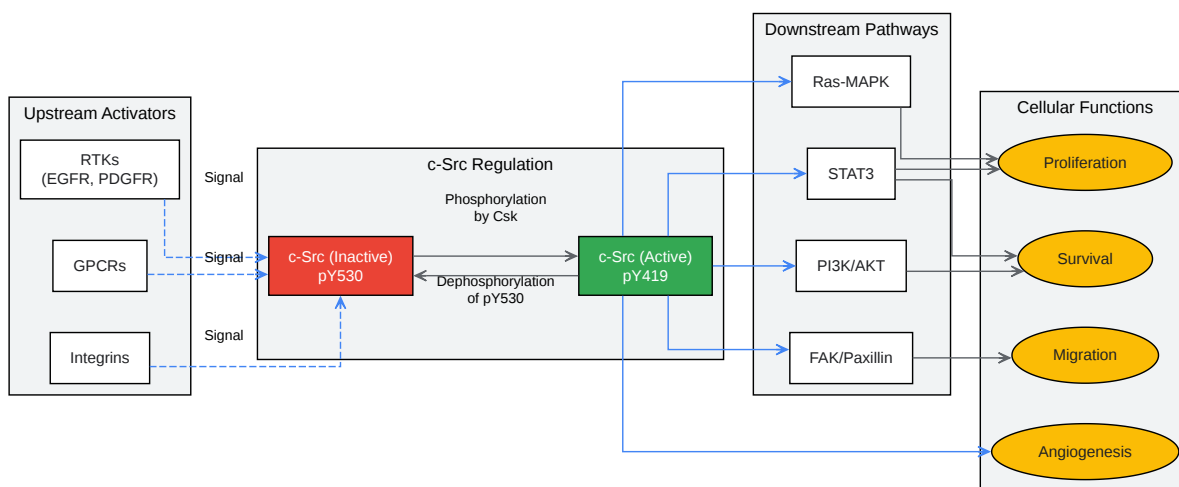

[Click to download full resolution via product page](#)

Caption: c-Src integrates signals from upstream receptors to activate key downstream pathways.

## Subcellular Localization

The function of c-Src is intimately linked to its location within the cell.[13] N-terminal myristoylation facilitates its association with cellular membranes.[8][14] c-Src is dynamically localized to various compartments:

- Plasma Membrane: Where it transduces signals from cell surface receptors.[13]
- Endosomes: It colocalizes with early endosome antigen 1 (EEA1) and the late endosome marker CD63, suggesting a role in endocytic trafficking and signaling.[8]

- Perinuclear Vesicles: A subpopulation of c-Src is found on the limiting membranes of perinuclear vesicles, which may be multivesicular bodies involved in the endocytic pathway. [15]
- Centrosomes and Cytoplasm: During different phases of the cell cycle, c-Src can be found at centrosomes and diffusely in the cytoplasm. [14][16]

## Role in Cancer

Aberrant c-Src activation is a common feature in many human cancers, where it promotes tumorigenesis by enhancing proliferation, survival, invasion, and angiogenesis. [3][6][7] This deregulation is typically due to overexpression or hyperactivity rather than activating mutations. [1]

Cancer Type	c-Src Expression/Activity Level	Reference
Colon Cancer	5 to 8-fold higher activity in premalignant polyps vs. normal mucosa.	[7]
Breast Cancer	Elevated expression levels compared to normal tissues.	[7]
Pancreatic Cancer	High levels of Src detected in tumor tissues and cell lines.	[1]
Prostate Cancer	Highly expressed in malignant cells compared to normal prostate cells.	[7]
General	Activation observed in ~50% of tumors from colon, liver, lung, breast, and pancreas.	[7]

## Quantitative Data Summary

The inhibitory activity of small molecules targeting c-Src is a critical parameter in drug development.

Inhibitor	Target Kinase	Ki (nM)	IC50 (nM)	Reference
Saracatinib (AZD0530)	c-Src	-	2.7	[17]
KB Src 4	c-Src	44	-	[18]
KB Src 4	Lck	-	-	[18]
KB Src 4	Fgr	-	-	[18]
KB Src 4	Yes	-	-	[18]

## Detailed Experimental Protocols

### Protocol 1: In Vitro c-Src Kinase Assay

This protocol describes a method to measure the kinase activity of recombinant c-Src and assess the potency of inhibitors.

#### Materials and Reagents:

- Recombinant active c-Src kinase
- Substrate: Poly(Glu, Tyr) 4:1 peptide or specific peptide substrate (e.g., cdc2 6-20)[19]
- Test Inhibitor (e.g., Saracatinib) dissolved in DMSO
- ATP, 10 mM stock solution
- Assay Buffer: 50 mM Tris-HCl (pH 7.5), 10 mM MgCl<sub>2</sub>, 1 mM EGTA, 2 mM DTT[19]
- Detection Reagent: ADP-Glo™ Kinase Assay kit (Promega) or similar
- 384-well or 96-well plates (white, opaque for luminescence)
- Plate reader capable of measuring luminescence

#### Procedure:

- Prepare Reagents: Dilute enzyme, substrate, ATP, and test inhibitor to desired concentrations in Assay Buffer.
- Reaction Setup: In a multi-well plate, add the following components:
  - 1  $\mu\text{L}$  of test inhibitor (or DMSO for control).
  - 2  $\mu\text{L}$  of a mix containing c-Src enzyme and substrate.
  - Incubate for 10 minutes at room temperature.
- Initiate Reaction: Add 2  $\mu\text{L}$  of ATP solution to each well to start the kinase reaction.[20]
- Incubation: Incubate the plate at 30°C for 60 minutes.[20]
- Stop Reaction & Detect ADP:
  - Add 5  $\mu\text{L}$  of ADP-Glo™ Reagent to terminate the kinase reaction and deplete remaining ATP.
  - Incubate for 40 minutes at room temperature.[21]
  - Add 10  $\mu\text{L}$  of Kinase Detection Reagent to convert ADP to ATP and generate a luminescent signal.
  - Incubate for 30 minutes at room temperature.[21]
- Data Acquisition: Measure luminescence using a plate reader. The signal intensity is directly proportional to the amount of ADP produced and thus to c-Src kinase activity.
- Data Analysis: Calculate the percentage of inhibition for each inhibitor concentration relative to the DMSO control and determine the IC<sub>50</sub> value.

## Protocol 2: Immunoprecipitation (IP) of c-Src from Cell Lysates

This protocol details the enrichment of c-Src from cultured cells for subsequent analysis.[22]

#### Materials and Reagents:

- Cultured cells (e.g., NSC34, C2C12)[23]
- Phosphate-buffered saline (PBS), ice-cold
- Lysis Buffer (e.g., modified RIPA buffer: 50 mM Tris-HCl pH 7.4, 150 mM NaCl, 1% NP-40, 0.25% Sodium deoxycholate, 1 mM EDTA) supplemented with fresh protease and phosphatase inhibitors.[17]
- Anti-Src primary antibody
- Isotype control IgG
- Protein A/G magnetic beads or agarose beads
- Wash Buffer (Lysis buffer or similar)
- Elution Buffer (e.g., 2x Laemmli sample buffer)
- Microcentrifuge and magnetic rack (for magnetic beads)

#### Procedure:

- Cell Lysis:
  - Wash cultured cells with ice-cold PBS.
  - Add ice-cold Lysis Buffer to the plate, scrape the cells, and transfer the lysate to a microcentrifuge tube.[23]
  - Incubate on ice for 30 minutes with vortexing.[22]
  - Centrifuge at ~14,000 x g for 15 minutes at 4°C to pellet cell debris.
  - Transfer the supernatant (protein lysate) to a new tube. Determine protein concentration (e.g., BCA assay).
- Immunocapture:



- Pre-clear the lysate by incubating with beads for 30-60 minutes at 4°C.
- To 500-1000 µg of pre-cleared lysate, add 2-4 µg of anti-Src antibody (and a parallel sample with isotype control IgG).
- Incubate with gentle rotation for 2 hours to overnight at 4°C.
- Bead Capture:
  - Add 20-30 µL of equilibrated Protein A/G beads to each sample.
  - Incubate with rotation for 1-2 hours at 4°C.[\[24\]](#)
- Washing:
  - Pellet the beads by centrifugation or using a magnetic rack. Discard the supernatant.
  - Wash the beads 3-4 times with 1 mL of ice-cold Wash Buffer.[\[12\]](#)
- Elution:
  - After the final wash, remove all supernatant.
  - Resuspend the bead pellet in 20-40 µL of 2x Laemmli sample buffer.
  - Boil at 95-100°C for 5-10 minutes to elute the protein and denature it for SDS-PAGE.[\[17\]](#)  
[\[22\]](#)
  - Centrifuge to pellet the beads and collect the supernatant containing the immunoprecipitated c-Src.

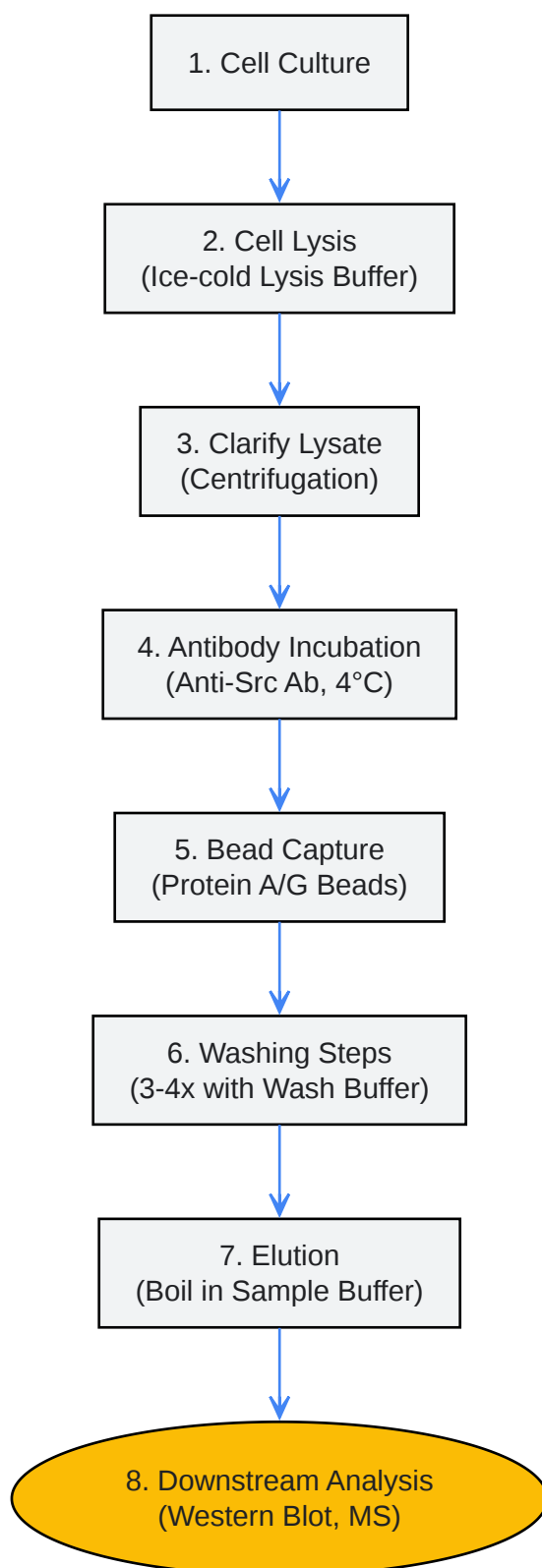

[Click to download full resolution via product page](#)

Caption: A generalized workflow for the immunoprecipitation of c-Src.

## Protocol 3: Western Blot Analysis of c-Src Phosphorylation

This protocol is for detecting total c-Src and its active, phosphorylated form (p-Src Tyr416) in response to an inhibitor.[17]

### Materials and Reagents:

- Protein lysates from inhibitor-treated and control cells (prepared as in 7.2)
- SDS-PAGE gels, running buffer, and electrophoresis apparatus
- Transfer buffer, PVDF or nitrocellulose membranes, and transfer apparatus
- Blocking Buffer: 5% Bovine Serum Albumin (BSA) or non-fat dry milk in TBST (Tris-buffered saline with 0.1% Tween-20)
- Primary Antibodies: Rabbit anti-phospho-Src (Tyr416) and Mouse anti-total Src, diluted in Blocking Buffer (e.g., 1:1000)
- Secondary Antibodies: HRP-conjugated anti-rabbit IgG and HRP-conjugated anti-mouse IgG
- Chemiluminescent substrate (ECL)
- Imaging system

### Procedure:

- Sample Preparation: Prepare protein lysates from cells treated with various concentrations of an inhibitor (e.g., Saracatinib). Normalize protein concentrations using a BCA assay. Add Laemmli buffer and boil samples for 5-10 minutes.[17]
- SDS-PAGE: Load 20-50 µg of protein per lane onto an SDS-polyacrylamide gel. Run the gel until the dye front reaches the bottom.[20]
- Protein Transfer: Transfer the separated proteins from the gel to a PVDF or nitrocellulose membrane.[20][25]

- **Blocking:** Block the membrane with Blocking Buffer for 1 hour at room temperature to prevent non-specific antibody binding.[\[20\]](#)[\[25\]](#)
- **Primary Antibody Incubation:** Incubate the membrane with the primary antibody for phospho-Src (Tyr416) overnight at 4°C with gentle agitation.[\[17\]](#)[\[20\]](#)
- **Washing:** Wash the membrane three times for 5-10 minutes each with TBST.[\[20\]](#)
- **Secondary Antibody Incubation:** Incubate the membrane with HRP-conjugated secondary antibody for 1 hour at room temperature.[\[20\]](#)
- **Detection:** Wash the membrane again with TBST. Apply the chemiluminescent substrate and capture the signal using an imaging system.[\[20\]](#)
- **Stripping and Re-probing (Optional):** To detect total c-Src on the same membrane, incubate the membrane in a mild stripping buffer for 10-20 minutes, wash, and re-block. Then, probe with the primary antibody for total c-Src (steps 5-8).[\[17\]](#)
- **Quantification:** Use image analysis software (e.g., ImageJ) to quantify the band intensities. Normalize the p-Src signal to the total Src signal for each sample.

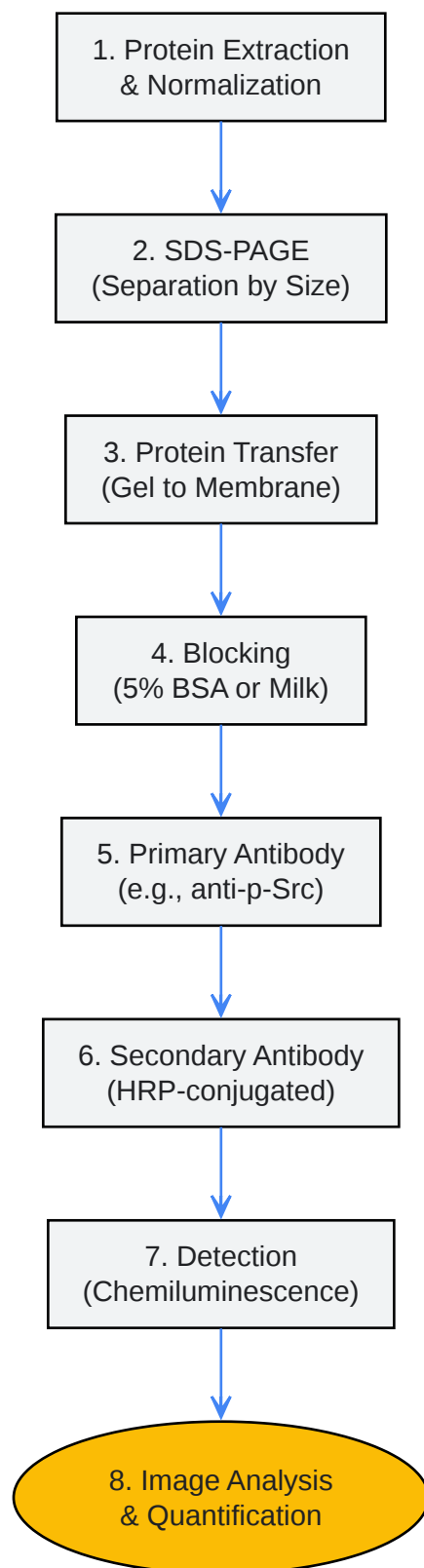

[Click to download full resolution via product page](#)

Caption: Key steps in the Western blot protocol for analyzing protein phosphorylation.

## Conclusion

c-*Src* is a multifaceted proto-oncogene that functions as a critical hub for a vast number of signaling pathways controlling essential cellular processes. Its tight regulation is paramount for normal cell physiology, and its frequent dysregulation in cancer underscores its significance as a high-value target for drug development. A thorough understanding of its complex biology, aided by the robust experimental protocols detailed herein, is essential for advancing both basic research and the development of novel cancer therapeutics.

### *Need Custom Synthesis?*

*BenchChem offers custom synthesis for rare earth carbides and specific isotopic labeling.*

*Email: [info@benchchem.com](mailto:info@benchchem.com) or [Request Quote Online](#).*

## References

- 1. The Role of *Src* in Solid Tumors - PMC [[pmc.ncbi.nlm.nih.gov](https://pubmed.ncbi.nlm.nih.gov/)]
- 2. [mdpi.com](https://mdpi.com) [[mdpi.com](https://mdpi.com)]
- 3. Role of c-*Src* in Carcinogenesis and Drug Resistance - PMC [[pmc.ncbi.nlm.nih.gov](https://pubmed.ncbi.nlm.nih.gov/)]
- 4. Identification of c-*Src* tyrosine kinase substrates in platelet-derived growth factor receptor signaling - PMC [[pmc.ncbi.nlm.nih.gov](https://pubmed.ncbi.nlm.nih.gov/)]
- 5. Role of *Src* expression and activation in human cancer | Semantic Scholar [[semanticscholar.org](https://www.semanticscholar.org)]
- 6. [spandidos-publications.com](https://spandidos-publications.com) [[spandidos-publications.com](https://spandidos-publications.com)]
- 7. Proto-oncogene tyrosine-protein kinase *Src* - Wikipedia [[en.wikipedia.org](https://en.wikipedia.org)]
- 8. c-*Src* trafficking and co-localization with the EGF Receptor promotes EGF ligand-independent EGF Receptor Activation and Signaling - PMC [[pmc.ncbi.nlm.nih.gov](https://pubmed.ncbi.nlm.nih.gov/)]
- 9. [researchgate.net](https://www.researchgate.net) [[researchgate.net](https://www.researchgate.net)]
- 10. The Activation of c-*Src* Tyrosine Kinase: Conformational Transition Pathway and Free Energy Landscape - PMC [[pmc.ncbi.nlm.nih.gov](https://pubmed.ncbi.nlm.nih.gov/)]
- 11. Regulation of c-*SRC* Activity and Function by the Adapter Protein CAS - PMC [[pmc.ncbi.nlm.nih.gov](https://pubmed.ncbi.nlm.nih.gov/)]

- 12. The Tyrosine Kinase Activity of c-Src Regulates Actin Dynamics and Organization of Podosomes in Osteoclasts - PMC [pmc.ncbi.nlm.nih.gov]
- 13. proteinswebteam.github.io [proteinswebteam.github.io]
- 14. journals.biologists.com [journals.biologists.com]
- 15. aacrjournals.org [aacrjournals.org]
- 16. rupress.org [rupress.org]
- 17. benchchem.com [benchchem.com]
- 18. benchchem.com [benchchem.com]
- 19. benchchem.com [benchchem.com]
- 20. benchchem.com [benchchem.com]
- 21. promega.com [promega.com]
- 22. protocols.io [protocols.io]
- 23. Immunoprecipitation of protein lysate from culture cells using Src antibody [protocols.io]
- 24. Co-IP Protocol-How To Conduct A Co-IP - Creative Proteomics [creative-proteomics.com]
- 25. Western blot protocol | Abcam [abcam.com]
- To cite this document: BenchChem. [An In-depth Technical Guide on the Cellular Functions of c-Src]. BenchChem, [2025]. [Online PDF]. Available at: [https://www.benchchem.com/product/b013104#what-is-the-function-of-rr-src-in-cells]

---

### Disclaimer & Data Validity:

The information provided in this document is for Research Use Only (RUO) and is strictly not intended for diagnostic or therapeutic procedures. While BenchChem strives to provide accurate protocols, we make no warranties, express or implied, regarding the fitness of this product for every specific experimental setup.

**Technical Support:** The protocols provided are for reference purposes. Unsure if this reagent suits your experiment? [[Contact our Ph.D. Support Team for a compatibility check](#)]

**Need Industrial/Bulk Grade?** [Request Custom Synthesis Quote](#)

# BenchChem

Our mission is to be the trusted global source of essential and advanced chemicals, empowering scientists and researchers to drive progress in science and industry.

## Contact

Address: 3281 E Guasti Rd

Ontario, CA 91761, United States

Phone: (601) 213-4426

Email: [info@benchchem.com](mailto:info@benchchem.com)