

A Technical Guide to the Physical and Chemical Properties of Lanthanum Sulfate

Author: BenchChem Technical Support Team. **Date:** December 2025

Compound of Interest

Compound Name: Lanthanum sulfate

Cat. No.: B162627

[Get Quote](#)

Audience: Researchers, Scientists, and Drug Development Professionals

Introduction: **Lanthanum sulfate**, with the chemical formula $\text{La}_2(\text{SO}_4)_3$, is an inorganic compound of the rare earth element lanthanum. It exists as an anhydrous salt and in several hydrated forms, with the nonahydrate ($\text{La}_2(\text{SO}_4)_3 \cdot 9\text{H}_2\text{O}$) and octahydrate ($\text{La}_2(\text{SO}_4)_3 \cdot 8\text{H}_2\text{O}$) being the most common.[1] This compound serves as a key intermediate in the extraction of lanthanum from its ores and is utilized in a variety of applications, including catalysis, water treatment, and the production of specialty glass and phosphors.[2][3][4] For researchers and professionals in drug development, understanding the precise physical and chemical properties of **lanthanum sulfate** is crucial for its potential application in areas such as biomedical imaging and novel material synthesis.[4][5] This guide provides an in-depth overview of its core properties, supported by experimental protocols and data.

Physical Properties

Lanthanum sulfate is typically a white, odorless, crystalline solid or powder.[1][6] The hydrated forms are known to be deliquescent, meaning they have a strong tendency to absorb moisture from the air.[7]

Quantitative Physical Data

The key physical properties of anhydrous and hydrated **lanthanum sulfate** are summarized below for easy comparison.

| Property | Anhydrous (La ₂ (SO ₄) ₃) | Nonahydrate (La ₂ (SO ₄) ₃ ·9H ₂ O) | Source(s) |
|-----------------------|---|---|-----------|
| Molar Mass | 566.00 g/mol | 728.15 g/mol | [1][6] |
| Appearance | Colorless powder | White solid, colorless crystals | [1][8] |
| Density | 3.60 g/cm ³ (at 15 °C) | 2.82 g/cm ³ | [1][8] |
| Melting Point | Decomposes at high temperatures (see Section 2.1) | Decomposes upon heating | [1][8] |
| Crystal Structure | Monoclinic (β-form) | Hexagonal | [1][9] |
| Solubility in Water | 2.14 g/100 g (25 °C) 0.69 g/100 g (100 °C) | 2.7 g/100 mL (20 °C) | [1][8] |
| Solubility in Ethanol | Sparingly soluble to insoluble | Insoluble | [1][8] |

Crystal Structure

The crystal structure of **lanthanum sulfate** varies with its hydration state. The nonahydrate, La₂(SO₄)₃·9H₂O, crystallizes in a hexagonal system with the space group P6₃.^[1] A polymorphic anhydrous form, β-La₂(SO₄)₃, obtained through thermal dehydration, exhibits a monoclinic crystal system with the space group C2/c.^{[9][10]}

Chemical Properties

Lanthanum sulfate is a moderately water and acid-soluble source of lanthanum.^{[2][7]} Its chemical behavior is characterized by its thermal decomposition pathway and its interactions in aqueous solutions.

Thermal Stability and Decomposition

Lanthanum sulfate undergoes a multi-stage decomposition upon heating. The hydrated forms first lose water molecules to yield the anhydrous salt.^[1] The anhydrous form is stable up to a

certain temperature, after which it decomposes into lanthanum oxysulfate ($\text{La}_2\text{O}_2\text{SO}_4$) and finally into lanthanum(III) oxide (La_2O_3) at higher temperatures.[1][11]

The decomposition pathway is as follows:

- Dehydration: $\text{La}_2(\text{SO}_4)_3 \cdot 9\text{H}_2\text{O} \rightarrow \text{La}_2(\text{SO}_4)_3 + 9\text{H}_2\text{O}$ (occurs in stages, complete around 300 °C)[1]
- First Decomposition: $\text{La}_2(\text{SO}_4)_3 \rightarrow \text{La}_2\text{O}_2\text{SO}_4 + 2\text{SO}_3$ (occurs at approximately 775 °C)[1]
- Final Decomposition: $\text{La}_2\text{O}_2\text{SO}_4 \rightarrow \text{La}_2\text{O}_3 + \text{SO}_3$ (occurs at approximately 1100-1150 °C)[1][8]

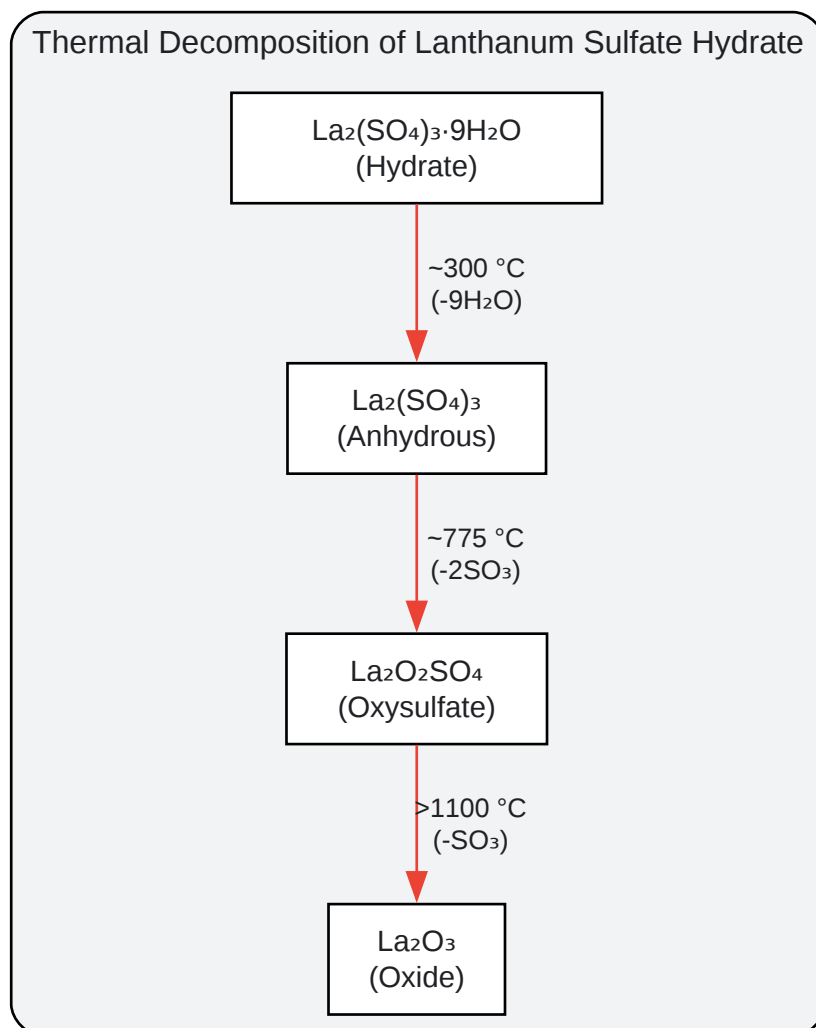

[Click to download full resolution via product page](#)

A simplified diagram of the thermal decomposition pathway.

Reactivity and Complex Formation

In aqueous solutions, **lanthanum sulfate** can form complex ions. Sulfate can act as a ligand, binding to the La^{3+} ion to form species such as LaSO_4^+ .^[12] The formation of these sulfato-complexes is an endothermic process, with the concentration of the complex increasing with temperature.^[13] Lanthanum metal readily dissolves in dilute sulfuric acid to form solutions containing the aquated La(III) ion, which likely exists as the complex ion $[\text{La}(\text{OH}_2)_9]^{3+}$.^[14] While soluble in acids, lanthanum compounds are generally stable in alkaline solutions.^[15]

Experimental Protocols

This section details methodologies for the synthesis and analysis of **lanthanum sulfate**, relevant for laboratory and research settings.

Synthesis of Lanthanum Sulfate Nonahydrate

This protocol describes the preparation of hydrated **lanthanum sulfate** from lanthanum oxide.

Methodology:

- **Reactant Preparation:** Carefully measure a stoichiometric amount of lanthanum(III) oxide (La_2O_3). Prepare a dilute solution of sulfuric acid (H_2SO_4).
- **Reaction:** Slowly add the lanthanum oxide powder to the stirred, dilute sulfuric acid solution. The reaction is exothermic and should be controlled. The reaction is: $\text{La}_2\text{O}_3 + 3\text{H}_2\text{SO}_4 \rightarrow \text{La}_2(\text{SO}_4)_3 + 3\text{H}_2\text{O}$.
- **Heating and Dissolution:** Gently heat the mixture to ensure all the oxide has reacted and dissolved completely.
- **Evaporation and Crystallization:** Reduce the volume of the solution by evaporation. Allow the concentrated solution to cool slowly to room temperature, which will induce the crystallization of **lanthanum sulfate** nonahydrate.^[1]
- **Isolation:** Collect the resulting white crystals by vacuum filtration.

- **Washing and Drying:** Wash the crystals with a small amount of cold deionized water to remove any excess acid, followed by a rinse with ethanol. Dry the product in a desiccator, as it is deliquescent.

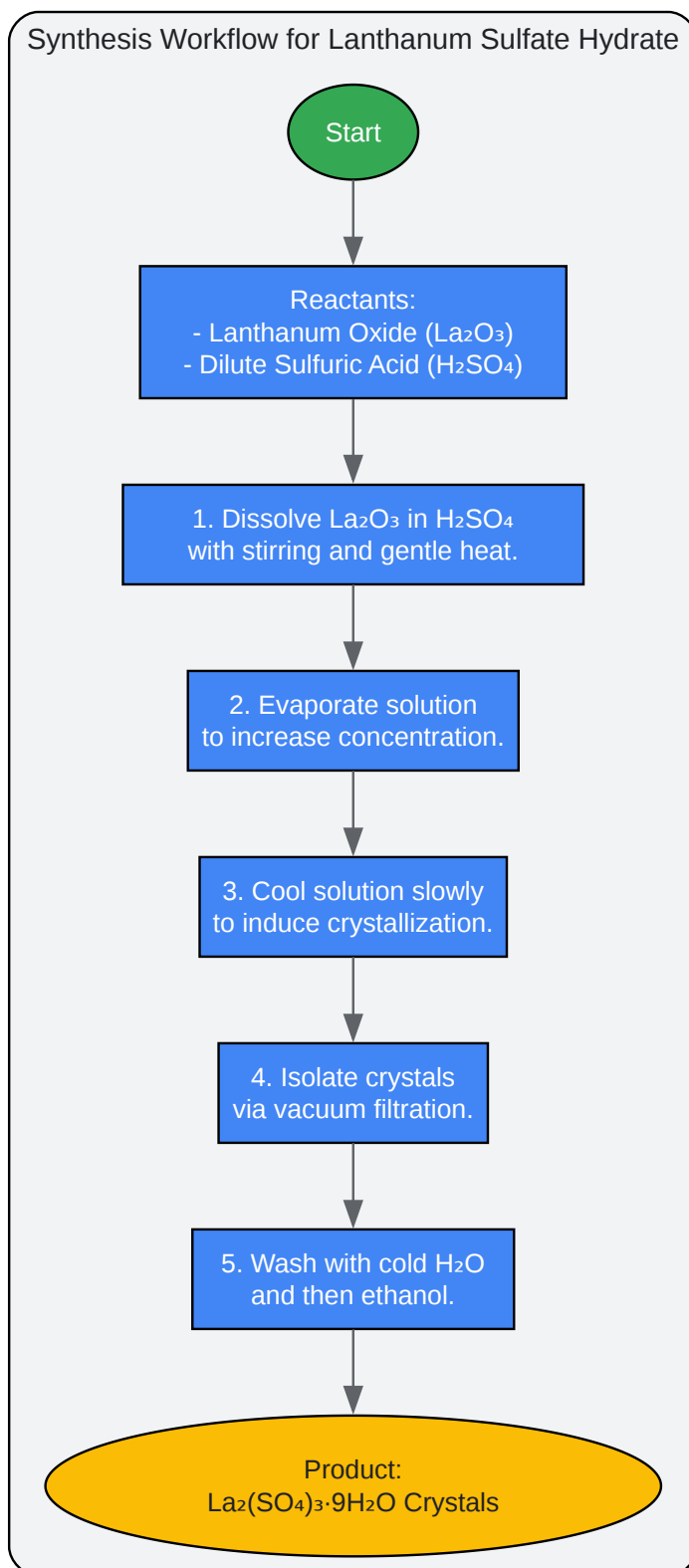

[Click to download full resolution via product page](#)

A workflow for the laboratory synthesis of **lanthanum sulfate**.

Characterization by Thermal Analysis

Thermogravimetric Analysis (TGA) and Differential Thermal Analysis (DTA) are used to study the thermal decomposition of **lanthanum sulfate** hydrates.

Methodology:

- A small, precisely weighed sample of $\text{La}_2(\text{SO}_4)_3 \cdot 9\text{H}_2\text{O}$ is placed in a crucible within the TGA/DTA instrument.
- The sample is heated at a constant rate (e.g., $10\text{ }^\circ\text{C}/\text{min}$) under a controlled atmosphere (e.g., air or nitrogen).
- The TGA instrument records the change in mass as a function of temperature, revealing the loss of water and sulfur oxides.
- The DTA instrument records the difference in temperature between the sample and a reference, identifying endothermic and exothermic events corresponding to dehydration and decomposition.[9]

Quantitative Analysis by Complexometric Titration

The concentration of lanthanum in a solution can be determined by titration with ethylenediaminetetraacetic acid (EDTA).

Methodology:

- **Sample Preparation:** An accurately measured volume of the lanthanum-containing sample is placed in a beaker and diluted with deionized water.
- **Buffering:** A buffer solution (e.g., urotropine) is added to adjust and maintain the pH of the solution between 5 and 6.[16]
- **Indicator:** A suitable colorimetric indicator, such as Xylene Orange or Eriochrome Black T, is added to the solution.[16]
- **Titration:** The solution is titrated with a standardized 0.1 M EDTA solution. The EDTA forms a stable complex with the La^{3+} ions.

- Endpoint Detection: The endpoint is reached when all La^{3+} ions have been complexed by the EDTA, indicated by a distinct color change of the indicator. An optical sensor can be used for precise endpoint detection.[16] The concentration of lanthanum is calculated from the volume of EDTA used.

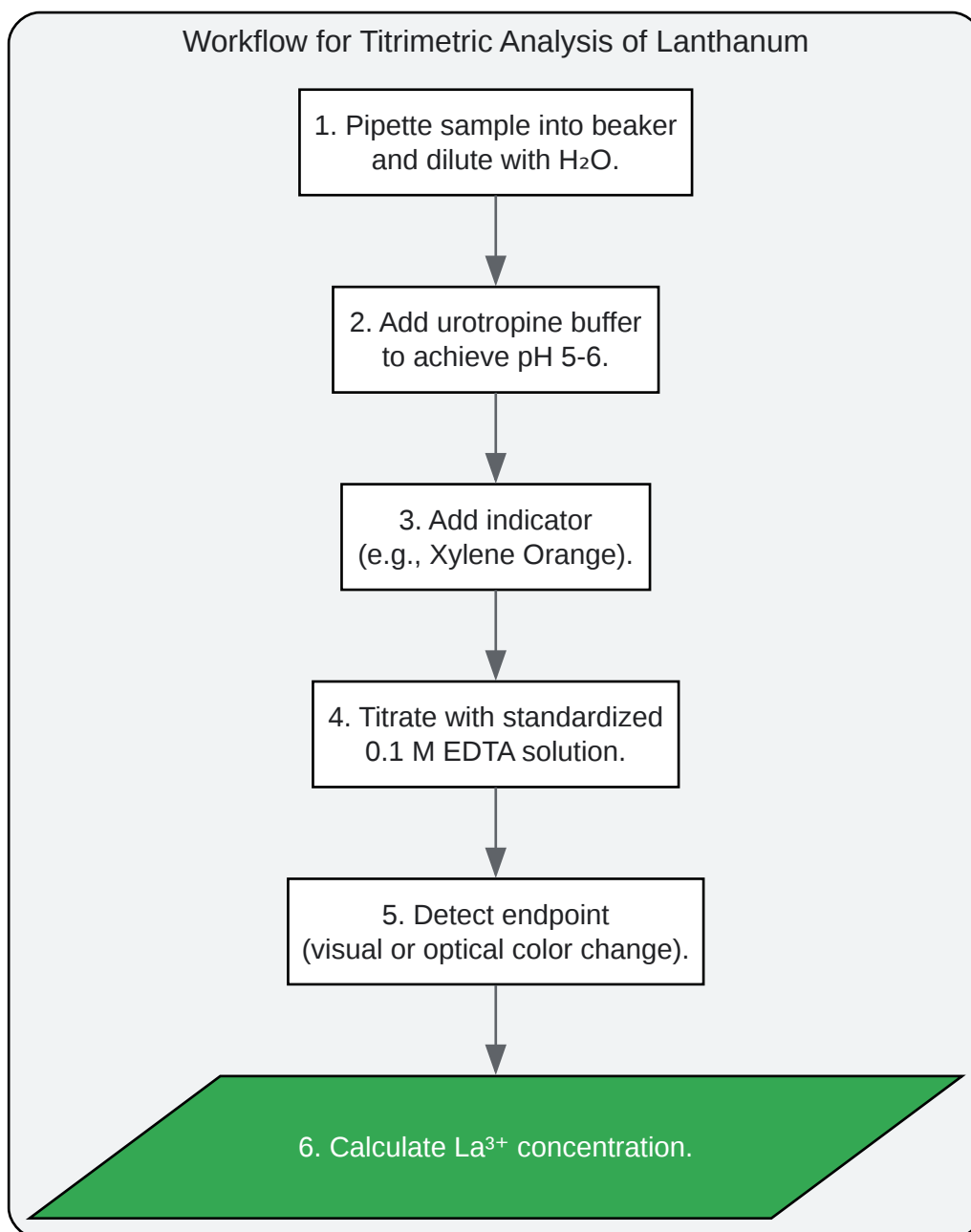

[Click to download full resolution via product page](#)

A logical workflow for the quantitative analysis of lanthanum.

Need Custom Synthesis?

BenchChem offers custom synthesis for rare earth carbides and specific isotopic labeling.

Email: info@benchchem.com or [Request Quote Online](#).

References

- 1. Lanthanum(III) sulfate - Wikipedia [en.wikipedia.org]
- 2. americanelements.com [americanelements.com]
- 3. nbinno.com [nbinno.com]
- 4. jameasaifiyah.edu [jameasaifiyah.edu]
- 5. chemimpex.com [chemimpex.com]
- 6. Lanthanum sulfate | La₂O₁₂S₃ | CID 159259 - PubChem [pubchem.ncbi.nlm.nih.gov]
- 7. Lanthanum Sulfate La₂(SO₄)₃.xH₂O Supplier [attelements.com]
- 8. lanthanum sulfate [chemister.ru]
- 9. researchgate.net [researchgate.net]
- 10. researchgate.net [researchgate.net]
- 11. Thermal decomposition of the rare earth sulfates of cerium(III), cerium(IV), lanthanum(III) and samarium(III) (Journal Article) | OSTI.GOV [osti.gov]
- 12. mdpi.com [mdpi.com]
- 13. researchgate.net [researchgate.net]
- 14. webelements.com [webelements.com]
- 15. researchgate.net [researchgate.net]
- 16. ysi.com [ysi.com]
- To cite this document: BenchChem. [A Technical Guide to the Physical and Chemical Properties of Lanthanum Sulfate]. BenchChem, [2025]. [Online PDF]. Available at: [https://www.benchchem.com/product/b162627#physical-and-chemical-properties-of-lanthanum-sulfate]

Disclaimer & Data Validity:

The information provided in this document is for Research Use Only (RUO) and is strictly not intended for diagnostic or therapeutic procedures. While BenchChem strives to provide accurate protocols, we make no warranties, express or implied, regarding the fitness of this product for every specific experimental setup.

Technical Support: The protocols provided are for reference purposes. Unsure if this reagent suits your experiment? [[Contact our Ph.D. Support Team for a compatibility check](#)]

Need Industrial/Bulk Grade? [Request Custom Synthesis Quote](#)

BenchChem

Our mission is to be the trusted global source of essential and advanced chemicals, empowering scientists and researchers to drive progress in science and industry.

Contact

Address: 3281 E Guasti Rd
Ontario, CA 91761, United States
Phone: (601) 213-4426
Email: info@benchchem.com